

LOFTNESS

Since 1956

650 South Main Street - Hector, Minnesota 55342 USA
320-848-6266 or 800-828-7624 - loftness.com - info@loftness.com

Effective Date
February 1, 2010

2010 RETAIL PRICES

Subject to Change - USD
FOB Factory - Uncrated

20-30 ton Excavator-mounted Carbide Cutter Extreme



Factory approved applications only. Call

NEW!

FORESTRY MULCHING HEADS for Excavators

Standard Features & Specifications

For Use on 20-30 Ton Excavators

Factory approved applications only. Please Call

- Voac Bent-axis Piston Motors
- Premium Strength Steel Housing
- Machined Bearing Anti-wrap Design
- 6-Groove Banded Belt
- Adjustable Re-cutter Bar at Discharge
- Skid Shoes
- Hitch Transferable to Multiple Positions
- Rotor Speed 1300 to 1800 rpm
- Efficient Spiral Carbide Tooth Pattern
- Charcoal Grey Paint
- Heavy-duty Overhung Bearing Block
- 100-150 Hydraulic Horsepower Required
- Steel Deflector Chains
- Spring-loaded Belt Tightener
- Taper-lock Sheaves
- Two Stage Cutting Chamber
- 21 inch Diameter Rotor
- 3 inch Piloted Double Taper Roller Bearings
- Carbide Teeth with Forged Steel Holders
- Optional Planer Carbide Teeth



2010 RETAIL PRICES

Effective Date
February 1, 2010

Subject to Change - USD FOB Factory - Uncrated



20-30 ton Excavator- mounted Carbide Cutter Extreme

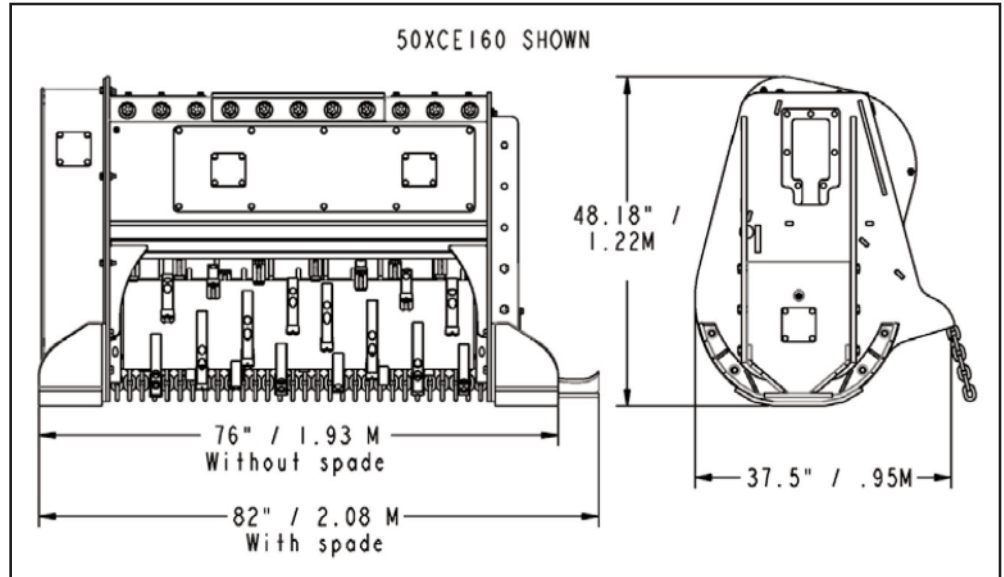

Specifications

Width of Cut
Overall Width
Overall Width with Spade
Number of Carbides
Weight

40XCE160

40" / 1.01 M
66" / 1.68 M
72" / 1.83 M
24
3250 lbs/1475 kg

50XCE160

50" / 1.27 M
76" / 1.93 M
82" / 2.08 M
30
3900 lbs/1769 kg

60XCE160

60" / 1.53 M
86" / 2.19 M
92" / 2.34 M
36
4550 lbs/2064 kg

Prices

Standard Carbides
List Price

40XCE160S
\$ 46,758.00

50XCE160S
\$ 48,198.00

60XCE160S
\$ 49,538.00

Planer Carbides
List Price

40XCE160P
\$ 46,998.00

50XCE160P
\$ 48,498.00

60XCE160P
\$ 49,998.00

Options

Set of Replacement
Standard Carbides

N25142
\$ 1,560.00

N25143
\$ 1,950.00

N25144
\$ 2,340.00

Set of Replacement
Planer Carbides

N25146
\$ 1,800.00

N25147
\$ 2,250.00

N25148
\$ 2,700.00

2nd Shear Bar

N24140
\$ 750.00

N21469
\$ 800.00

N24141
\$ 850.00

End Spade with Hook

N21491
\$ 360.00

N21491
\$ 360.00

N21491
\$ 360.00

Please Note: The Planer teeth, with their surface-mounted carbides and sharper cutting edges, are more susceptible to damage and are NOT recommended for rocky conditions.

Visit our Carbide Cutter web site. www.carbide-cutter.com



e-mail: info@loftness.com - Fax: 320-848-6269

650 South Main Street - Hector, MN 55342 USA