



Since 1956

650 South Main Street - Hector, Minnesota 55342 USA
320-848-6266 or 800-828-7624 - loftness.com - info@loftness.com

Effective Date
February 1, 2010
N14505

2010 RETAIL PRICES

Subject to Change - USD
FOB Factory - Uncrated

Front-mounted Flail Mowers for Skid-steers

Mowers work with as little as 10 GPM!

Note: 20+ GPM is recommended for tall weeds and intermittent brush.



60, 72 & 90 inch

Cut grass and weeds, or up to one inch diameter brush intermittently.



Charcoal Grey Paint

Heat-treated, Reversible, Side-slice, Fine-cut Knives

Standard Features

- * NEW Hoses are included (couplers are not).
- * Heavy-duty, Bearing Block
- * 3-B Section Banded Belt
- * 0 - 4 1/2 inch Cutting Height (roller adjustment)
- * Easy Access Belt Shield
- * 1/4 inch End Plates
- * 5 1/2" OD x 1/4" Wall Roller Tube
- * 10 Gauge Hood
- * Structural Steel Frame, Front & Rear
- * Standard High-efficiency Gear-type Motor
- * Spring-loaded Belt Tightener
- * Full-width Gauge Roller with Roller Scraper
- * Fine-cut, Reversible Knives
- * 1 3/4 inch Rotor Bearings
- * 2190 RPM Rotor Speed
- * 1 1/2 inch Bearing on Gauge Roller

Specifications

Cutting Width
Overall Width
Number of Knives
Weight
Crated Weight

Please Note: Most new models now require a case drain line to be attached to your skid-steer.

	60 MH	72 MH	90 MH
Cutting Width	60 inches	72 inches	90 inches
Overall Width	72 inches	84 inches	102 inches
Number of Knives	80	96	120
Weight	930 pounds	1,008 pounds	1,208 pounds
Crated Weight	1,225 pounds	1,275 pounds	1,475 pounds

Model Selections below 3500 PSI

10-12 gpm, 3000-3500 psi	60 MH 1		
13-16 gpm, 2500-3500 psi	60 MH 2	72 MH 2	
17-20 gpm, 2000-3500 psi	60 MH 3	72 MH 3	
21-24 gpm, 2000-3500 psi	60 MH 4	72 MH 4	90 MH 4
25-28 gpm, 2000-3500 psi*	60 MH 5	72 MH 5	90 MH 5
29-32 gpm, 2000-3500 psi*	60 MH 6	72 MH 6	90 MH 6
33-37 gpm, 2000-3500 psi*	60 MH 7	72 MH 7	90 MH 7
38-42 gpm, 2000-3500 psi*	60 MH 8	72 MH 8	90 MH 8
List Price * case drain required	\$ 7,960.00	\$ 8,320.00	\$ 8,820.00
Crating Price (net)	\$ 95.00	\$ 105.00	\$ 135.00

48, 60, 72 & 90 inch Flail Mowers for Tractors

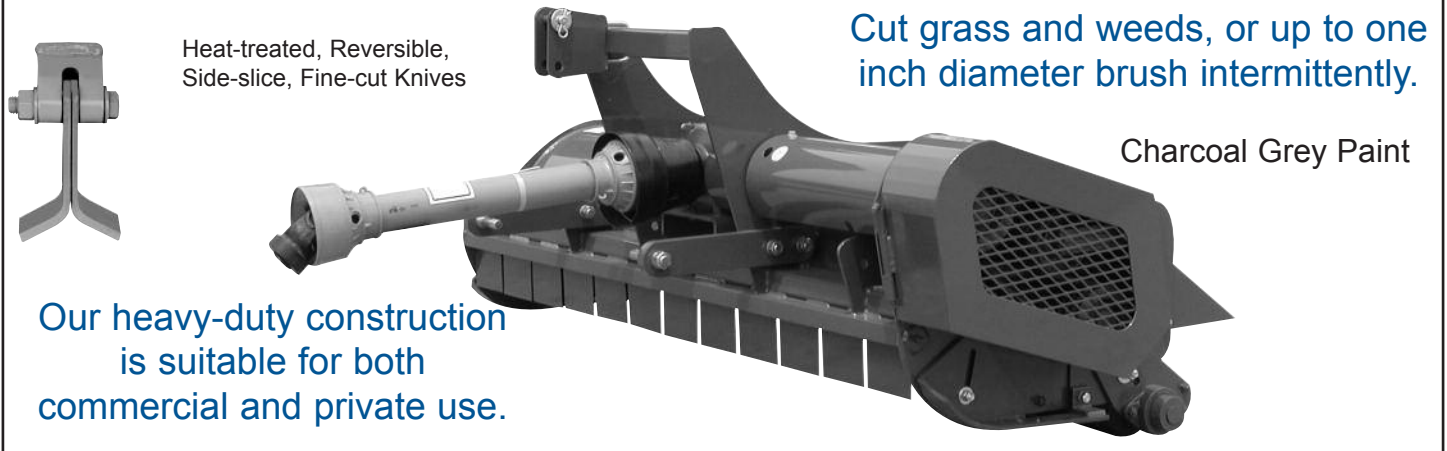

Standard Features

- * 70 HP Gearbox & Driveline
- * 540 RPM PTO shaft
- * Cat. I or II, Free-link or Quick Hitch
- * 3-B Section Banded Belt
- * Spring-loaded Belt Tightener
- * 1 3/4 inch Rotor Bearings
- * 10 Gauge Hood
- * 1/4 inch End Plates
- * Structural Steel Frame, Front & Rear
- * 0 - 4 1/2 inch Cutting Height Adjustment
- * Fine-cut, Reversible Knives
- * Easy Access Belt Shields
- * 2190 RPM Rotor Speed
- * Full-width Gauge Roller
- * 5 1/2 inch OD x 1/4 inch Wall Roller Tube
- * 1 1/2 inch Bearing on Gauge Roller
- * Roller Scraper
- * Centered or 14 inches Offset to the Right

Specifications & Prices

Model	48M	60M	72M	90M
Width	48 inches	60 inches	72 inches	90 inches
HP required	14	16	20	25
Number of Knives	64	80	96	120
Rotor Tube	4 1/2" OD, 5/16" wall	4 1/2" OD, 5/16" wall	4 1/2" OD, 5/16" wall	5 1/2" OD, 5/16" wall
Tip Speed	104 MPH	104 MPH	104 MPH	110 MPH
Weight	750 pounds	900 pounds	1,040 pounds	1,200 pounds
Crated Weight	855 pounds	1,035 pounds	1,255 pounds	1,430 pounds
List Price	\$ 5,270.00	\$ 5,580.00	\$ 5,920.00	\$ 6,420.00
Optional flexible chain lift for tractor three-point allows mower to float. P/N N11913				\$ 110.00
Crating Price (net) \$	85.00	95.00	105.00	135.00

Visit our Flail Mower web site. www.flailmower.com