



Stump Ax

Stump Grinder

24 • 31

Owner's Manual and Parts Book
(24" Originating w/Serial Number 109-123)
(31" Originating w/Serial Number 114-101)



Model Number: _____
Serial Number: _____
Date of Purchase: _____

LOFTNESS ™

LOFTNESS SPECIALIZED EQUIPMENT, INC.

LIMITED WARRANTY POLICY

The limited warranty policy begins upon delivery of the unit to the original customers.

The following Loftness products have a two (2) year limited warranty;

XLB10 Grain Bag Loader, Battle Ax L-series Skid Steer, Battle Ax S-series Skid Steer, Battle Ax H-series Skid Steer, Battle Ax Excavator 20-series, Battle Ax Excavator 30-series, Battle Ax Excavator 40-series, Battle Ax Excavator 50-series, Battle Ax Extreme, Bad Ax Skid Steer, Timber Ax Skid Steer, Stump Ax, BT20, Kwik Cut.

All other Loftness products have a one (1) year limited warranty.

If any Loftness product is used as rental or leased equipment the limited warranty period is for only 30 days from the delivery date to the original customers.

Loftness Specialized Equipment, hereinafter referred to as LOFTNESS, a manufacturer of quality machinery since 1956, warrants new LOFTNESS machinery and/or attachments at the time of delivery to the original purchaser, to be free from defects in material and workmanship when properly set up and operated in accordance with the recommendations set forth in the LOFTNESS Operator's Manual.

LOFTNESS' liability for any defect with respect to accepted goods shall be limited to repairing the goods at an authorized dealer or other LOFTNESS designated location, or replacing them as LOFTNESS shall elect. The above shall be in accordance with LOFTNESS warranty adjustment policies.

WARRANTY REQUIREMENTS

Warranty registration form must be filled out and returned to Loftness Specialized Equipment to validate all warranty claims.

To receive a warranty claim, a return authorization from LOFTNESS must be obtained. The failed part may then be returned in an untampered status. This warranty does not include freight or delivery charges incurred when returning machinery for servicing. Dealer mileage, service calls and pick-up/delivery charges are the customer's responsibility.

LIMITATIONS OF WARRANTY

LOFTNESS products are designed to provide years of dependable service when proper use and maintenance is adhered to. The potential for misuse in many applications exists; therefore, a limited warranty is provided as follows.

This warranty shall not apply to any machine or attachment which shall have been repaired or altered outside the LOFTNESS factory or authorized LOFTNESS dealership or in any way so as in LOFTNESS' judgment, to affect its stability or reliability, nor which has been subject to misuse, negligence or accident, nor to any machine or attachment which shall not have been operated in accordance with LOFTNESS' printed instructions or beyond the company recommended machine rated capacity. LOFTNESS may elect to have an area representative evaluate the condition of the machine before warranty is considered.

In addition, this limited warranty provides no coverage for general wear or maintenance items, misuse, environmental conditions and/or contamination for which they were not designed or not intended, including but not limited to the following items;

Use of machine beyond its rated capacity, Conveyors, Improper knife replacement, Auger wear, Missing knives, Saw blades, Striking foreign objects, Brakes and brake pads, Lack of lubrication, Tires, Failures caused by running in an "out-of-balance" condition, Hydraulic hoses damaged by being caught in "pinch points" or by moving parts, and Damage caused by excessive force from the power unit.

EXCLUSIONS OF WARRANTY

Except as otherwise expressly stated herein, LOFTNESS makes no representation or warranty of any kind, expressed or implied. **The implied warranty of merchantability and fitness for a particular purpose are excluded from this limited warranty.** The remedies set forth in this warranty are the only remedies available to any person under this warranty. LOFTNESS shall have no liability to any person for incidental, consequential or special damages of any description, whether arising out of express or implied warranty or any other contract, negligence, or other tort or otherwise. This exclusion of consequential, incidental and special damages is independent from and shall survive any finding that the exclusive remedy failed of its essential purpose. Upon purchase, the buyer assumes all liability, all personal injury and property damage resulting from the handling, possession or use of the goods by the buyer.

No agent, employee or representative of LOFTNESS has any authority to bind LOFTNESS to any affirmation, representation or warranty concerning its machinery and/or attachments except as specifically set forth herein. (August 2023)

LOFTNESS ™

Table of Contents

Warranty

Table of Contents

Ordering Code

Ordering Code	1
Stump Ax (Example)	1

Introduction

Owner Information	3
Warranty Policy	3
Serial Number Location	3
Owner's Manual Access	3
Stump Ax Features	4

Safety Instructions

Safety First	5
Owner's Responsibility	5
Mandatory Shut-Down Procedure	6
Safety Rules	6
Operating Safety	6
Maintenance Safety	7
Hydraulic Safety	8
California Proposition 65 Warning	8
Stump Ax Identification	9
Safety Decal Locations	10
Stump Ax 24"	10
Stump Ax 31"	11

Set-up Instructions

Attaching the Stump Ax to a Skid Loader	13
Hydraulic Connections	13
Attaching Stump Ax to an Excavator	14
Hydraulic Connections	14
Jack Stand (Skid Loader models)	15
Raising the Jack Stand	15
Lowering the Jack Stand (Storage)	15
Checking Wheel Rotation	15

Operating Instructions

Getting Started	17
Pre-start Checklist	17
For first-time users	17
General Operation and Cutting Instructions - Skid Loader models	18
Blade (Skid Loader models)	18
Stopping the Stump Ax	18
Detaching Stump Ax from the Skid Loader	18
Hose Storage (Skid Loader models)	19

Table of Contents

Operating Instructions (Cont'd)

General Cutting Instructions - Excavator models	19
Detaching Stump Ax from the Excavator	19
Transporting.	20
Road Travel	20
Hauling.	20

Maintenance

General Maintenance	21
Break-In Schedule.	21
Maintenance Schedule	21
Lubrication.	21
Changing Bearing Support Gear Lube	21
Removing the Motor Cover	22
Tooth Removal and Installation	22
Wheel Removal	23
Storage	23
End of Season	23
Beginning of the Season	23
GPM Chart.	24
110cc Instant Torque Radial Piston Motor - 24" Model	24
GPM Chart.	25
200cc Instant Torque Radial Piston Motor - 31" Model	25
Troubleshooting.	26

Parts Identification

Housing; Disc, Motor - 24" Model.	28
Housing; Disc, Motor - 31" Model.	29
Lubrication; Relief Manifold - 24" Model.	30
Lubrication; Relief Manifold - 31" Model.	31
Deflector Assembly - 24" Model	32
Deflector Assembly - 31" Model	33
Mount, Jack, Hydraulic Group	34
Hydraulic Group (212402) - 24" Model	36
Hydraulic Group (212417) - 31" Model	38
Wheel, 24 Phantom Stump Grind Leonardi (209966)	40
Wheel, 31 Phantom Stump Grind Leonardi (209433)	41
Kit, Tomahawk Grinder Teeth L/R Leonardi (209530)	42
Kit, Tomahawk Grinder Teeth 2/S Leonardi (209531)	42
Kit, Tomahawk Grinder Teeth 2/L Leonardi (209532)	43
Kit, Tomahawk Grinder Teeth 2/R Leonardi (209533)	43
SAI Motor (209967) - 24" Model	44
Seal, SAI Bearing Support Shaft (212129) - 24" Model	45
SAI Motor (209576) - 31" Model	46
Seal, SAI Bearing Support Shaft (212126) - 31" Model	47
Machine Decals and Signs	48

Table of Contents

Appendix

Specifications	51
Dimensions - 24" Stump Ax	52
Dimensions - 31" Stump Ax	53
Torque Specifications	54
Inches Hardware and Lock Nuts	54
Metric Hardware and Lock Nuts	55



Ordering Code

Stump Ax (Example)

The ordering code will consist of two numbers (machine size), two letters (machine type), one letter (operating style), one letter (wheel type) and one or more letters (options). An example for a Fixed Stump Grinder of this type would be as shown below.

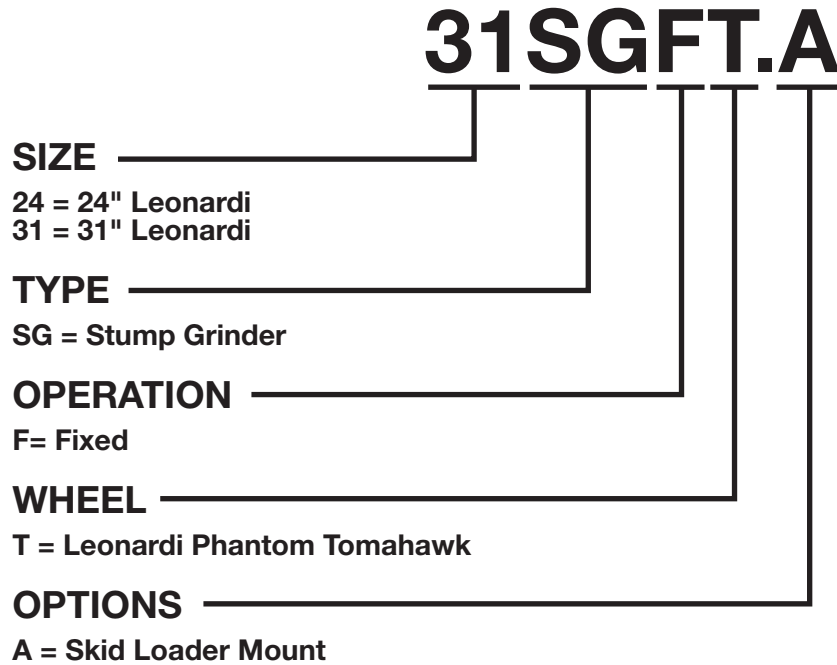



Owner Information

Thank you for your decision to purchase a Stump Ax from Loftness. To ensure maximum performance of your machine, it is mandatory that you thoroughly study the owner's manual and follow its recommendations. Proper operation and maintenance are essential to prevent injury or damage and to maximize machine life.

NOTE: *This manual provides safety instructions, setup, operation, and maintenance instructions for two stump grinder models - the Stump Ax 24" and the Stump Ax 31". The instructions and information provided apply to both models unless specified.*

Given the similarity between the two models, some images within the manual may portray one model, but will pertain to both. In some cases, a note will be placed in the image to help clarify which model is being shown.

The Loftness Stump Ax is an effective, reliable machine used for grinding and clearing both freshly cut or aged tree stumps. Machine options allow for the Stump Ax to be powered by either a skid loader or excavator with a 30-60 GPM hydraulic flow rating. Tipped with 48 carbide teeth, the hardened steel wheel has cut-outs to create a see-through effect for improved visibility, giving operators a clear and safer view of the cutting action.

Operate and maintain this machine in a safe manner and in accordance with all applicable local, state, and federal codes, regulations and/or laws, and in compliance with on-product labeling and these instructions.

Make sure that all personnel have read this owner's manual and thoroughly understand safe and correct operating, installation and maintenance procedures.

Continuous improvement and advancement of Loftness products may result in changes to your equipment that may not be reflected in this publication. Loftness reserves the right to make product improvements to the machine at any time. Although great care has been taken to ensure the accuracy of this publication, Loftness does not assume any liability for errors or omissions.

Warranty Policy

Be sure to read and understand the Warranty Policy at the beginning of this manual. It is also important that you fill out the Warranty Registration form(s) completely with your dealer so as not to void the warranty.

Serial Number Location

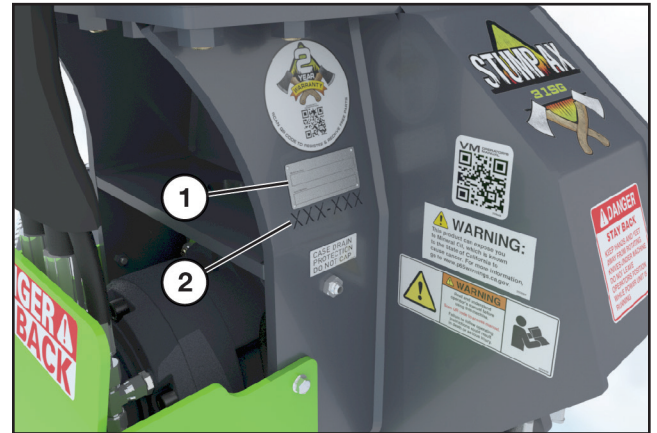

The machine serial number is shown in the tag (1), and is also stamped into the machine frame (2) below the serial number tag.

Always use your model and serial number when requesting information or when ordering parts.

Owner's Manual Access



The Stump Ax is shipped with a printed owner's manual. The manual must be available for all operators. Keep in a safe, dry location.

To access a digital owner's manual, use a smart phone to scan the QR Code (1) located on the front left side of the wheel housing. This code will link to the Stump Ax owner's manual on the Loftness website.

Introduction

Stump Ax Features

24" Model

- 110cc Instant Torque Radial Piston Motor
- 17-35.9 GPM at 5000 PSI
- 30-80 Hydraulic Horsepower Required
- 24 in. Diameter Wheel
- No Welding on Wheel - Fully Machined
- 30 Teeth
- Bolt-on Replaceable Tooth Mounts
- Premium Strength Steel Body & Disc
- Controlled Discharge Deflector Chains
- Anti-cavitation Shut Down Circuit
- Universal Skid-Steer Mount
- Hoses Included on Skid Loader Model (couplers not included)

31" Model

- 200cc Instant Torque Radial Piston Motor
- 30-60 GPM at 5000 PSI
- 60-120 Hydraulic Horsepower Required
- 31 in. Diameter Wheel
- No Welding on Wheel - Fully Machined
- 48 Teeth
- Bolt-on Replaceable Tooth Mounts
- Premium Strength Steel Body & Disc
- Controlled Discharge Deflector Chains
- Anti-cavitation Shut Down Circuit
- Universal Skid-Steer Mount
- Hoses Included on Skid Loader Model (couplers not included)

Safety First

	Safety Alert Symbol
<p>This message alert symbol identifies important safety messages on the machine and in the owner's manual. When you see this symbol, be alert to the possibility of personal injury and carefully read the message that follows.</p>	

In the owner's manual and on decals used on the machine the words **DANGER, WARNING, CAUTION, IMPORTANT, and NOTE** are used to indicate the following:

DANGER: This word warns of immediate hazards which, if not avoided, will result in severe personal injury or death. The color associated with Danger is RED.



WARNING: This word refers to a potentially hazardous situation which, if not avoided, could result in severe personal injury or death. The color associated with Warning is ORANGE.

CAUTION: This word refers to a potentially hazardous or unsafe situation that, if not avoided, may result in minor or moderate injury. It may also be used to alert against unsafe practices. The color associated with Caution is YELLOW.

IMPORTANT: Highlights information that must be heeded.

NOTE: A reminder of other related information that needs to be considered.

If Safety Decals on this machine are ISO two panel pictorial, decals are defined as follows:

- The first panel indicates the nature of the hazard.
- The second panel indicates the appropriate avoidance of the hazard.
- Background color is YELLOW.
- Prohibition symbols such as  and  if used, are RED.

Be certain all machine operators are aware of the dangers indicated by safety decals applied to the machine, and be certain they follow all safety decal instructions. Contact Loftness for safety decal replacement.

Loftness cannot anticipate every possible circumstance that may involve a potential hazard. The warnings in this owner's manual are not all inclusive.

Owner's Responsibility

Due to the potential danger of flying debris, it is the owner's responsibility and is **ABSOLUTELY MANDATORY** that **IMPACT-RESISTANT SHIELDING** be installed on the machine to protect the operator.

It is **ABSOLUTELY MANDATORY** that all personnel read and follow all safety precautions before operating the machine and attachment.

Make sure that all personnel have read this owner's manual, and thoroughly understand safe and correct installation, operation, and maintenance procedures.

Operate and maintain this machine in a safe manner and in accordance with all applicable local, state, and federal codes, regulations and/or laws; and in compliance with on-product labeling and this owner's manual instructions.

Make sure that all personnel know how to stop the machine and attachment by disengaging all controls. See "Mandatory Shut-Down Procedure" on page 6.

Make sure the attachment is installed on the machine correctly before being placed in service. At regular intervals thereafter, the attachment should be serviced in accordance with procedures outlined in this owner's manual.

Do not use the Stump Ax for anything other than grinding tree stumps. Severe damage could result if it is used for any application other than grinding stumps.

Safety Instructions

Mandatory Shut-Down Procedure

- Stop the power unit with attachment on a level surface, and disengage all power to the attachment. Lower the attachment to the ground.
- Move throttle to idle position.
- Shut off engine and remove the key.

Wait until the impeller has stopped completely before inspecting the attachment.

Safety Rules

These are general safety considerations. Additional precautions may be necessary to operate your machine in a safe manner. Be certain you are operating your machine in accordance with all safety codes, OSHA rules and regulations, insurance requirements and local, state, and federal laws.

Operating Safety

- Do not use the Stump Ax for anything other than grinding tree stumps. Severe damage could result if it is used for any application other than grinding stumps.
- Do not start, operate, or work on this attachment until you have carefully read and thoroughly understand the contents of this manual and the operator's manual for your power unit.
- Read and observe all warnings decals on the machine before attempting to operate the attachment. Do not attempt to operate this attachment unless all factory devices and decals are in place. Keep safety decals clean of dirt and grime. Keep all guards, shields and decals in place.
- Become familiar with and know how to operate all safety devices and controls on the machine and attachment before attempting to operate. Know how to stop the machine and attachment before starting it.
- Do not allow anyone to operate the attachment until he or she has read the owner's manual and is completely familiar with all safety precautions and controls. Keep the work area clear of all unauthorized personnel.
- Because of the potential safety hazard to eyes from flying debris, use of protective eyewear is absolutely mandatory for operator and others in the work area.
- Do not wear loose hanging clothes, neckties or jewelry around rotating parts. Long hair is to be placed under a cap or hat. These precautions will help prevent you from becoming caught in any moving parts on the machine and attachment.
- Do wear safety glasses, ear protection, respirators, gloves, hard hats, safety shoes and other protective clothing when required.
- Do not allow persons under the influence of alcohol, medications, or other drugs that can impair judgment or cause drowsiness to operate or maintain the machine.
- Never allow children to operate the equipment.
- Keep bystanders away from the Stump Ax while it is in operation, whether it is moving or idling.
- Keep children, bystanders and other workers off and away from the machine and attachment during operation. No riders allowed.
- Use the handholds and step plates when getting on and off the machine to prevent falls. Keep steps and platform cleared of mud and debris.
- Always have an operator in the machine while the attachment is in operation. Never leave the machine and attachment running and unattended.
- Keep your feet on the pedals, (floor plates) seat belt fastened snugly and seat bar lowered, (if equipped), when operating the attachment.
- Make certain there are no underground utilities or pipelines in the area where the Stump Ax will be operated. If you are not sure, contact your local utilities so they can mark the area. If underground utilities or pipeline are buried in the area of operation it is important to ask how close to the locator markers the Stump Ax can be operated.
- Always use an approved roll bar and seat belt for safe operation. Overturning a machine without a roll bar and seat belt can result in injury or death.
- Operate the attachment only from the operator's seat.

Safety Rules (Cont'd)

Operating Safety (Cont'd)

- Do not operate this machine above 60 GPM. Excessive speed can be dangerous and could cause personal injury or damage to your power unit or Stump Ax.
- Before leaving the operator's position for ANY reason or allowing anyone to approach the machine and attachment, always perform the mandatory shutdown procedure.
- Keep hands and feet clear! Never step over or climb over the attachment while the engine is running; entanglement could occur.
- Disengage auxiliary hydraulics and place all machine controls in neutral and engage the parking brake before starting the engine.
- Remove from area of operation all foreign objects such as bottles, rocks, wire, etc. that might become tangled in the wheel, causing damage to the machine or be thrown striking other objects.
- Repeated impact of the teeth with hard objects can cause excessive wear and damage to the power unit or attachment. Be sure to maintain recommended ground clearance as specified in this manual.
- Never attempt to make any adjustments while the attachment is running or the key is in the "ON" position in the machine. Before leaving the operator's position, disengage power to the attachment, shut off engine and remove ignition key.
- Should excessive vibration occur, disengage the hydraulics to the attachment and shut off engine. Do not continue to operate the attachment until the problem has been determined and corrected.

Maintenance Safety

- Do not work on this attachment until you have carefully read and thoroughly understand the contents of this manual and the operator's manual for your power unit.
- Before inspecting, cleaning, lubricating, adjusting or servicing any part of the attachment, always exercise the Mandatory Shut-Down Procedure. See "Mandatory Shut-Down Procedure" on page 6. After service has been performed, be sure to restore all guards, shields and covers to their original position.
- Never attempt to lubricate, or make any adjustments while the power unit or attachment is running, or the key is in the "ON" position in the machine. Before leaving the operator's position, disengage power to the attachment, shut off engine and remove ignition key.
- When performing any maintenance, make sure the area is clear of any distracting objects. Keep work areas clean and free of grease and oil to avoid slipping or falling.
- Before working under the attachment, be certain it is securely blocked!
- Do not smoke while servicing the machine.
- Do not touch the power unit or any attachment parts which might be hot from operation. Allow such parts to cool before attempting to maintain, adjust or service.
- Make sure all controls, (levers, pedals and switches), are in NEUTRAL position before starting the engine.
- Before leaving the operator's position for ANY reason or allowing anyone to approach the machine and attachment, always perform the mandatory shutdown procedure.
- Periodically check all guards, shields and structural members. Replace or repair anything that could cause a potential hazard.
- Do not replace components or parts with other than factory-recommended service parts. To do so may decrease the effectiveness of the machine and/or void the warranty.

Safety Instructions

Safety Rules (Cont'd)

Maintenance Safety (Cont'd)

- It is the operator's responsibility to be aware of machine and attachment operation and work area hazards at all times.
- Never operate the attachment without adequate light and visibility.
- Keep hands and feet clear! Never step over or climb over the attachment while the power unit is running; entanglement could occur.
- Operators are responsible to know the location and function of all guards and shields. Operators are responsible to make certain that all guards are in place when operating the machine and attachment.
- Operators are responsible to be aware of safety hazard areas and follow instructions on warning, caution, or danger decals applied to the machine.
- Know the area before operating the machine. Be aware of underground utility lines, dwellings, and other equipment.

Hydraulic Safety

	WARNING: <i>Contact with high pressure fluids may cause fluid penetration and burn hazards. Fluid that is under pressure can penetrate body tissue. Fluid penetration can cause serious injury and possible death. If fluid is injected into the skin, seek medical attention immediately!</i>
---	---

- Always wear safety goggles or glasses when working on hydraulic system to avoid eye injury.
- The hydraulic system is under high pressure. Make sure all lines and fittings are tight and in good condition. These fluids escaping under high pressure can have sufficient force to penetrate skin and cause serious injury.
- Never check for leaks by using any part of your body to feel for escaping fluid.
- To prevent serious personal injury from escaping high pressure fluid, never attempt to inspect, service or disassemble any part of the hydraulic system until all pressure has been relieved from the system.

California Proposition 65 Warning

	WARNING: <i>This product can expose you to Mineral Oil, which is known to the State of California to cause cancer. For more information, go to www.p65warnings.ca.gov.</i>
---	---

A decal with this warning statement is adhered to the machine. If the decal should become worn or missing, replace immediately.

Stump Ax Identification

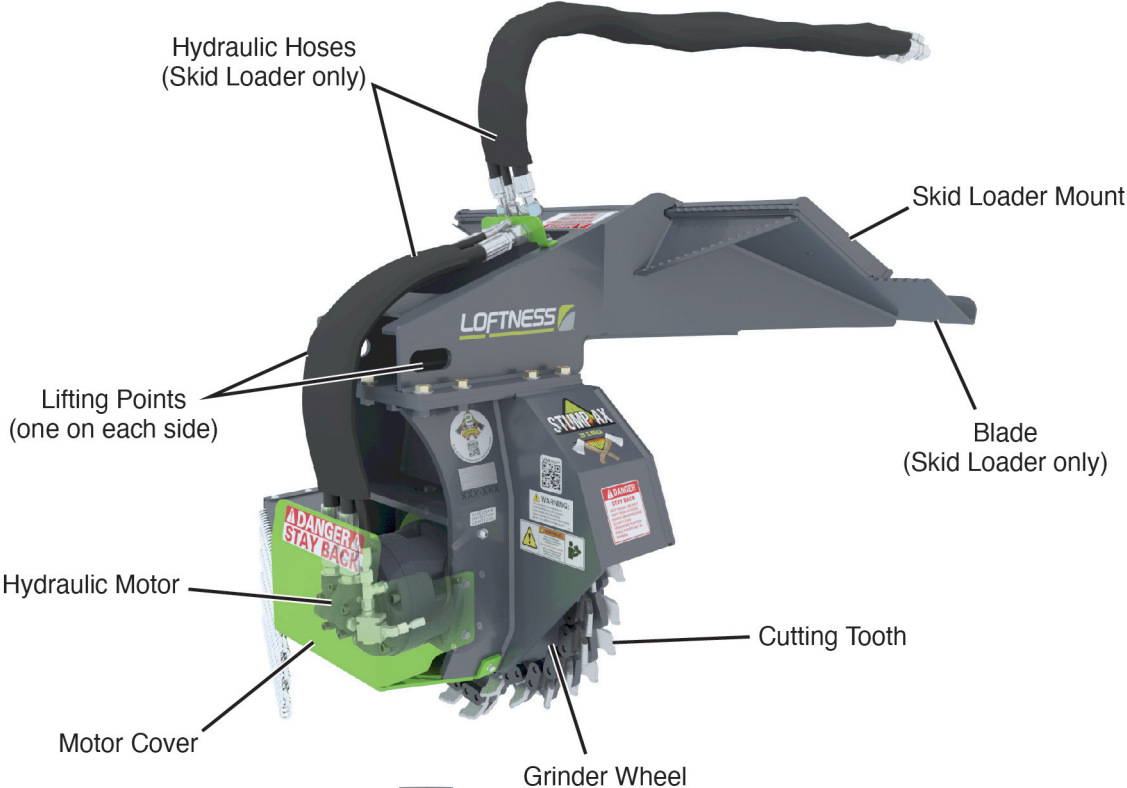

NOTE: 31 in. Stump Ax model shown.

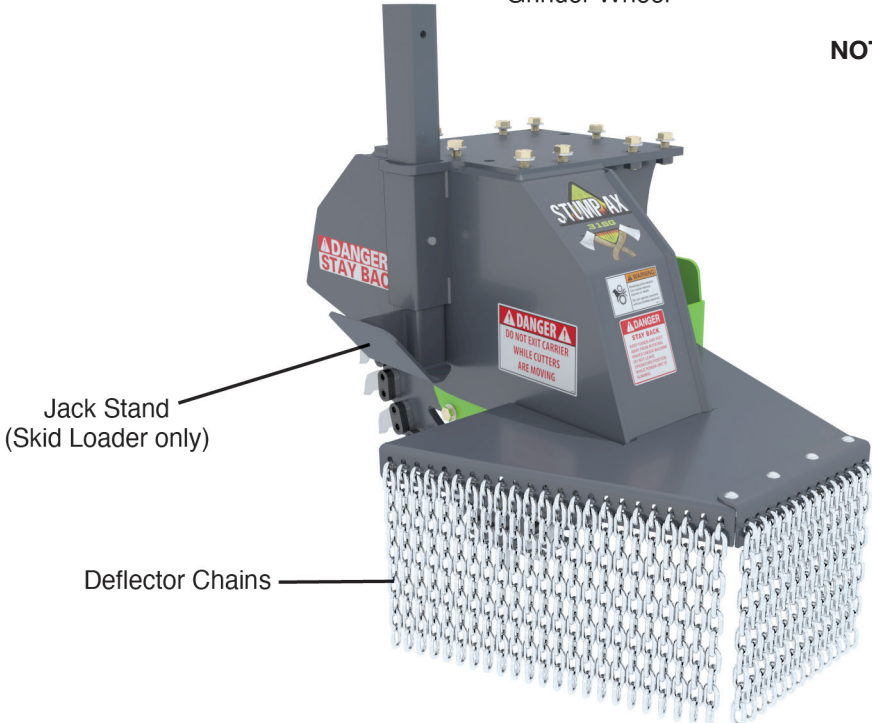

Safety Instructions

Safety Decal Locations

Stump Ax 24"

Check and replace any worn, torn, hard to read or missing safety decals on your machine.

NOTE: This section shows where safety-related decals are applied on the machine. For all machine decals see "Machine Decals and Signs" on page 48.

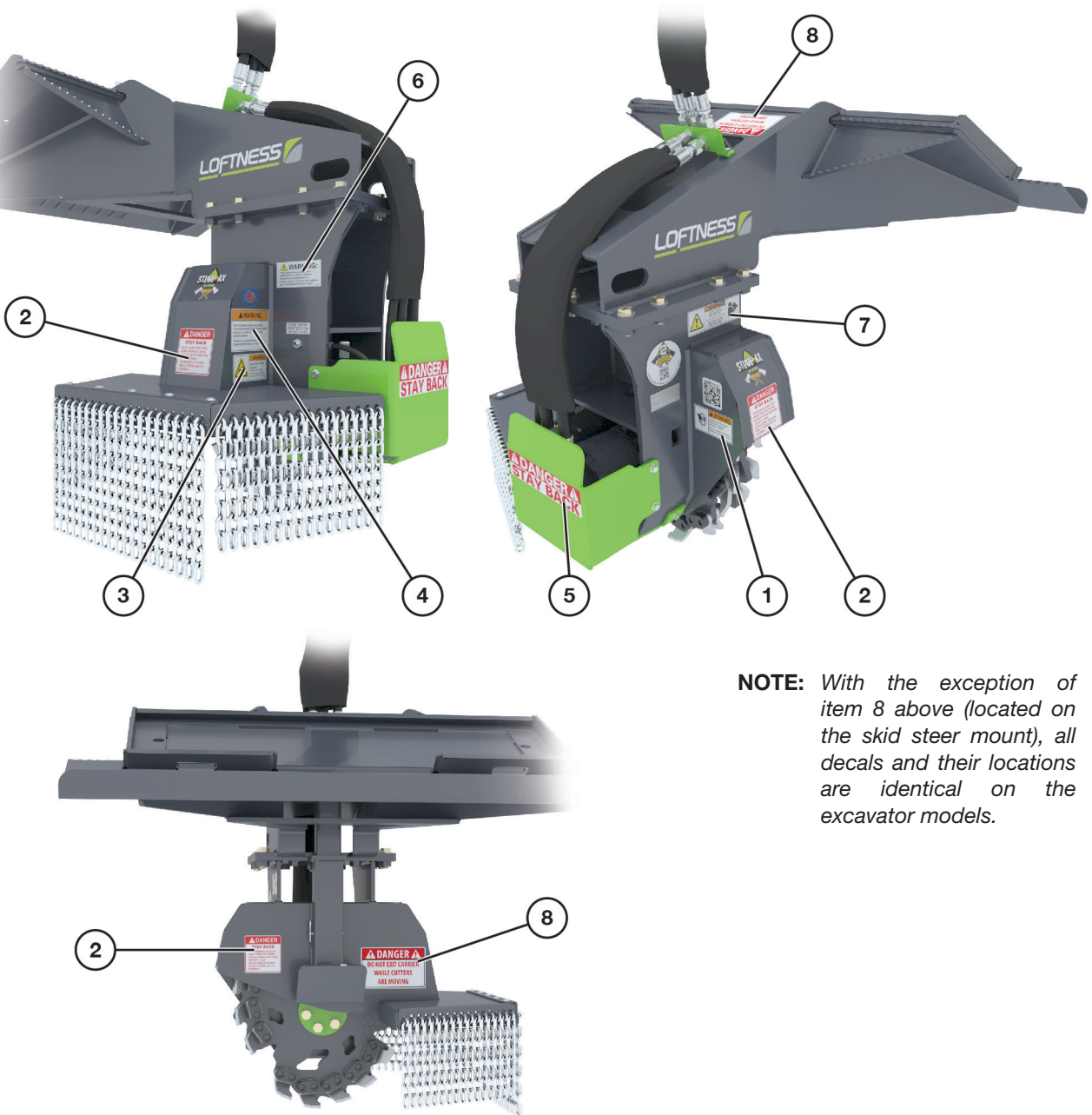

NOTE: With the exception of item 8 above (located on the skid steer mount), all decals and their locations are identical on the excavator models.

See page 12 for detailed images of the safety decals called out above.

Safety Decal Locations

Stump Ax 31"

Check and replace any worn, torn, hard to read or missing safety decals on your machine.

NOTE: This section shows where safety-related decals are applied on the machine. For all machine decals see "Machine Decals and Signs" on page 48.

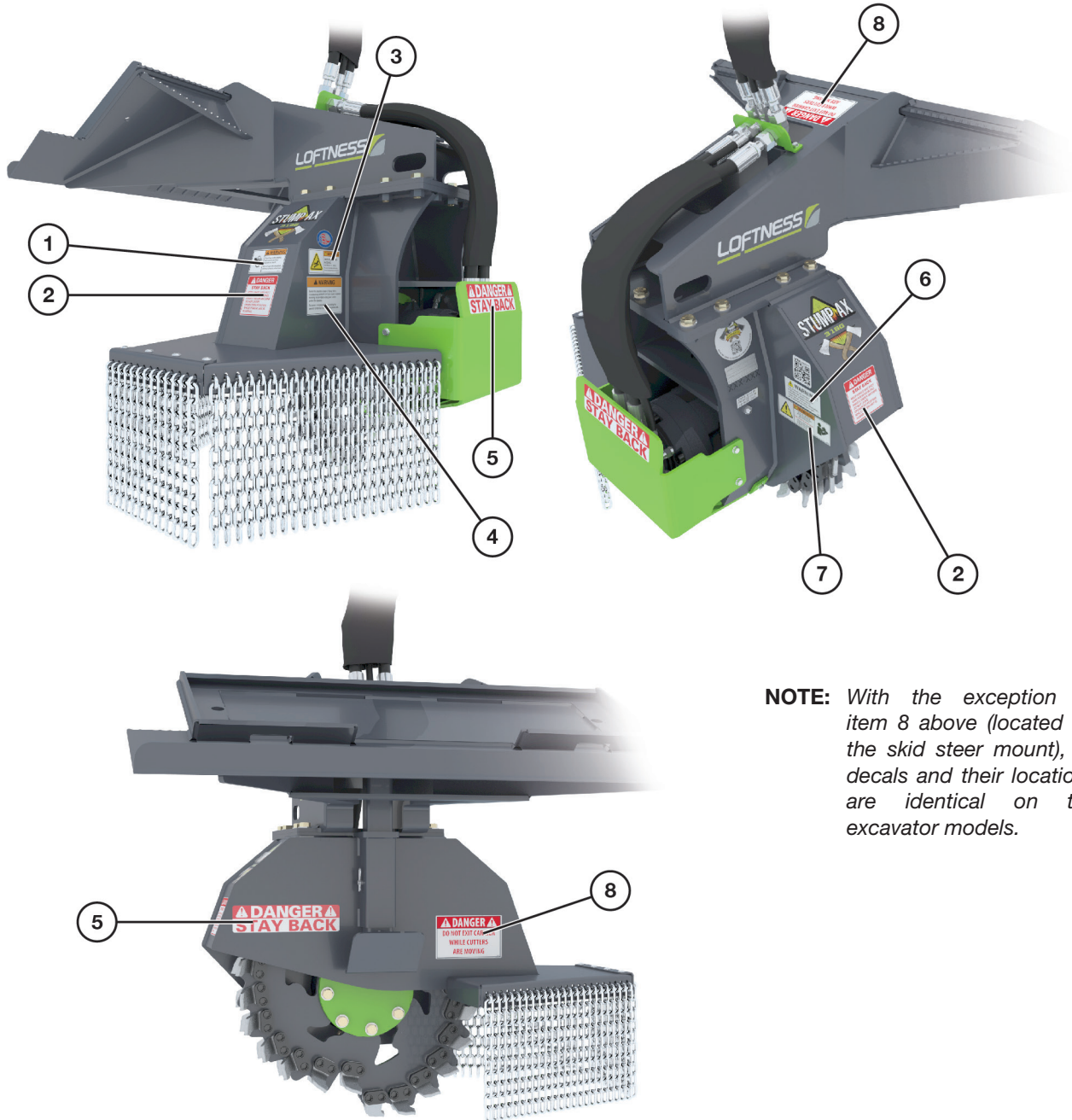

NOTE: With the exception of item 8 above (located on the skid steer mount), all decals and their locations are identical on the excavator models.

See page 12 for detailed images of the safety decals called out above.

Safety Instructions

Safety Decal Locations (Cont'd)



Part No. N68716



Part No. 4334



Part No. N28386



Part No. 203264



Part No. N23506

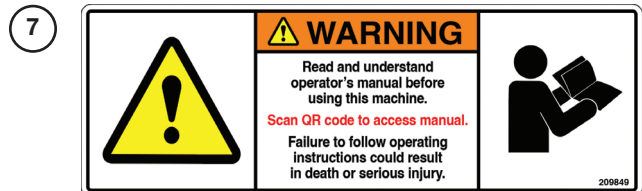

Part No. 209849

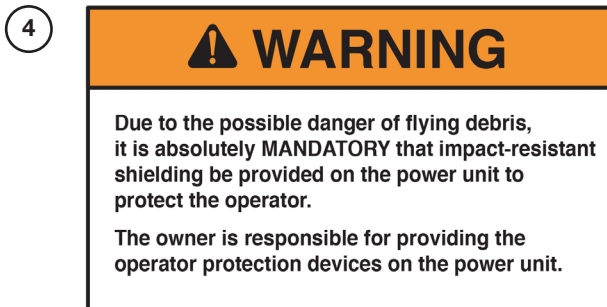

Part No. N17013



Part No. 200491

Set-up Instructions

Attaching the Stump Ax to a Skid Loader

Fully raise the attachment-locking levers on the loader mounting plate.

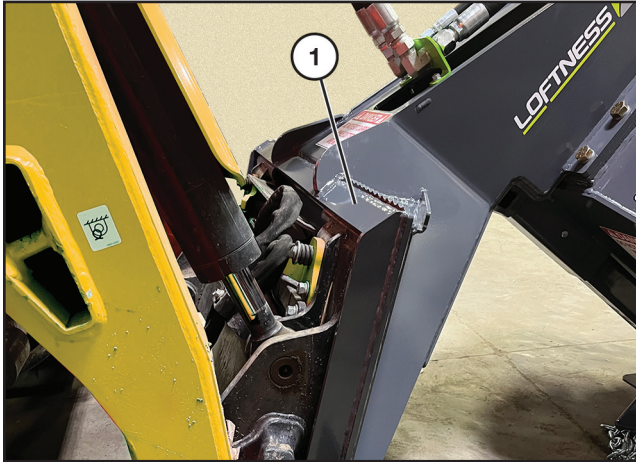

Tilt the loader mounting plate ahead. Drive forward with the loader and hook the top edge of the loader mounting plate under the top flange (1) on the Stump Ax mounting plate. Be careful not to damage the locking levers on the loader mounting plate.

Tilt the loader mounting plate back until the stump grinder mounting plate is firmly against the loader mounting plate, but Do Not lift the attachment off the ground.



WARNING: Before you leave the operator's seat: Lower the lift arms, put the attachment on the ground. Stop engine and remove ignition key. Engage the parking brake.

Fully lower the attachment-locking levers on the loader mounting plate.



WARNING: Locking-wedge pins must extend through the holes in attachment-mounting plate. Levers must be fully down in the locked over-center position. Failure to secure wedge pins can allow attachment to come off, causing serious injury or death.

Hydraulic Connections



WARNING: Hydraulic Lines. Protect hands and body from high pressure fluids. Pressurized fluids can penetrate the skin. Disconnect and lock out power source before disconnecting and/or connecting hydraulic hoses.

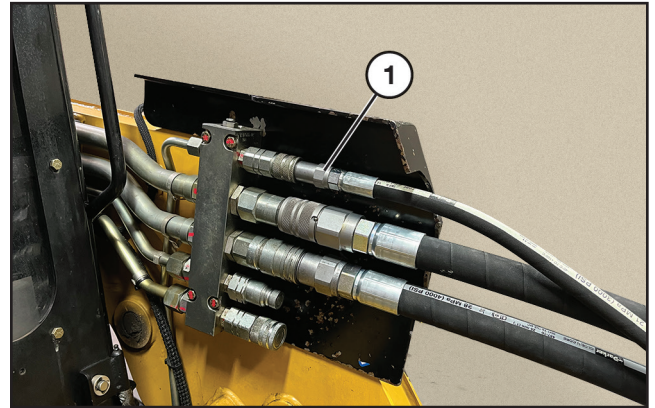

Install the Stump Ax quick couplers to the loader.

NOTE: The case drain quick coupler (1) must be connected to the loader's auxiliary hydraulic system for proper operation of the Stump Ax.

IMPORTANT: It is the owner's responsibility to assure that the hydraulic hoses from the power unit to the attachment are not caught in pinch points, or in any way damaged by moving parts.

Set-up Instructions

Attaching Stump Ax to an Excavator

For a mounting bracket specific to your model of excavator, contact Loftness.

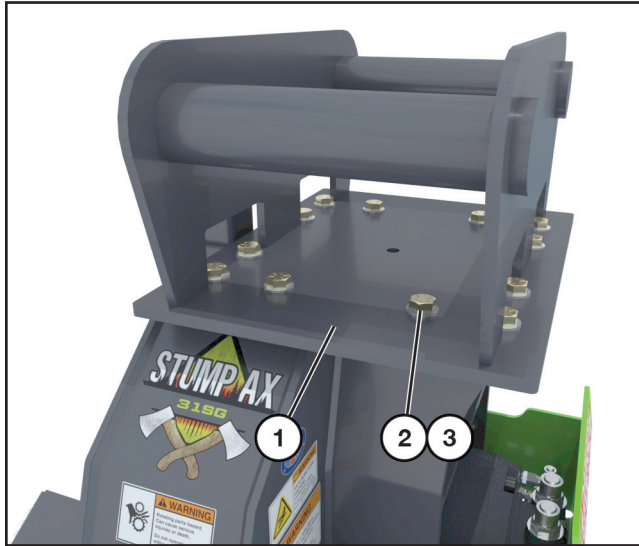

Align the holes in the excavator mount (1) to the holes in the mounting plate on top of the stump grinder housing. Insert the eight bolts (2) with washers (3) and thread into the weld nuts on the housing frame.

Align excavator boom and connect to the mounting bracket.

Verify connection from the excavator to the mounting bracket is secure.

Hydraulic Connections

NOTE: Hoses and couplers from the excavator to the Stump Ax are NOT included.



WARNING: Hydraulic Lines. Protect hands and body from high pressure fluids. Pressurized fluids can penetrate the skin. Disconnect and lock out power source before disconnecting and/or connecting hydraulic hoses.

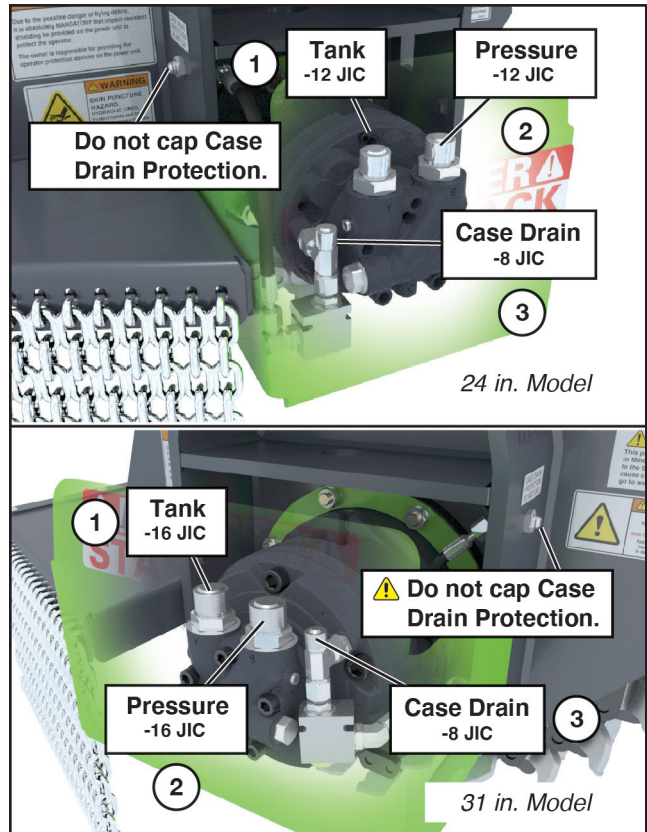

Connect hydraulic hoses (not included with the Stump Ax) from the excavator to the Stump Ax. See below for hose requirements.

	24" Model	31" Model
1. Tank	-12 JIC	-16 JIC
2. Pressure	-12 JIC	-16 JIC
3. Case Drain	-8 JIC	-8 JIC

IMPORTANT: Always set the auxiliary hydraulic circuit on your power unit to "One Way/Continuous Flow" mode.

Minimum case drain hose size is 3/4 in. when used on an excavator. It is recommended that the hose connects directly to the hydraulic reservoir.

NOTE: Use hoses that are the same diameter size as those used on the hydraulic motor. Using smaller diameter hoses will decrease hydraulic efficiency.

IMPORTANT: It is the owner's responsibility to assure that the hydraulic hoses from the power unit to the attachment are not caught in pinch points, or in any way damaged by moving parts.

Set-up Instructions

Jack Stand (Skid Loader models)

Raising the Jack Stand



CAUTION: The jack stand must be in the raised position during operation. Operating the Stump Ax with the jack stand in the lowered position could result in machine damage. Follow the procedure below for raising the jack stand before operation.

Once securely attached to the mounting plate of the power unit, use the power unit hydraulics to slowly lift the stump grinder a few inches off of the ground.



DANGER: Shut down and lock out power from the power unit before raising the jack stand. Failure to do so could result in serious injury or death.

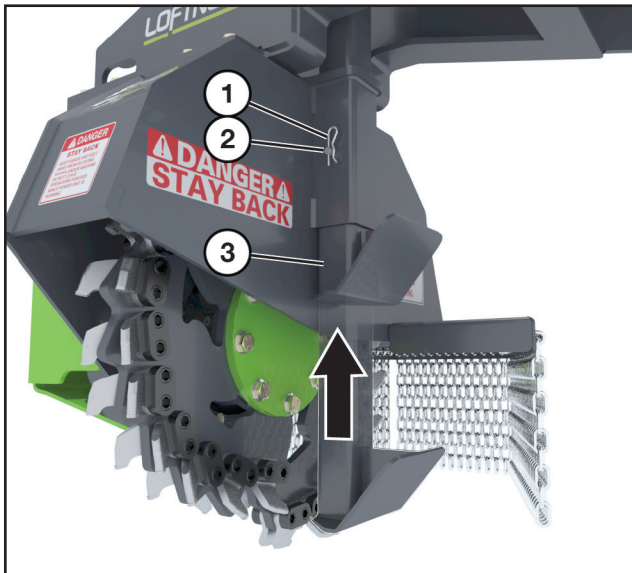

Once the stump grinder is raised and the power unit is shut down, remove the key (1) and pin (2) securing the jack stand (3).

Slide the jack stand UP into the frame until the hole near the base (4) aligns with the hole for the hardware to put the stand in the up position.

Reinsert the pin and secure with the key.

Lowering the Jack Stand (Storage)

With the Stump Ax raised and the power unit shut down, slide the jack stand DOWN until the hole near the top of the stand aligns with the hole for the hardware to put the stand in the down position.

Return the hardware to its original position.

IMPORTANT: Keep the jack stand down to stabilize the Stump Ax whenever it is not attached to the power unit.

Checking Wheel Rotation

With the power unit running, and all hydraulic lines connected, raise the Stump Ax off the ground.

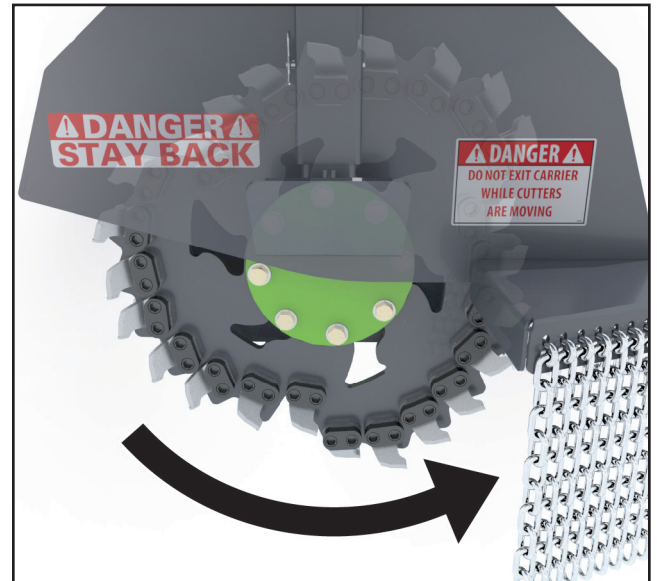

Engage the power unit auxiliary hydraulics, the wheel should start rotating in a counterclockwise direction as viewed from the cab of the power unit.



DANGER: Stay clear of the wheel while the power unit is running and the wheel is spinning. Contact with the wheel could result in serious injury or death.

NOTE: If the wheel does not rotate, shut down the power unit. Verify the pressure and tank hoses are connected to the correct couplers. Incorrect hose connections will prevent the Stump Ax from operating.



Getting Started

Pre-start Checklist

	DANGER: Shut down and lock out power from the power unit before performing the pre-start checklist. Failure to do so could result in serious injury or death.
---	--

Visually inspect the unit before starting the machine up. Check for loose or missing parts. Check all bolts for tightness.

- Make sure the Stump Ax is properly attached to the power unit.
- Check all bolts, nuts and set screws for tightness.
- Inspect the cutting teeth. If any are damaged or missing, replace. Make sure they are free of dried mud, string, wire, etc.

	WARNING: Never operate the Stump Ax with out-of-balance teeth. Check to make certain there are no cutting teeth missing and that all are installed securely.
--	---

	WARNING: DO NOT operate the Stump Ax with safety guards and/or deflector chains removed.
---	---

- Review operator's manual.

	WARNING: Due to the potential danger of flying debris, it is the owner's responsibility and is "ABSOLUTELY MANDATORY that IMPACT-RESISTANT SHIELDING" be installed on the machine to protect the operator.
---	---

For first-time users

- Stand to the side of the Stump Ax and look at the center point on the bottom of the wheel to become familiar with the cutting path of the wheel, which can be deceiving when sitting in the operator's seat of the power unit.
- Start the machine in a clear, open area and become familiar with the controls. Run throttle at half speed. Raise the stump grinder only slightly until comfortable with the machine.

	WARNING: Lifting or tilting the Stump Ax increases the risk of flying debris.
---	--

	DANGER: Keep hands and feet out! Do not step on or climb over the unit while machine is in operation, or engine is running. Do not carry passengers.
---	---

	WARNING: Do not operate the attachment above the rated RPM. Check with your Loftness dealer to be sure your attachment is set-up with the correct hydraulic motor to match the hydraulic flow GPM (Gallons Per Minute) of your machine.
---	--

	WARNING: Flying debris can gather on the power unit and needs to be cleaned off, especially around the radiator, oil cooler screens, engine compartment, and exhaust areas. Periodic cleaning will help prevent the possibility of fire.
---	---

	DANGER: DO NOT allow ANY people or animals within 300 feet of the work area while operating this machine.
---	--

	DANGER: Verify there are no underground utilities or pipelines in the area where the Stump Ax will be operating. Failure to do so could result in serious injury or death should the teeth come in contact with a utility line. If you are not sure, contact your local utility agency so the area can be marked.
---	--

	WARNING: Always stop engine and remove the key before leaving operators seat.
---	--

IMPORTANT: Upon initial use, to reduce stress on brand new cutting teeth and to extend their life, allow 2-3 hours of light-duty stump grinding for the teeth to wear gradually. Keep the wheel level and above ground when grinding, and avoid all contact with hard objects, rocks, and dirt.

Operating Instructions

General Operation and Cutting Instructions - Skid Loader models

- Align the cutting wheel to the front and right side of the stump (viewed from the operator's position). In this direction the wheel torques downward, pushing the frame up to avoid binding.
- Engage the cutting wheel and slowly lower it, adjusting the height so that it will cut no more than 4 inches deep.

IMPORTANT: Always lower the wheel so the center line of the cutting wheel is to the side of the stump. Do not cut down onto the stump.

- Slowly drive forward into the stump. If the cutting wheel stalls, stop motion and raise slightly. Continue moving forward.

NOTE: Travel speed and cutting rate will depend on the type of tree, condition of the stump, and the condition of the cutting teeth. On wet stumps, operate at a slower speed and periodically inspect the wheel for caking and clogging in the wheel area.

- After a complete pass, lower the skid loader arms 4 inches.
- Slowly drive backward to make a return pass into the stump.
- After a complete forward and backwards pass, reposition the skid loader and cutting wheel so that the cutting wheel is approximately 8-12 inches to the left of the previous cut.
- Continue working to the left in this manner until completely through the stump.
- Return to the right side of the stump, lower the cutting wheel (4 inches max.) and repeat the same procedure until the stump above ground is completely removed.

When reaching ground level, make certain that the area around the stump and roots are clear of any rocks and stones.

NOTE: Because of the high speed of the disc, the life of the teeth will be reduced if they consistently come in contact with dirt, sand, and rocks.

Continue removing the stump below ground level, following the same procedures as above but at a reduced travel rate.

NOTE: For residential worksites, keep turning (skidding) to a minimum to avoid damage to property.

Blade (Skid Loader models)

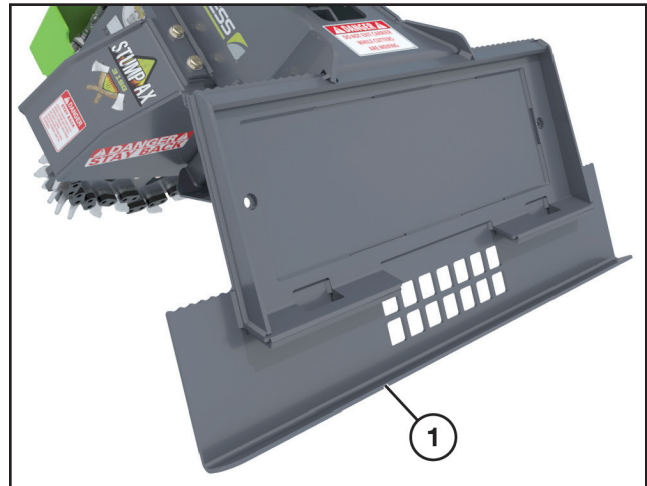

The skid loader mount is equipped with a blade (1) that allows the operator to clear and move stump debris from the work area.

Stopping the Stump Ax

Before making any inspections, adjustments, or maintenance, disengage the power unit's hydraulics and wait for the wheel to come to a complete stop.

Before dismantling the power unit, shut off the engine set the parking brake and remove the key.

Lower the jack stand into position.

Detaching Stump Ax from the Skid Loader

Park on clear, level ground with enough room to lower the Stump Ax.

Lower the jack stand. See "Jack Stand (Skid Loader models)" on page 15 for jack stand instructions.

Lower the stump grinder until it is sitting firmly on the jack stand and the blade.

Disconnect the loader from the Stump Ax.

Clean the Stump Ax after every use.

General Operation and Cutting Instructions - Skid Loader models (Cont'd)

Hose Storage (Skid Loader models)



When not in use, protect the hose couplers by routing the hydraulic hoses into the opening on the mount as shown. Ensure the couplers do not come in contact with the machine, ground, or any other surface.

General Cutting Instructions - Excavator models

- Align the cutting wheel to the back and right side of the stump (viewed from the operator's position).
- Engage the cutting wheel and slowly lower it, adjusting the height so that it will cut no more than 4 inches.

IMPORTANT: Always lower the wheel so the center line of the cutting wheel is to the side of the stump. Do not cut down onto the stump.

- Slowly swing into the stump. If the cutting wheel stalls, stop motion and raise slightly.

NOTE: Travel speed and cutting rate will depend on the type of tree, condition of the stump, and the condition of the cutting teeth. On wet stumps, operate at a slower speed and periodically inspect the wheel for caking and clogging in the wheel area.

- After a complete pass to the left, reposition the cutting wheel approximately 8-12 inches closer to the front of the stump.
- Make a pass to the right.
- Continue this procedure across the entire stump.
- Reposition the cutting wheel to the back and right side of the stump. Lower the cutting wheel 4" and repeat the same procedure until the stump above ground is completely removed.

When reaching ground level, make certain that the area around the stump and roots are clear of any rocks and stones.

NOTE: Because of the high speed of the disc, the life of the teeth will be reduced if they consistently come in contact with dirt, sand, and rocks.

Continue removing the stump below ground level, following the same procedures as above but at a reduced travel rate.

NOTE: For residential worksites, keep turning (skidding) to a minimum to avoid damage to property.

Detaching Stump Ax from the Excavator

Park excavator on a dry level surface. Turn power off to the Stump Ax.

Lower the Stump Ax until it is sitting on the stand.

Shut off engine and remove key.

Disconnect hydraulic hoses.

Detach excavator boom from the mounting bracket.



WARNING: Do not attempt to detach the Stump Ax while the excavator is running. Shut down and lock out power from the excavator before detaching.

Operating Instructions

Transporting

Road Travel

	CAUTION: <i>Always comply with all federal, state and local laws when traveling on public roads whether at night or during the day. Use accessory lights and devices for adequate warning to operators of other vehicles.</i>
---	--

Disengage hydraulics.

Raise the Stump Ax high enough so that the wheel can not come in contact with the ground during travel. Ensure the operator has a clear vision of the path ahead.

Select a safe ground travel speed when transporting from one area to another. Reduce ground speed when turning.

Hauling

When transporting the Stump Ax on a trailer or on a truck, make sure the machine is properly and safely tied down and secure.

	WARNING: <i>Failure to secure the Stump Ax when transporting could result in serious injury or death to surrounding.</i>
---	---

General Maintenance

IMPORTANT: Refer to “Maintenance Safety” on page 7 and become familiar with the safety rules before performing any maintenance or service on the Stump Ax.

To ensure efficient operation, you should inspect, lubricate, and make necessary adjustments and repairs at regular intervals. Parts that are starting to show wear should be ordered ahead of time, before a costly breakdown occurs and you have to wait for replacement parts. Keep good maintenance records, and adequately clean your stump grinder after each use.

Proper lubrication is important. Too little lubricant will cause premature failure of a bearing. Too much lubrication usually causes high operating temperature and early failure of seals. Follow all lubrication instructions and schedules included in this section.

Break-In Schedule

Inspect and service after one (1) hour of operation all bolts, teeth, and motor mount.

Regular maintenance should then be followed thereafter. Refer to the chart below for the maintenance schedule.

Maintenance Schedule

INTERVAL	SERVICE POINTS	SERVICE REQUIRED					
		CHECK	CLEAN	CHANGE	GREASE	ADJUST	OIL
Every 8 hr.	Machine		X				
	Loose Bolts					X	
	Hoses	X					
	Oil Leaks	X					
	Teeth	X					
Every 100 hr.	Safety Labels	X					
Yearly	Bearing Support			X			

Lubrication

Changing Bearing Support Gear Lube



DANGER: Shut down power from the power unit before changing the gear lube.

Position the Stump Ax so it is sitting level.

The motor cover must be removed to access the bearing support ports. Refer to “Removing the Motor Cover” on page 22 for instructions.

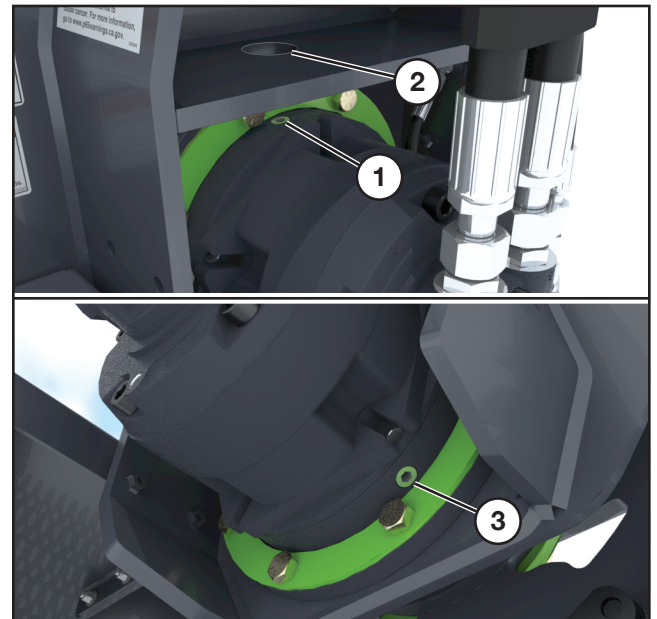

Remove the plug from port (1) located on the top of the bearing support - use the through hole (2) provided in the frame for access.

Place a container underneath the lower port (3) of the bearing support - large enough to hold 30 oz. of fluid, then remove the plug from the lower port. Allow the fluid to drain completely. Reinsert the plug into the lower port and tighten.

Add 80W-90 gear lube listed below through the top port (1).

24" models - 11 oz.
31" models - 40 oz.

When complete, reinsert the plug into the top port and tighten.

Reinstall the motor cover.

Maintenance

Removing the Motor Cover

 **DANGER:** Shut down power from the power unit before removing the motor cover.

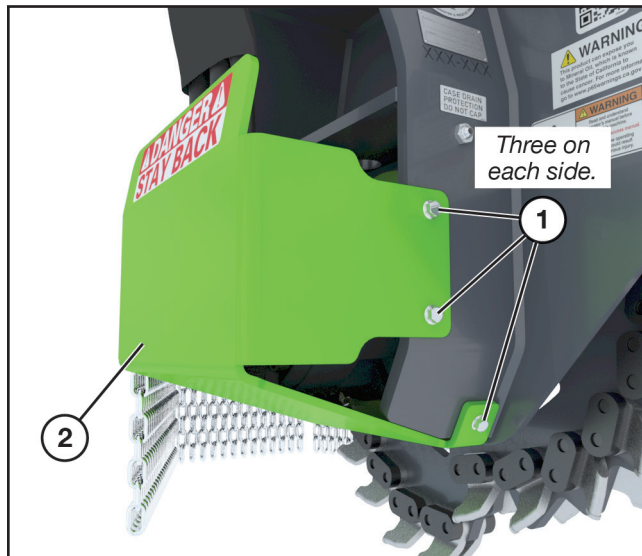

With an 9/16" socket, remove the eight bolts (1) securing the motor cover (2) - four bolts on each side.

Reverse the procedure to return cover and hose holder to position.

Tooth Removal and Installation

 **DANGER:** Shut down power and disconnect hydraulic supply from the power unit before removing and replacing teeth.

NOTE: The wheel must be stabilized to remove the cutting teeth.

There are two teeth per tooth set.

Make note of the tooth direction and assembly order before removing to ensure the new teeth are installed correctly.

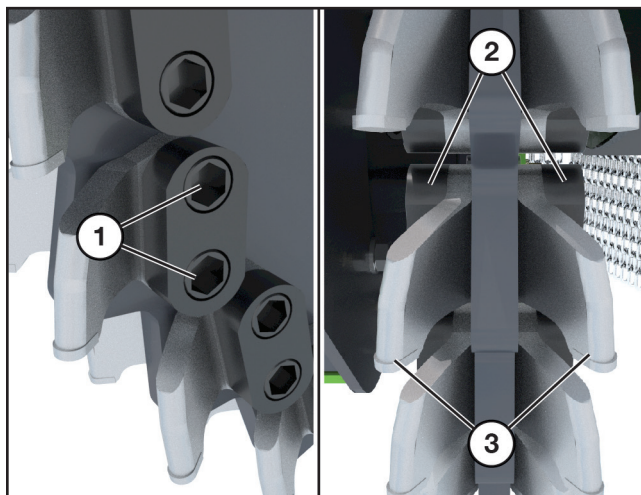

Use a 5/8" Allen wrench to remove the two bolts (1) securing the two mounting blocks (2) and cutting teeth (3).

When reinstalling the teeth and mounting blocks, apply anti-seize to the mounting blocks and to the holes on the wheel.

Torque to 120-150 ft.-lbs. when reinstalling the bolts.

Wheel Removal

IMPORTANT: *The Stump Ax should be disconnected from the power unit for this procedure.*

	<p>DANGER: Crushing Hazard. <i>Failure to safely secure and lift the Stump Ax could result in severe injury or death. Use a power hoist and lifting equipment and allow only trained personnel to lift the Stump Ax.</i></p>
---	---

NOTE: *The hoist/lifting device and chains or strap must be in good condition and of adequate size to lift the Stump Ax.*

	<p>CAUTION: <i>The teeth on the wheel are sharp. Wear gloves during this procedure to avoid getting cut while handling the wheel.</i></p>
---	--

Lift the Stump Ax enough so that a hydraulic table, or jack, can be positioned under the wheel and also provide enough room for the wheel to clear the machine housing when being pulled out.

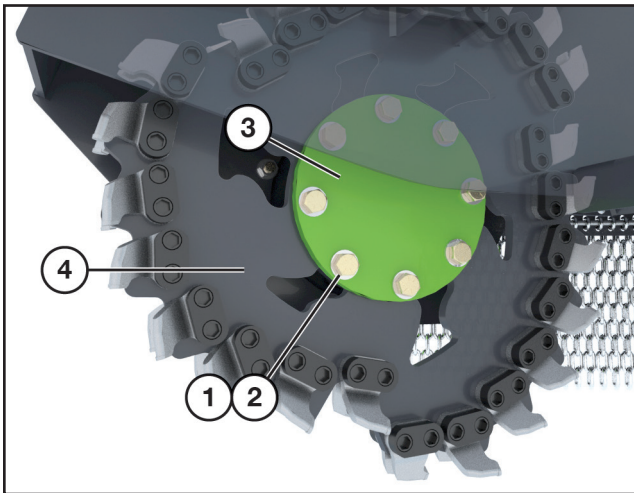

Using a 1-1/8" socket, begin to loosen all eight bolts (1) and washers (2) securing the wheel plate (3) and wheel (4) to the drive.

	<p>CAUTION: <i>The wheel is heavy. Use a second person to assist with lifting.</i></p>
---	---

With the wheel fully supported, begin removing the bolts and washers.

Remove the wheel plate followed by the wheel using a second person and the hydraulic table, or jack, for assistance.

Reverse the process to reinstall the wheel, wheel plate, and hardware.

Torque all eight bolts to 293 ft.-lbs. when reinstalling.

Storage

End of Season

- Clean the entire Stump Ax thoroughly.
- Change lube in the bearing support. See “Changing Bearing Support Gear Lube” on page 21.
- Make a list of all worn or damaged parts and replace them.
- Paint all parts that are worn or rusted.
- Store the Stump Ax in a clean, dry area.
- Review the Stump Ax operator’s manual.
- Secure hydraulic hoses in storage position. See “Hose Storage (Skid Loader models)” on page 19.

Beginning of the Season

- Review the Stump Ax operator’s manual.
- Tighten all bolts, nuts, and set screws. See “Torque Specifications” on page 54.
- Replace all damaged, worn or missing decals.
- Install the Stump Ax to a power unit and test for proper operation.

Maintenance

GPM Chart

110cc Instant Torque Radial Piston Motor - 24" Model

GPM	Wheel RPM	Displacement	Loftness Part number
17	585	110 Max Displacement	SAI 209967
18	619		
19	654		
20	688		
21	723		
22	757		
23	791		
24	826		
25	860		
26	895		
27	929		
28	964		
29	998		
30	1032		
31	1067		
32	1101		
33	1136		
34	1170		
35	1204		
36	1239		

GPM Chart

200cc Instant Torque Radial Piston Motor - 31" Model

GPM	Wheel RPM	Displacement	Loftness Part number
30	568	200 Max Displacement	SAI 209567
31	587		
32	606		
33	625		
34	644		
35	662		
36	681		
37	700		
38	719		
39	738		
40	757		
41	776		
42	795		
43	814		
44	833		
45	852		
46	871		
47	890		
48	908		
49	927		
50	946		
51	965		
52	984		
53	1003		
54	1022		
55	1041		
56	1060		
57	1079		
58	1098		
59	1117		
60	1136		

Maintenance

Troubleshooting

PROBLEM	CAUSE	SOLUTION
Excessive Vibration	Broken or missing teeth.	Replace teeth.
	Mud and/or debris wrapped around the disc.	Clean the stump grinder.
	Damage to wheel (includes bent spindle or actual wheel deformity from striking rocks, etc.)	Consult factory.
Uneven Cutting	Teeth dull or worn excessively.	Replace teeth.
	Engine RPM too slow.	Adjust machine RPM to full throttle.
	Travel speed too fast.	Reduce ground speed.
Wheel Will Not Turn	Low oil.	Check oil level in the power unit. Add if necessary.
	Low oil flow.	Check flow control on the power unit.
	Oil filter plugged.	Replace the power unit oil filter.
	Wheel jammed.	Remove material from disc.
	Hydraulic hose connections are incorrect.	Connect pressure and tank hoses to the correct couplers
Oil Leak at Case Drain Protection Port.	Pinched case drain hose.	Check hose.
	Disconnected case drain hose.	Reconnect hose.



PARTS IDENTIFICATION

NOTE: For service and replacement parts, be sure to specify which Stump Ax model/size you have.

Parts Identification

Housing; Disc, Motor - 24" Model

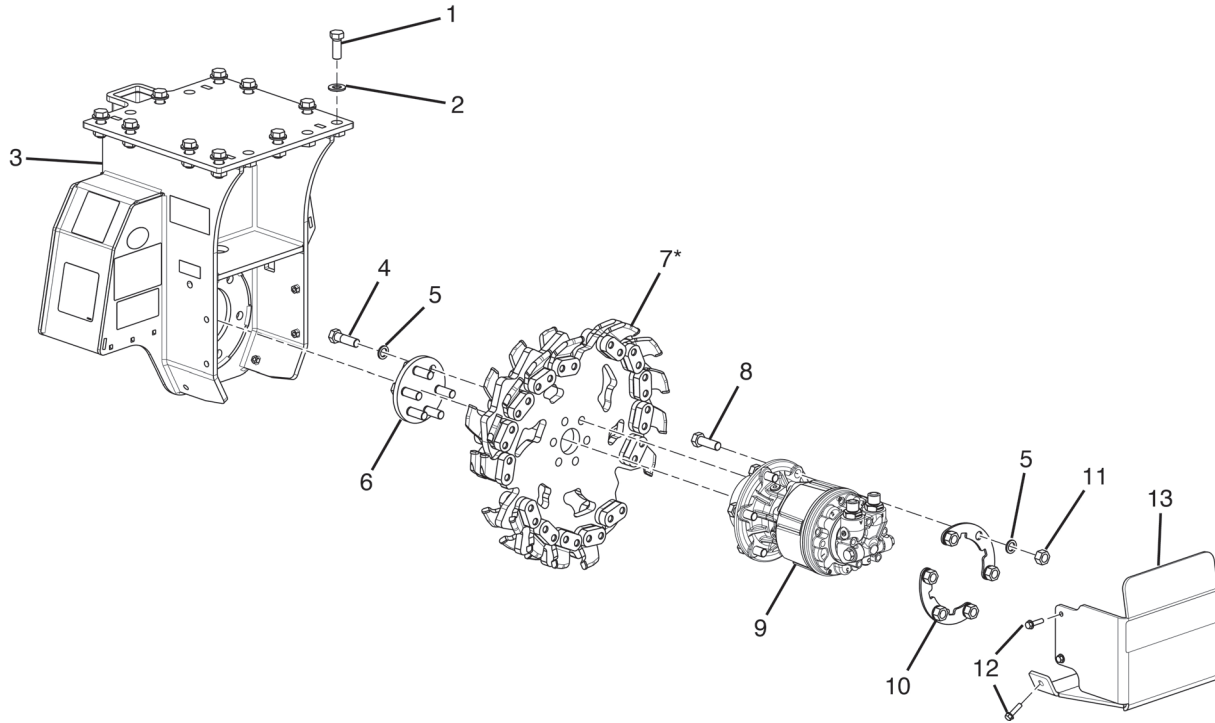

* For parts breakdown of item 7 - Wheel (209966), see page 40.

#	QTY.	PART #	DESCRIPTION
1	10	212418	BOLT, 3/4" X 2" UNC GR 8
2	10	N28567	WASHER, 3/4 NORDLOCK SP
3	1	212701	HOUSING, DISC W/ DECALS 24
4	6	208780	BOLT, 3/4" X 2-1/2" GRADE 8
5	12	N16474	WASHER, 3/4 NORDLOCK
6	1	212077	PLATE, DISC 24
7	1	209966	WHEEL, 24 PHANTOM STUMP GRIND
8	6	4343	BOLT, 3/4" X 2-1/4" FN TH GR 8
9	1	209967	MOTOR, SAI 110CC
10	2	212076	PLATE, WASHER 24
11	6	4341	NUT, 3/4" FINE THREAD GRADE 8
12	6	N37775	BOLT, 3/8" X 1-1/2" SER FLG
13	1	212704	COVER, STUMP AX MOTOR 24 PRO

Housing; Disc, Motor - 31" Model

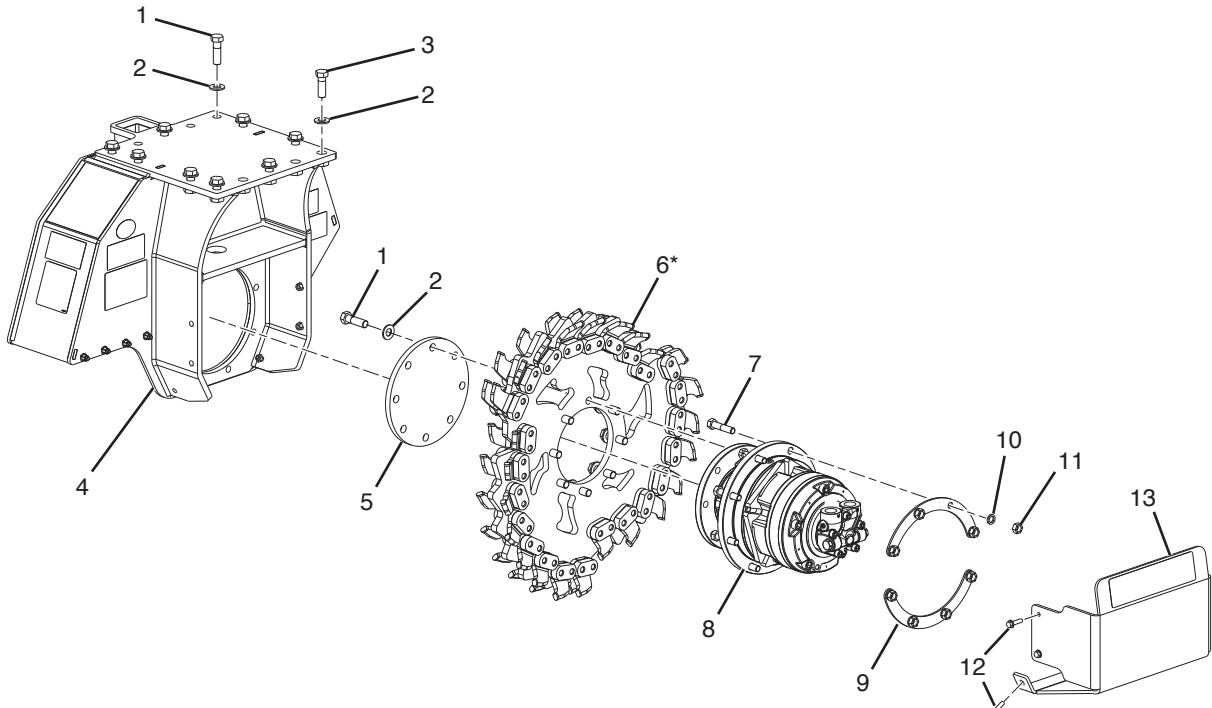

* For parts breakdown of item 6 - Wheel (209433), see page 41.

#	QTY.	PART #	DESCRIPTION
1	13	208780	BOLT, 3/4" X 2-1/2" GRADE 8
2	18	N16474	WASHER, NORD-LOCK 3/4"
3	5	212418	BOLT, 3/4IN X 2IN UNC GR 8
4	1	212713	HOUSING, DISC W/ DECALS
5	1	209432	PLATE, DISC
6	1	209433	WHEEL, 31 PHANTOM STUMP GRIND
7	8	N28675	BOLT, 5/8" X 2-3/4" GRD 8 FN
8	1	209576	MOTOR, SAI 200CC NO RELIEF
9	2	209381	PLATE, WASHER C
10	8	N16473	WASHER, NORD-LOCK 5/8"
11	8	4452	NUT, STANDARD 5/8"FN THD GR8
12	8	N37775	BOLT, 3/8" X 1-1/2" SER FLG
13	1	212715	COVER, STUMP AX MOTOR

Parts Identification

Lubrication; Relief Manifold - 24" Model

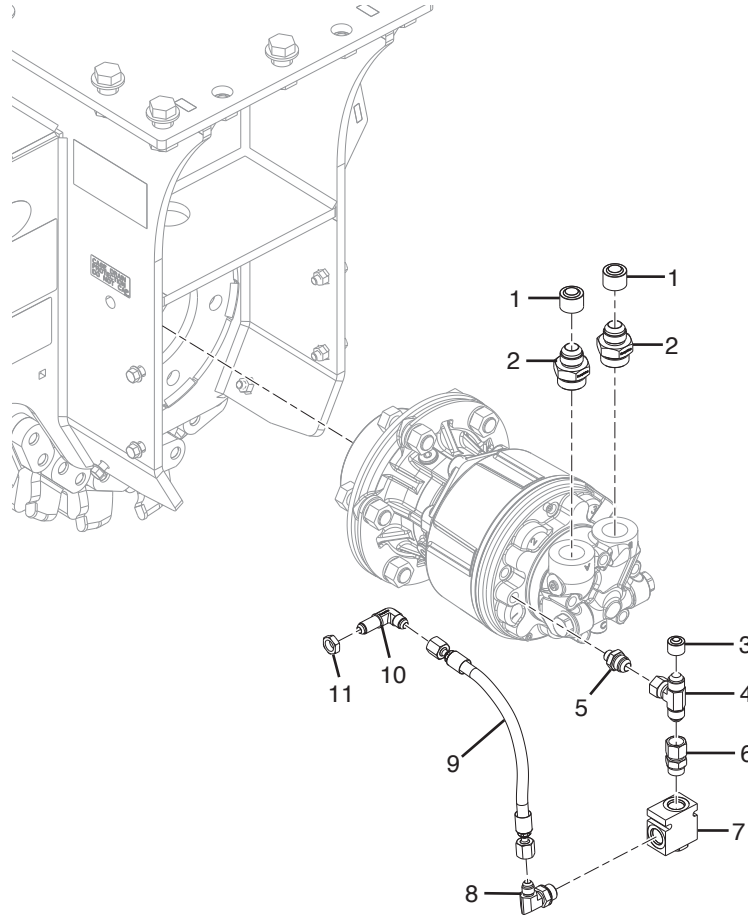

#	QTY.	PART #	DESCRIPTION
1	2	N15893	CAP, 3/4 ALUMINUM HOSE
2	2	N13881	ADAPTER, 16MOR -12MJIC
3	1	N15895	CAP, 1/2 ALUMINUM HOSE
4	1	N28895	TEE, 8MJIC-8MJIC-8FJIC
5	1	209653	ADAPTER, -8MJIC -4MBSPP
6	1	N24835	ADAPTER, 8MOR - 8FJIC
7	1	N157054	VALVE, RELIEF 100PSI
8	1	N20037	ELBOW, 90 DEG - 6MJIC - 8MOR
9	1	212140	HOSE, 1/4 X 13.00 -6FJIC -6FJIC
10	1	N28429	ADAPTER, 90 BULKHEAD -6MJIC
11	1	N24780	NUT, LOCK BULKHEAD -6

Lubrication; Relief Manifold - 31" Model

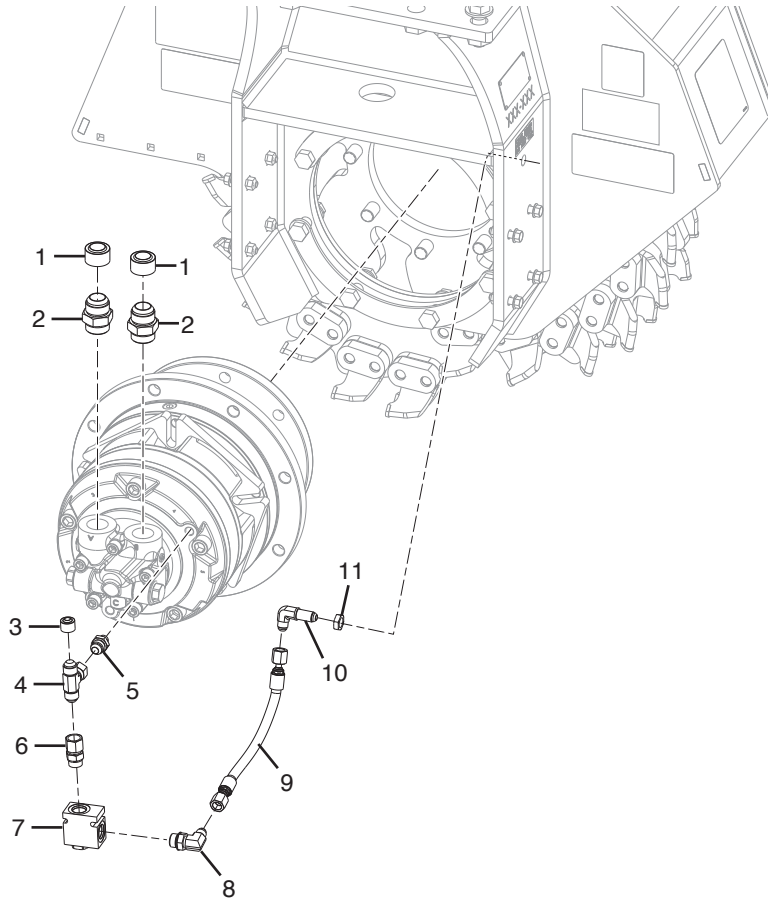

#	QTY.	PART #	DESCRIPTION
1	2	N28470	CAP, ALUMINUM HOSE -16
2	2	N19267	ADAPTER, 16MJIC - 16MOR
3	1	N15895	CAP, 1/2 ALUMINUM HOSE
4	1	N28895	TEE, 8MJIC-8MJIC-8FJIC
5	1	209653	ADAPTER, -8MJIC -4MBSPP
6	1	N24835	ADAPTER, 8MOR - 8FJIC
7	1	N157054	VALVE, RELIEF 100PSI
8	1	N20037	ELBOW, 90 DEG - 6MJIC - 8MOR
9	1	209656	HOSE, 1/4 X 11.00 -6FJIC -6FJIC
10	1	N28429	ADAPTER, 90 BULKHEAD -6MJIC
11	1	N24780	NUT, LOCK BULKHEAD -6

Parts Identification

Deflector Assembly - 24" Model

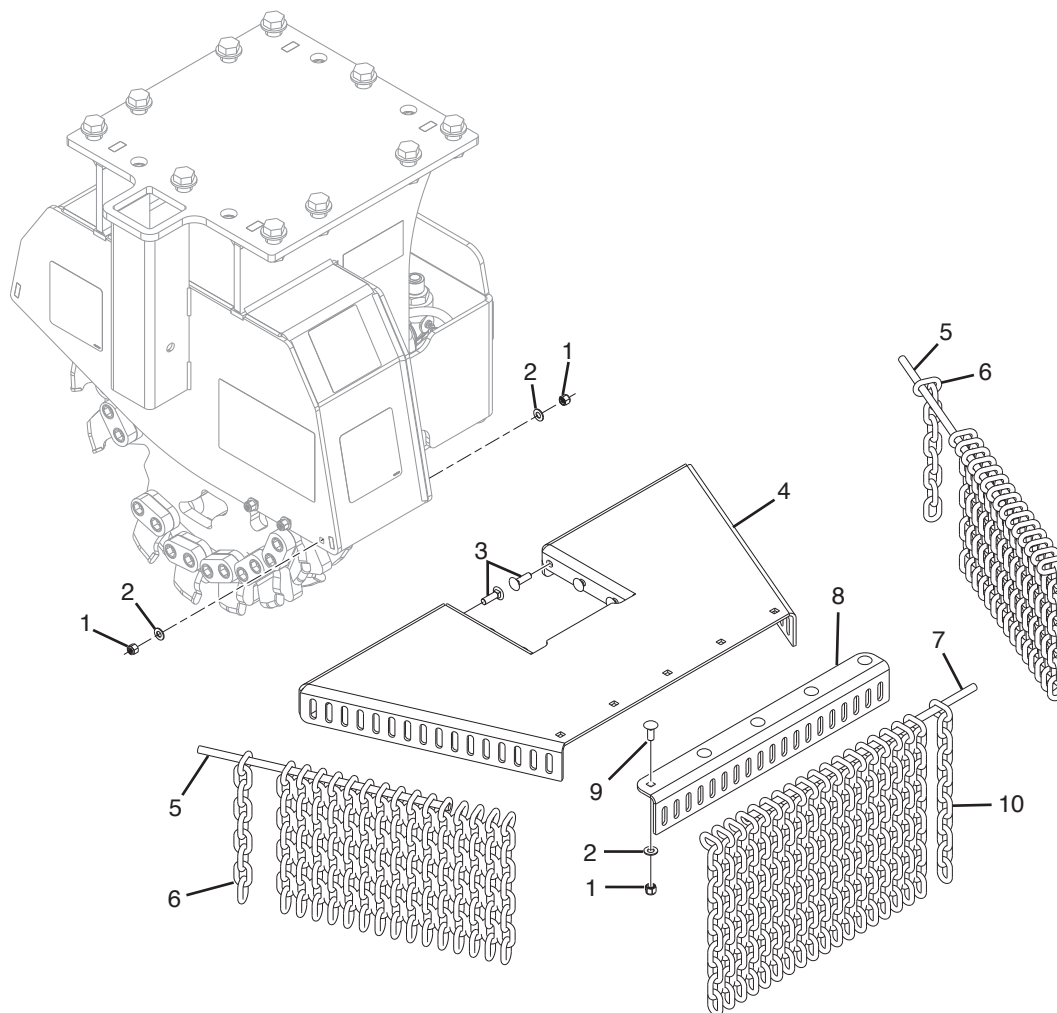

#	QTY.	PART #	DESCRIPTION
1	11	209887	NUT, LOCK 3/8IN-16 NYLOCK
2	11	N31741	WASHER, FLAT 3/8" SAE
3	6	4390	BOLT, 3/8" X 1-1/4" CARRIAGE
4	1	212396	PLATE, CHAIN HOLDER 24 G2
5	2	212398	ROD, STUMP GRINDER CHAIN S
6	32	202879	CHAIN, 5/16 DEFLECTOR 9 LINK
7	1	212399	ROD, STUMP GRINDER CHAIN L
8	1	212397	PLATE, CHAIN HOLDER END G2
9	5	4034	BOLT, CARRIAGE 3/8" X 1"
10	19	N13800	CHAIN, 5/16 DEFLECTOR

Deflector Assembly - 31" Model

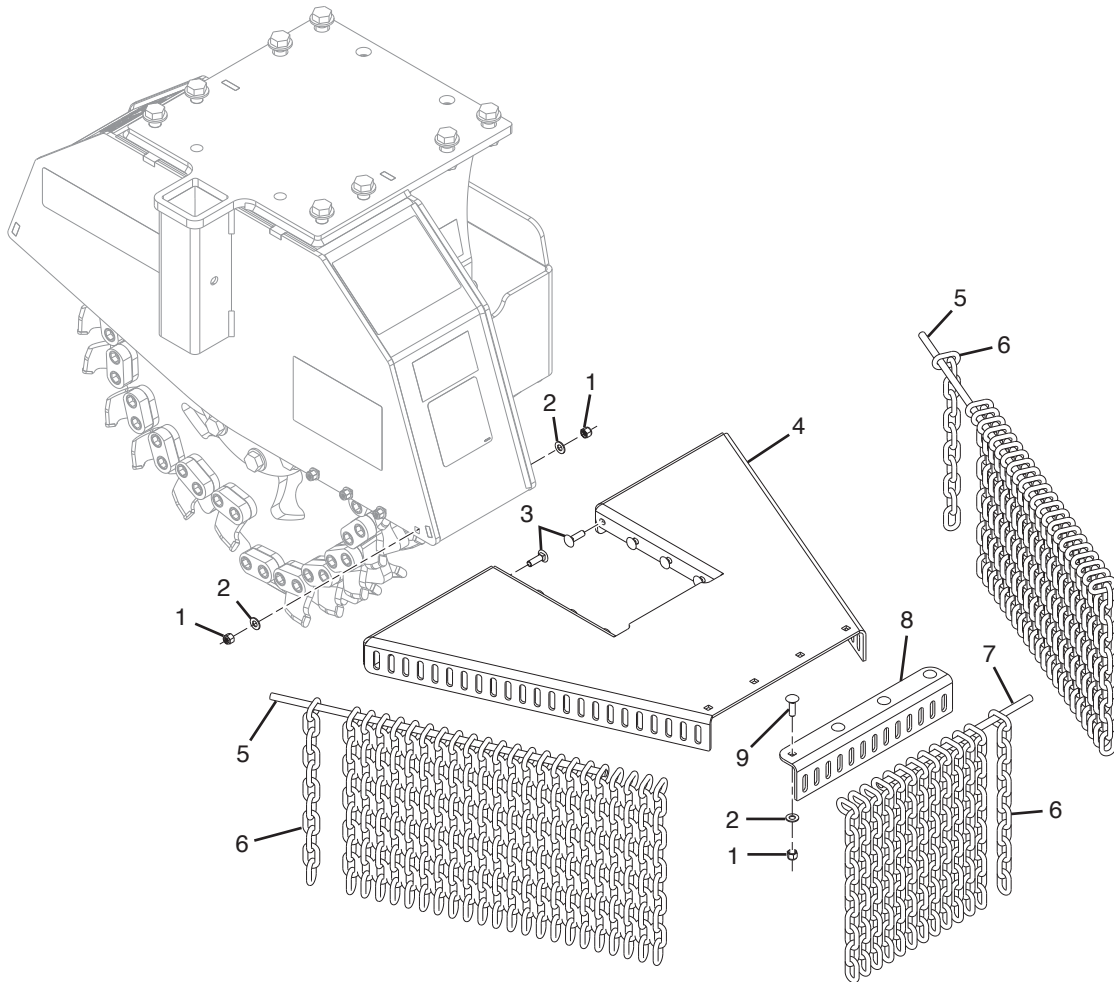

#	QTY.	PART #	DESCRIPTION
1	12	209887	NUT, LOCK 3/8IN-16 NYLOCK
2	12	N31741	WASHER, FLAT 3/8" SAE
3	8	4390	BOLT, 3/8" X 1-1/4" CARRIAGE
4	1	212000	PLATE, CHAIN HOLDER
5	2	212003	ROD, STUMP GRINDER CHAIN L
6	59	N13800	CHAIN, 5/16 DEFLECTOR
7	1	212004	ROD, STUMP GRINDER CHAIN S
8	1	212001	PLATE, CHAIN HOLDER END
9	4	4034	BOLT, CARRIAGE 3/8" X 1"

Parts Identification

Mount, Jack, Hydraulic Group

- * For parts breakdown of item 5 (shaded):
- 24" Hydraulic Group (212402), see page 36.
- 31" Hydraulic Group (212417), see page 38

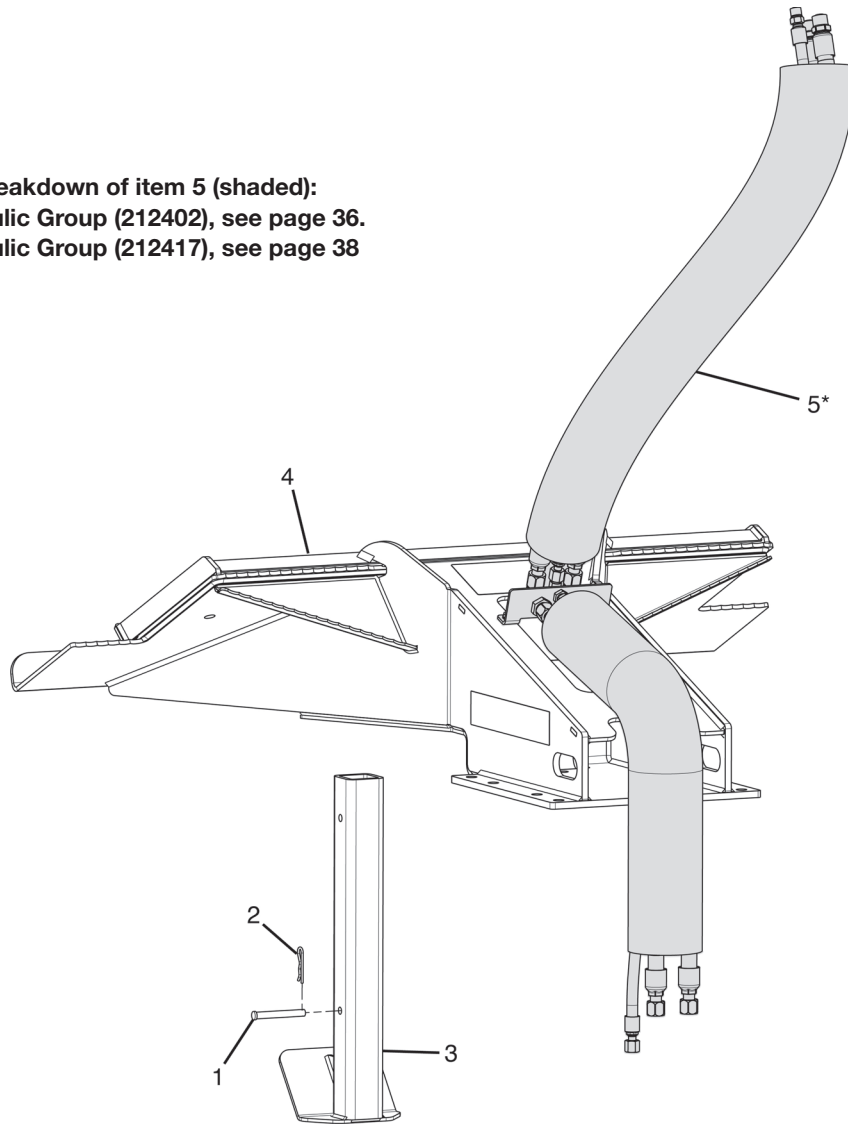

#	QTY.	PART #	DESCRIPTION
1	1	4242	PIN, 1/2IN X 3-3/4IN PLATED
2	1	4393	CLIP, HAIRPIN 5/32" X 2-1/2"
3	1	212381	STAND, FIXED STUMP GRINDER 24
	1	212413	STAND, FIXED STUMP GRINDER 31
4	1	212401	MOUNT, STUMP GRINDER UNIVERSAL
5	1	212402	GROUP, STUMP GRINDER HYD 24 G2 - (24" model)
	1	212417	GROUP, STUMP GRINDER HYD 31 FIXED - (31" model)

This page intentionally left blank.

Parts Identification

Hydraulic Group (212402) - 24" Model

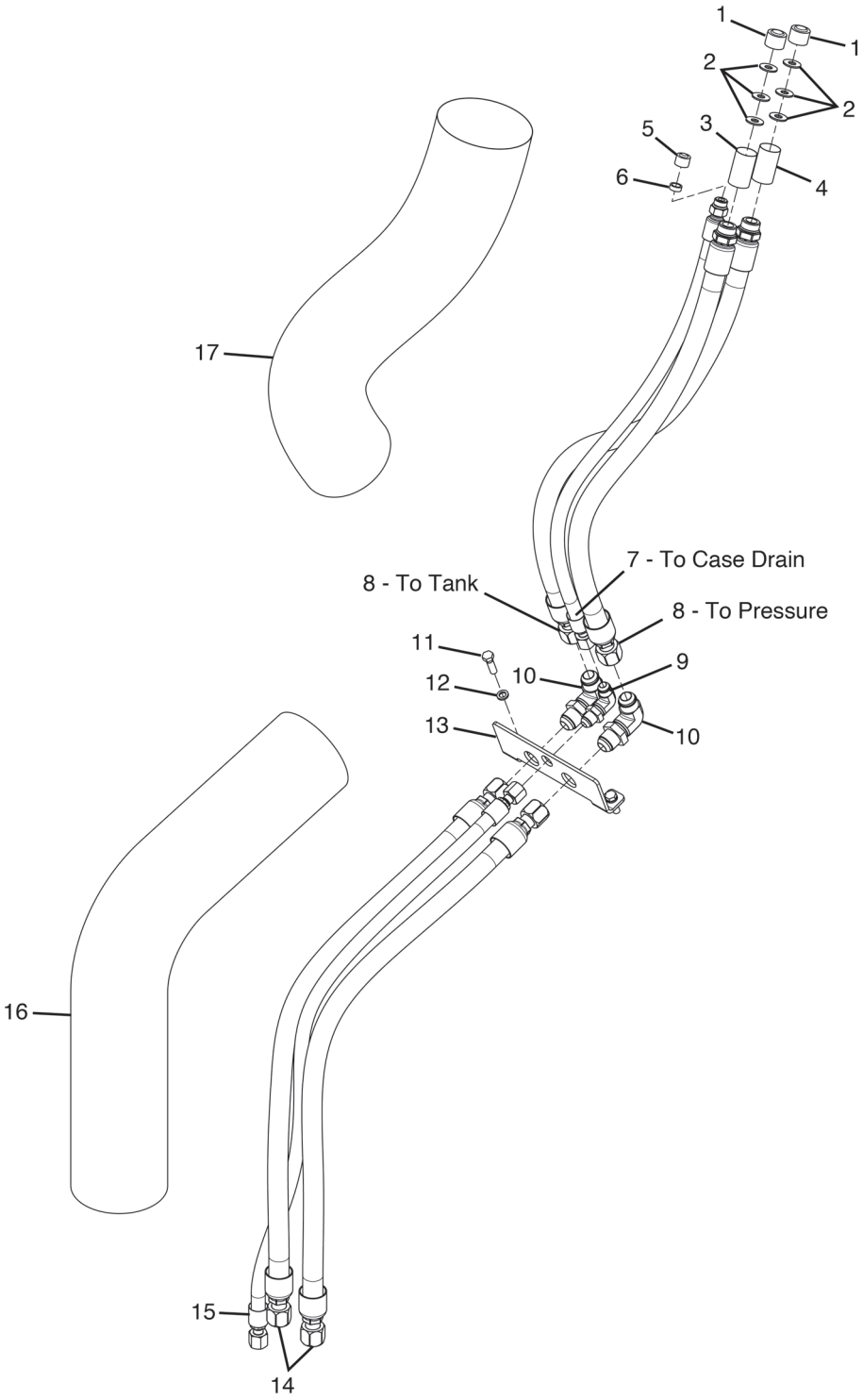

Parts Identification

Hydraulic Group (212402) - 24" Model

#	QTY.	PART #	DESCRIPTION
1	2	N15893	CAP, 3/4 ALUMINUM HOSE
2	6	4064	WASHER, FLAT 3/8"
3	1	N24822	DECAL, PRESSURE
4	1	N24823	DECAL, RETURN
5	1	N15895	CAP, 1/2 ALUMINUM HOSE
6	1	N32002	PLUG, 3/8 SCH 40 X .25
7	1	212409	HOSE, 1/2 X 78 -8FJIC -8MORB
8	2	212405	HOSE, 3/4 X 78 -12FJIC -12MORB
9	1	N28885	ADAPTER, 90 BULKHEAD -8MJIC
10	2	N34029	ADAPTER, 90 BULKHEAD -12MJIC
11	2	4005	BOLT, 3/8" X 1-1/4" GRADE 5
12	2	N16470	WASHER, 3/8 NORDLOCK
13	1	212125	PLATE, BULKHEAD HOLDER 24
14	2	212403	HOSE, 3/4 X 40 -12FJIC -12FJIC
15	1	212407	HOSE, 1/2 X 43 -8FJIC -8FJIC
16	1	212411	WRAP, HOSE 36
17	1	N88334	WRAP, HOSE 70

Parts Identification

Hydraulic Group (212417) - 31" Model

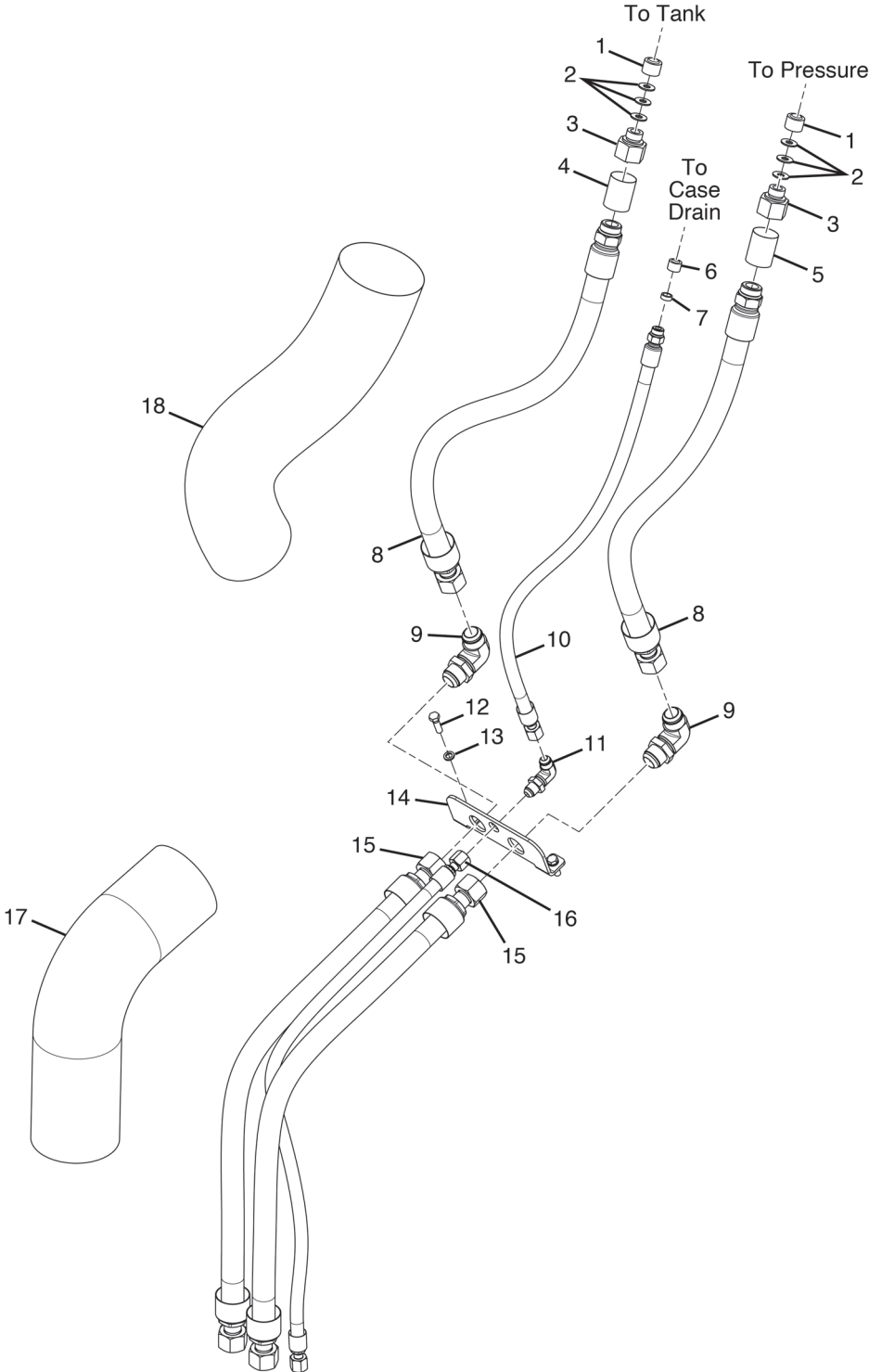

Parts Identification

Hydraulic Group (212417) - 31" Model

#	QTY.	PART #	DESCRIPTION
1	2	N15893	CAP, 3/4 ALUMINUM HOSE
2	6	4064	WASHER, FLAT 3/8"
3	2	N28108	ADAPTER, - 12MOR - 16FOR
4	1	N24823	DECAL, RETURN
5	1	N24822	DECAL, PRESSURE
6	1	N15895	CAP, 1/2 ALUMINUM HOSE
7	1	N32002	PLUG, 3/8 SCH 40 X .25
8	2	N38496	HOSE, 1 X 78 -16FJIC -16MORB
9	2	N157919	ADAPTER, 90 BULKHEAD -16MJIC
10	1	212409	HOSE, 1/2 X 78 -8FJIC -8MORB
11	1	N28885	ADAPTER, 90 BULKHEAD -8MJIC
12	2	4005	BOLT, 3/8" X 1-1/4" GRADE 5
13	2	N16470	WASHER, 3/8 NORDLOCK
14	1	212419	PLATE, BULKHEAD HOLDER 31
15	2	212422	HOSE, 1 X 39 -16FJIC -16FJIC
16	1	212424	HOSE, 1/2 X 40 -8FJIC -8FJIC
17	1	212719	WRAP, HOSE 22
18	1	N88334	WRAP, HOSE 70

Parts Identification

Wheel, 24 Phantom Stump Grind Leonardi (209966)

* For parts breakdown of item 2 - Teeth Kit L/R (209530), see page 42.

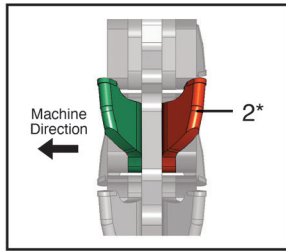

** For parts breakdown of item 3 - Teeth Kit 2/S (209531), see page 42.

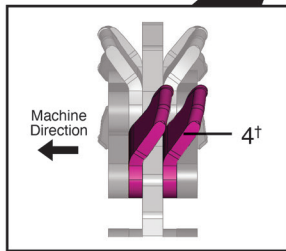
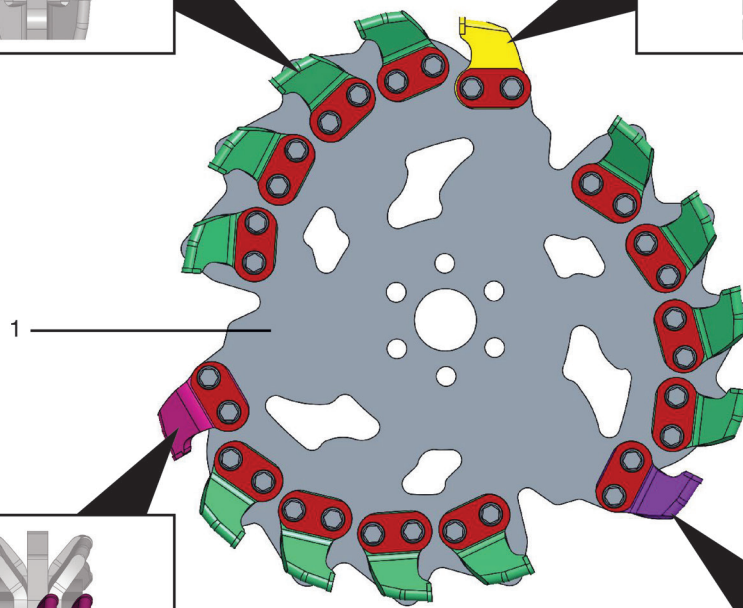
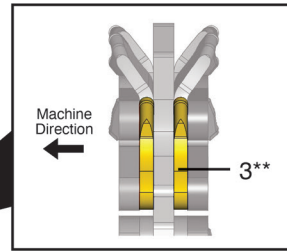

† For parts breakdown of item 4 - Teeth Kit 2/L (209532), see page 43.

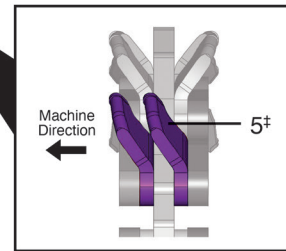

‡ For parts breakdown of item 5 - Teeth Kit 2/R (209533), see page 43.

#	QTY.	PART #	DESCRIPTION
1	1	212121	PLATE, GRINDER WHEEL DISC 24
2	12	209530	KIT, TOMAHAWK GRINDER TEETH L/R
3	1	209531	KIT, TOMAHAWK GRINDER TEETH 2/S
4	1	209532	KIT, TOMAHAWK GRINDER TEETH 2/L
5	1	209533	KIT, TOMAHAWK GRINDER TEETH 2/R

Wheel, 31 Phantom Stump Grind Leonardi (209433)

** For parts breakdown of item 3 - Teeth Kit 2/S (209531), see page 42.

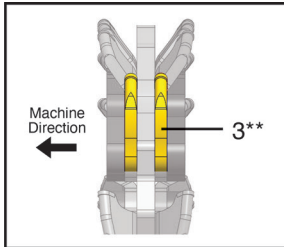

‡ For parts breakdown of item 5 - Teeth Kit 2/R (209533), see page 43.

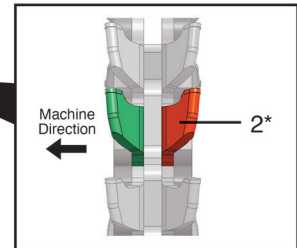
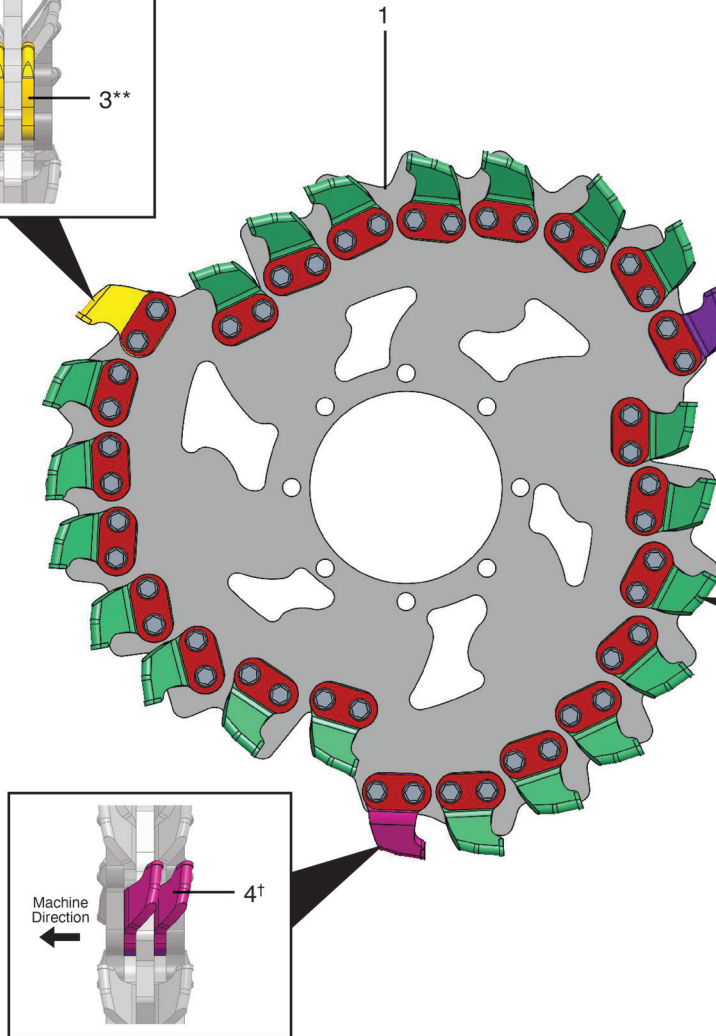
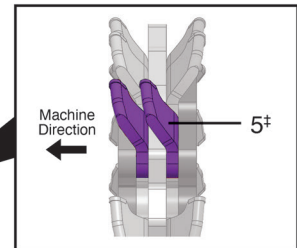

* For parts breakdown of item 2 - Teeth Kit L/R (209530), see page 42.

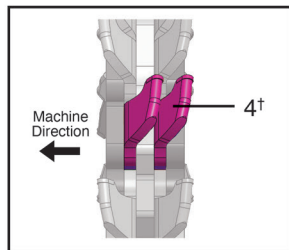

† For parts breakdown of item 4 - Teeth Kit 2/L (209532), see page 43.

#	QTY.	PART #	DESCRIPTION
1	1	209529	PLATE, GRINDER WHEEL DISC
2	21	209530	KIT, TOMAHAWK GRINDER TEETH L/R
3	1	209531	KIT, TOMAHAWK GRINDER TEETH 2/S
4	1	209532	KIT, TOMAHAWK GRINDER TEETH 2/L
5	1	209533	KIT, TOMAHAWK GRINDER TEETH 2/R

Parts Identification

Kit, Tomahawk Grinder Teeth L/R Leonardi (209530)

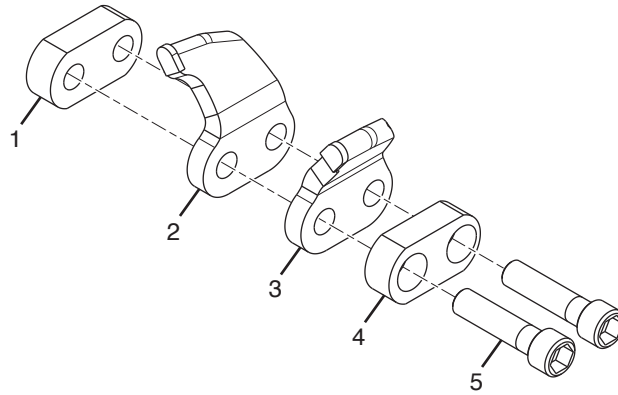

#	QTY.	PART #	DESCRIPTION
1	1	209538	BLOCK, MOUNTING THREADED
2	1	209534	TOOTH, TOMAHAWK GRINDER LEFT
3	1	209535	TOOTH, TOMAHAWK GRINDER RIGHT
4	1	209539	BLOCK, MOUNTING COUNTERBORE
5	2	212445	SCREW, 5/8-18UNF X 2-1/2" GR 8

Kit, Tomahawk Grinder Teeth 2/S Leonardi (209531)

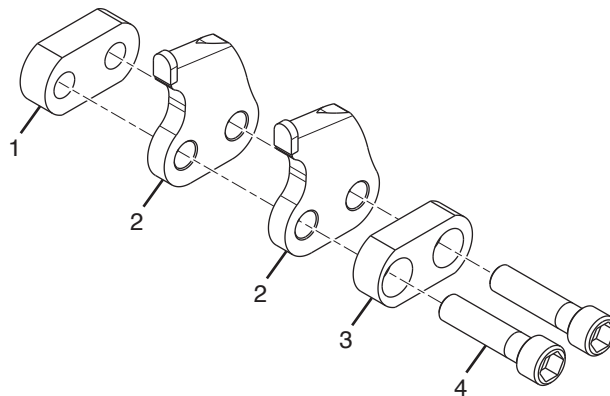

#	QTY.	PART #	DESCRIPTION
1	1	209538	BLOCK, MOUNTING THREADED
2	2	209536	TOOTH, TOMAHAWK GRINDER STRAIGHT
3	1	209539	BLOCK, MOUNTING COUNTERBORE
4	2	212445	SCREW, 5/8-18UNF X 2-1/2" GR 8

Kit, Tomahawk Grinder Teeth 2/L Leonardi (209532)

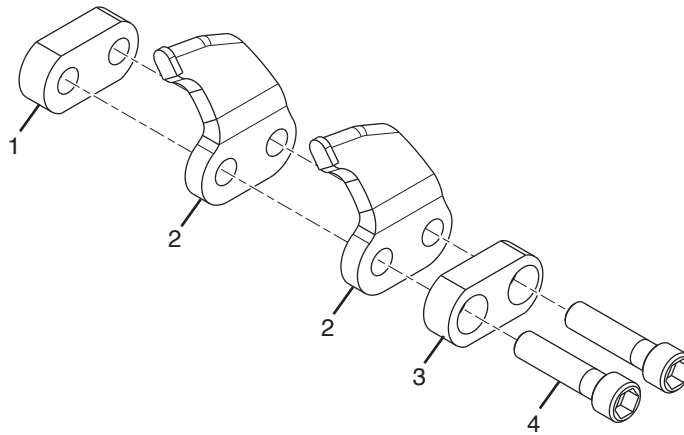

#	QTY.	PART #	DESCRIPTION
1	1	209538	BLOCK, MOUNTING THREADED
2	2	209534	TOOTH, TOMAHAWK GRINDER LEFT
3	1	209539	BLOCK, MOUNTING COUNTERBORE
4	2	212445	SCREW, 5/8-18UNF X 2-1/2" GR 8

Kit, Tomahawk Grinder Teeth 2/R Leonardi (209533)

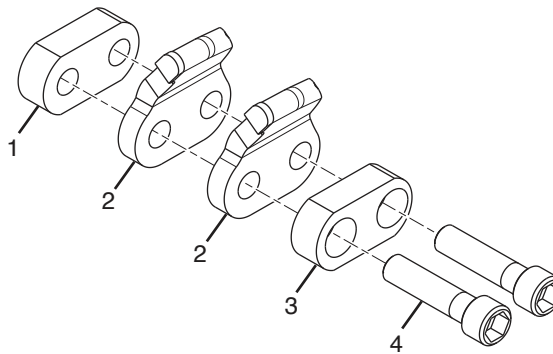

#	QTY.	PART #	DESCRIPTION
1	1	209538	BLOCK, MOUNTING THREADED
2	2	209535	TOOTH, TOMAHAWK GRINDER RIGHT
3	1	209539	BLOCK, MOUNTING COUNTERBORE
4	2	212445	SCREW, 5/8-18UNF X 2-1/2" GR 8

Parts Identification

SAI Motor (209967) - 24" Model

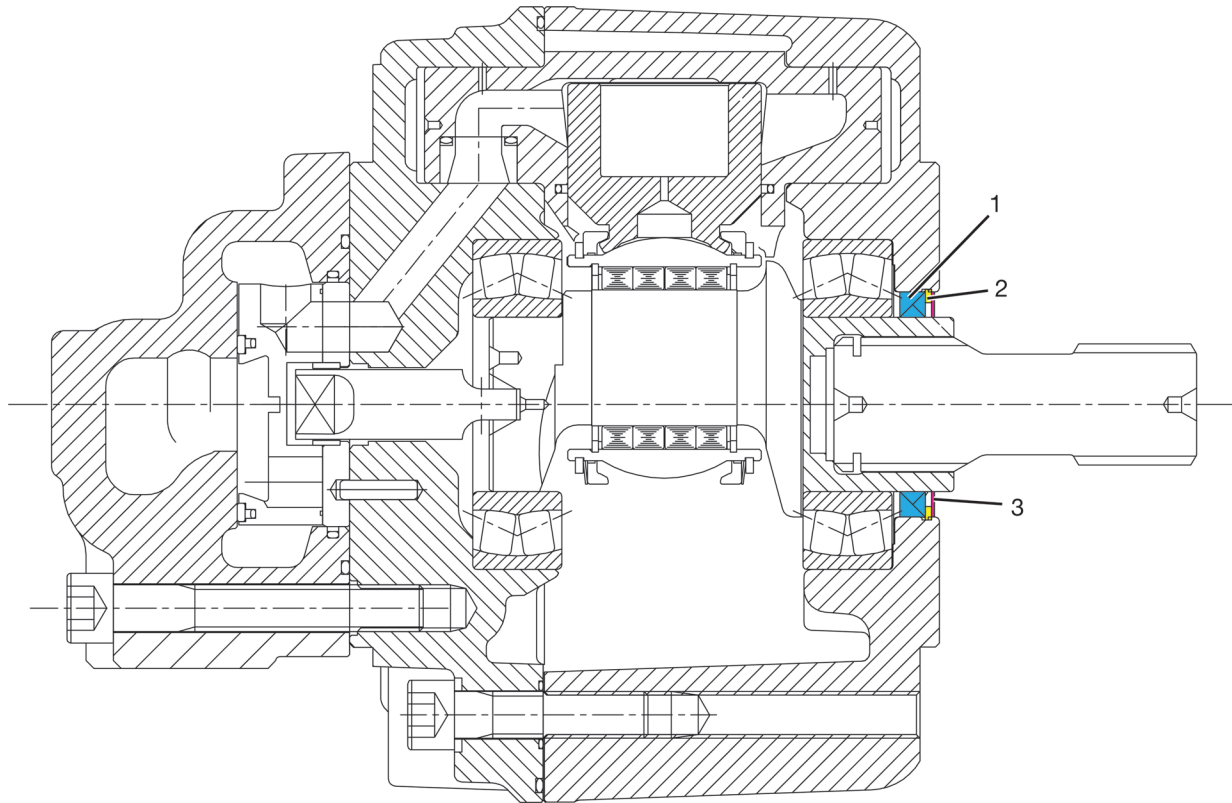

#	QTY.	PART #	DESCRIPTION
*	1	212720	KIT, FS15A1/A2 MOTOR SEAL (Includes items 1, 2 and 3)
1	1	NOT SOLD SEPARATELY	SEAL, SHAFT
2	1	NOT SOLD SEPARATELY	RING, RETAINING SB60
3	1	NOT SOLD SEPARATELY	RING, HIGH PRESSURE BACKUP

Seal, SAI Bearing Support Shaft (212129) - 24" Model

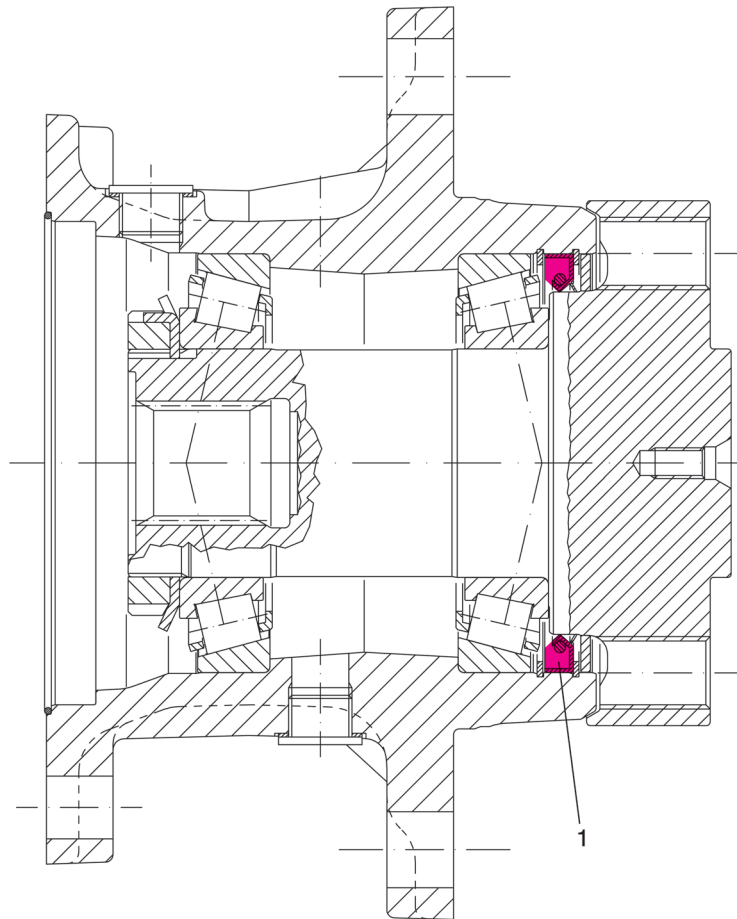

#	QTY.	PART #	DESCRIPTION
1	1	212129	SEAL, SAI BEARNG SUPPORT SHAFT

Parts Identification

SAI Motor (209576) - 31" Model

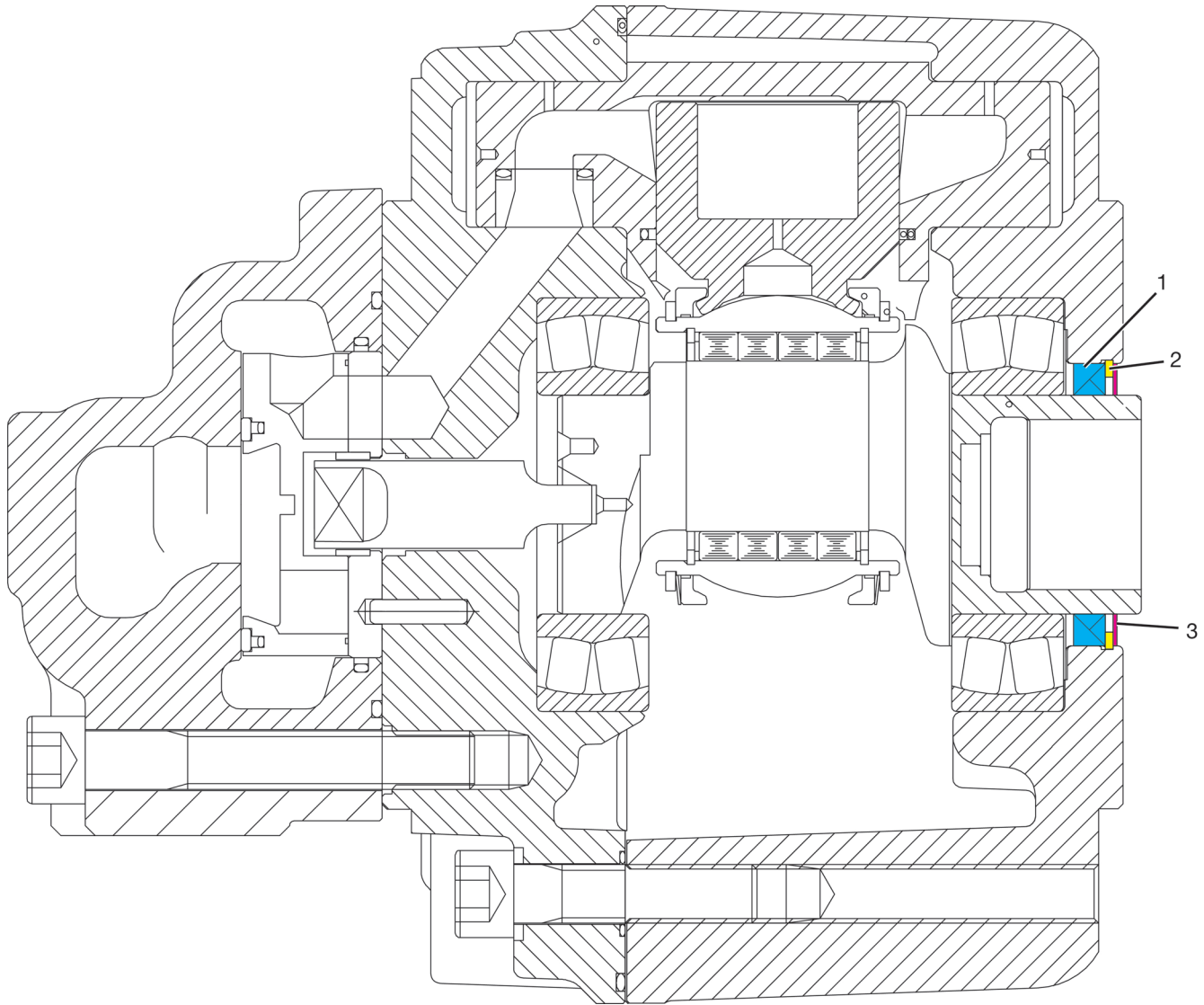

#	QTY.	PART #	DESCRIPTION
*	1	206999	KIT, FS30A1/A2 MOTOR SEAL (Includes items 1, 2 and 3)
1	1	NOT SOLD SEPARATELY	SEAL, SHAFT
2	1	NOT SOLD SEPARATELY	RING, RETAINING SB70
3	1	NOT SOLD SEPARATELY	RING, HIGH PRESSURE BACKUP

Seal, SAI Bearing Support Shaft (212126) - 31" Model

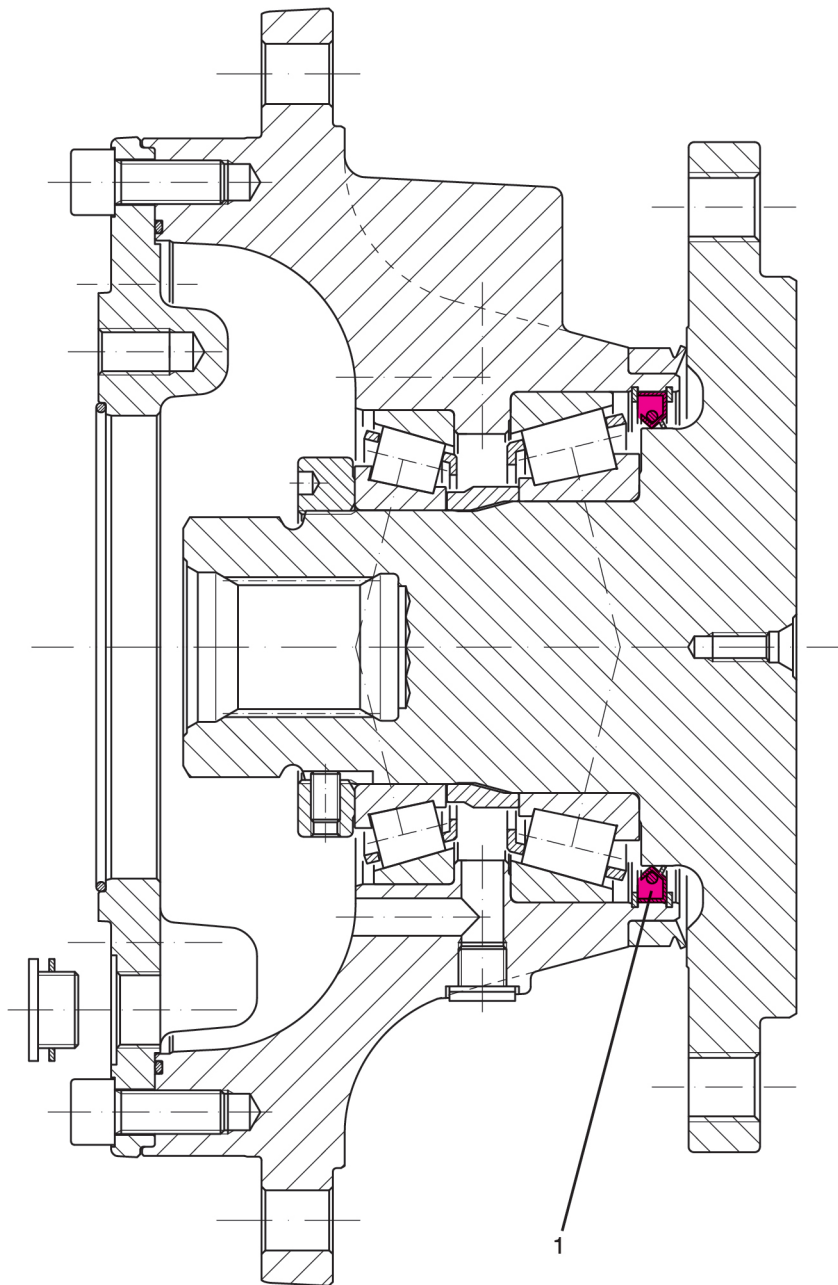

#	QTY.	PART #	DESCRIPTION
1	1	212126	SEAL, SAI BEARNG SUPPORT SHAFT

Parts Identification

Machine Decals and Signs

NOTE: All safety related decals are also shown in the Safety Instructions Section along with their location on the machine. See "Safety Decal Locations" on page 10.

Check and replace any worn, torn, hard to read or missing decals on your machine.

Part No. 209849



Part No. 200491



Part No. N23506



Part No. 4334



Part No. N68716



Part No. N28386



Part No. N17013

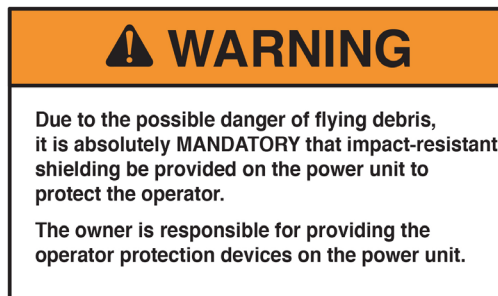

Part No. 203264



Machine Decals and Signs (Cont'd)

Part No. 207851



Part No. 212400 - 24" Model



Part No. N13721



Part No. 212020 - 31" Model



Part No. 209449



Part No. 212135



Part No. N13517



Part No. N26974 (Horizontal Small)





Specifications

DESCRIPTION	STUMP AX	
	24"	31"
Single Pass Cutting Depth	4 in. (10.16 cm) maximum	
Motor	Radial Piston	
Wheel Tip Diameter	24.0 in. (60.96 cm)	31.875 in. (80.96 cm)
Mount	Universal Skid Loader; Custom Excavator	
Blade	Fixed	
Teeth	14 Left Cutting Teeth, 14 Right Cutting Teeth, 2 Straight Cutting Teeth	23 Left Cutting Teeth, 23 Right Cutting Teeth, 2 Straight Cutting Teeth
Deflector	Outfeed, Chains	

Appendix

Dimensions - 24" Stump Ax

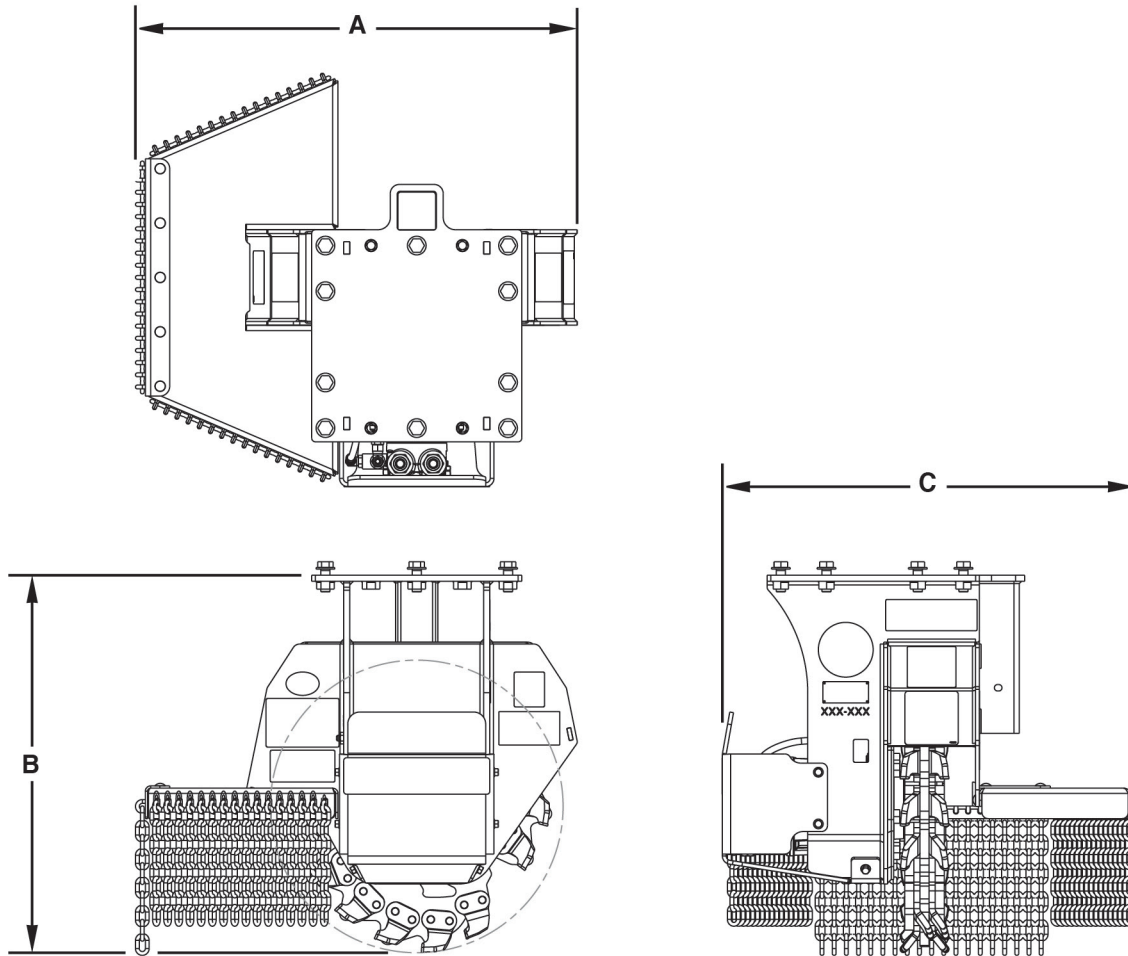

DESCRIPTION	24" STUMP AX
Stump Ax Width (A)	36.3 in. (127.0 cm)
Stump Ax Height (B)	31.0 in. (86.1 cm)
Stump Ax Length (C)	33.9 in. (88.4 cm)
Weight (Base Unit/No Mount)	575 lbs. (261 kg)
Weight (with Skid Loader Mount)	1,010 lbs. (459 kg)

Dimensions - 31" Stump Ax

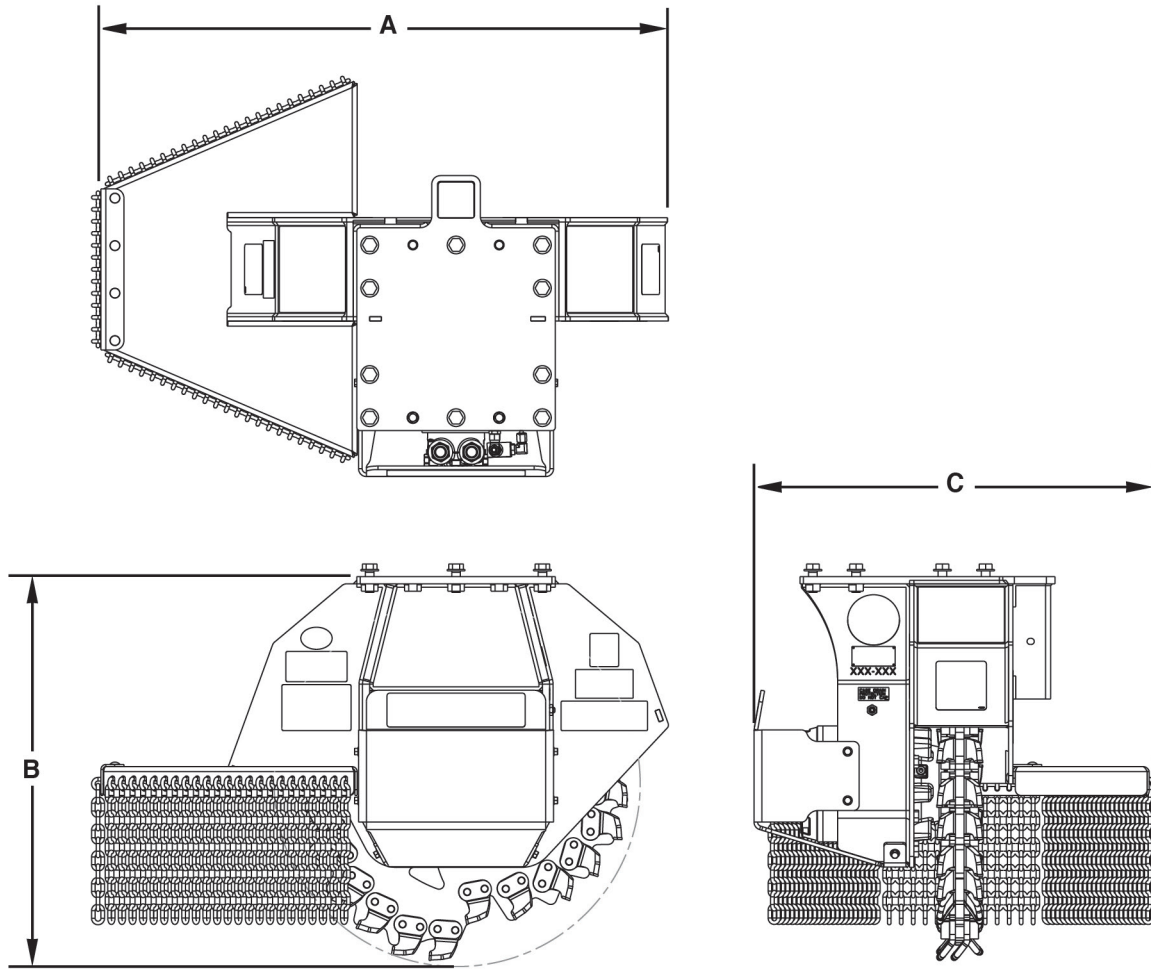

DESCRIPTION	31" STUMP AX
Stump Ax Width (A)	50.0 in. (127.0 cm)
Stump Ax Height (B)	33.9 in. (86.1 cm)
Stump Ax Length (C)	34.8 in. (88.4 cm)
Weight (Base Unit/No Mount)	885 lbs. (402 kg)
Weight (with Skid Loader Mount)	1,320 lbs. (599 kg)

Appendix

Torque Specifications

Inches Hardware and Lock Nuts

TORQUE CHARTS Minimum Hardware Tightening Torques

Normal Assembly Applications
(Standard Hardware and Lock Nuts)

SAE Gr. 2 Nominal Size	SAE Grade 5		SAE Grade 8		LOCK NUTS			
	Unplated or Plated Silver	Plated W / ZnCr Gold	Unplated or Plated Silver	Plated W / ZnCr Gold	Unplated or Plated Silver	Plated W / ZnCr Gold	Grade W / Gr. 5 Bolt	Grade W / Gr. 8 Bolt
1/4	55 in.-lb. (6.2 N•m)	72 in.-lb. (8.1 N•m)	86 in.-lb. (9.7 N•m)	112 in.-lb. (12.6 N•m)	121 in.-lb. (13.6 N•m)	157 in.-lb. (17.7 N•m)	61 in.-lb. (6.9 N•m)	86 in.-lb. (9.8 N•m)
5/16	115 in.-lb. (13 N•m)	149 in.-lb. (17 N•m)	178 in.-lb. (20 N•m)	229 in.-lb. (26 N•m)	250 in.-lb. (28 N•m)	324 in.-lb. (37 N•m)	125 in.-lb. (14 N•m)	176 in.-lb. (20 N•m)
3/8	17 ft.-lb. (23 N•m)	22 ft.-lb. (30 N•m)	26 ft.-lb. (35 N•m)	34 ft.-lb. (46 N•m)	37 ft.-lb. (50 N•m)	48 ft.-lb. (65 N•m)	19 ft.-lb. (26 N•m)	26 ft.-lb. (35 N•m)
7/16	27 ft.-lb. (37 N•m)	35 ft.-lb. (47 N•m)	42 ft.-lb. (57 N•m)	54 ft.-lb. (73 N•m)	59 ft.-lb. (80 N•m)	77 ft.-lb. (104 N•m)	30 ft.-lb. (41 N•m)	42 ft.-lb. (57 N•m)
1/2	42 ft.-lb. (57 N•m)	54 ft.-lb. (73 N•m)	64 ft.-lb. (87 N•m)	83 ft.-lb. (113 N•m)	91 ft.-lb. (123 N•m)	117 ft.-lb. (159 N•m)	45 ft.-lb. (61 N•m)	64 ft.-lb. (88 N•m)
9/16	60 ft.-lb. (81 N•m)	77 ft.-lb. (104 N•m)	92 ft.-lb. (125 N•m)	120 ft.-lb. (163 N•m)	130 ft.-lb. (176 N•m)	169 ft.-lb. (229 N•m)	65 ft.-lb. (88 N•m)	92 ft.-lb. (125 N•m)
5/8	83 ft.-lb. (112 N•m)	107 ft.-lb. (145 N•m)	128 ft.-lb. (174 N•m)	165 ft.-lb. (224 N•m)	180 ft.-lb. (244 N•m)	233 ft.-lb. (316 N•m)	90 ft.-lb. (122 N•m)	127 ft.-lb. (172 N•m)
3/4	146 ft.-lb. (198 N•m)	189 ft.-lb. (256 N•m)	226 ft.-lb. (306 N•m)	293 ft.-lb. (397 N•m)	319 ft.-lb. (432 N•m)	413 ft.-lb. (560 N•m)	160 ft.-lb. (217 N•m)	226 ft.-lb. (306 N•m)
7/8	142 ft.-lb. (193 N•m)	183 ft.-lb. (248 N•m)	365 ft.-lb. (495 N•m)	473 ft.-lb. (641 N•m)	515 ft.-lb. (698 N•m)	667 ft.-lb. (904 N•m)	258 ft.-lb. (350 N•m)	364 ft.-lb. (494 N•m)
1	213 ft.-lb. (289 N•m)	275 ft.-lb. (373 N•m)	547 ft.-lb. (742 N•m)	708 ft.-lb. (960 N•m)	773 ft.-lb. (1048 N•m)	1000 ft.-lb. (1356 N•m)	386 ft.-lb. (523 N•m)	545 ft.-lb. (739 N•m)

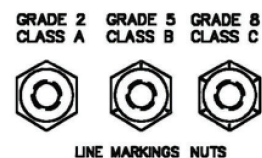
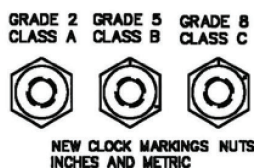
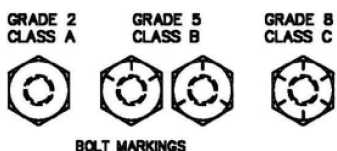

CENTER LOCK MARKING



LOCK NUT MARKING



LOCK NUT NOTCH MARKING



LOCK NUT LETTER MARKING

Torque Specifications (Cont'd)

Metric Hardware and Lock Nuts

TORQUE CHARTS
 Minimum Hardware Tightening Torques
 Normal Assembly Applications
 (Metric Hardware and Lock Nuts)

Nominal Size	Class 5,8		Class 8,8		Class 10,9		Lock nuts
	Unplated or Plated Silver	Plated W / ZnCr Gold	Unplated or Plated Silver	Plated W / ZnCr Gold	Unplated or Plated Silver	Plated W / ZnCr Gold	Class 8 W / CL. 8,8 Bolt
M4	1.7 N•m (15 in.-lb.)	2.2 N•m (19 in.-lb.)	2.6 N•m (23 in.-lb.)	3.4 N•m (30 in.-lb.)	3.7 N•m (33 in.-lb.)	4.8 N•m (42 in.-lb.)	1.8 N•m (16 in.-lb.)
M6	5.8 N•m (51 in.-lb.)	7.6 N•m (67 in.-lb.)	8.9 N•m (79 in.-lb.)	12 N•m (102 in.-lb.)	13 N•m (115 in.-lb.)	17 N•m (150 in.-lb.)	6.3 N•m (56 in.-lb.)
M8	14 N•m (124 in.-lb.)	18 N•m (159 in.-lb.)	22 N•m (195 in.-lb.)	28 N•m (248 in.-lb.)	31 N•m (274 in.-lb.)	40 N•m (354 in.-lb.)	15 N•m (133 in.-lb.)
M10	28 N•m (21 ft.-lb.)	36 N•m (27 ft.-lb.)	43 N•m (32 ft.-lb.)	56 N•m (41 ft.-lb.)	61 N•m (45 ft.-lb.)	79 N•m (58 ft.-lb.)	30 N•m (22 ft.-lb.)
M12	49 N•m (36 ft.-lb.)	63 N•m (46 ft.-lb.)	75 N•m (55 ft.-lb.)	97 N•m (72 ft.-lb.)	107 N•m (79 ft.-lb.)	138 N•m (102 ft.-lb.)	53 N•m (39 ft.-lb.)
M16	121 N•m (89 ft.-lb.)	158 N•m (117 ft.-lb.)	186 N•m (137 ft.-lb.)	240 N•m (177 ft.-lb.)	266 N•m (196 ft.-lb.)	344 N•m (254 ft.-lb.)	131 N•m (97 ft.-lb.)
M20	237 N•m (175 ft.-lb.)	307 N•m (226 ft.-lb.)	375 N•m (277 ft.-lb.)	485 N•m (358 ft.-lb.)	519 N•m (383 ft.-lb.)	671 N•m (495 ft.-lb.)	265 N•m (195 ft.-lb.)
M24	411 N•m (303 ft.-lb.)	531 N•m (392 ft.-lb.)	648 N•m (478 ft.-lb.)	839 N•m (619 ft.-lb.)	897 N•m (662 ft.-lb.)	1160 N•m (855 ft.-lb.)	458 N•m (338 ft.-lb.)

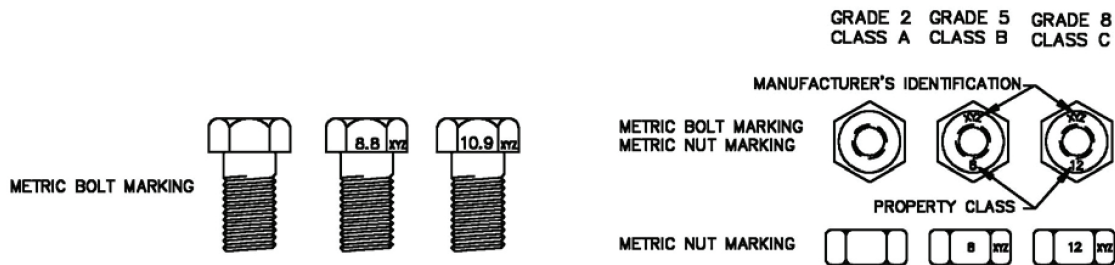



www.loftness.com

Loftness Specialized Equipment, Inc.
650 So. Main Street • PO Box 337 • Hector, MN 55342
Tel: 320.848.6266 • Fax: 320.848.6269 • Toll Free: 1.800.828.7624

Printed in USA
© Loftness 2024