



Battle Ax Skid Loader

Skid Loader Mulching Head

61 • 71

Owner's Manual and Parts Book
(Originating with Serial Number 84-2081)



Model Number: _____
Serial Number: _____
Date of Purchase: _____

LOFTNESS ™

LOFTNESS SPECIALIZED EQUIPMENT, INC.

LIMITED WARRANTY POLICY

The limited warranty policy begins upon delivery of the unit to the original customers.

The following Loftness products have a two (2) year limited warranty;

XLB10 Grain Bag Loader, Battle Ax L-series Skid Steer, Battle Ax S-series Skid Steer, Battle Ax H-series Skid Steer, Battle Ax Excavator 20-series, Battle Ax Excavator 30-series, Battle Ax Excavator 40-series, Battle Ax Excavator 50-series, Battle Ax Extreme, Bad Ax Skid Steer, Timber Ax Skid Steer, Stump Ax, BT20, Kwik Cut.

All other Loftness products have a one (1) year limited warranty.

If any Loftness product is used as rental or leased equipment the limited warranty period is for only 30 days from the delivery date to the original customers.

Loftness Specialized Equipment, hereinafter referred to as LOFTNESS, a manufacturer of quality machinery since 1956, warrants new LOFTNESS machinery and/or attachments at the time of delivery to the original purchaser, to be free from defects in material and workmanship when properly set up and operated in accordance with the recommendations set forth in the LOFTNESS Operator's Manual.

LOFTNESS' liability for any defect with respect to accepted goods shall be limited to repairing the goods at an authorized dealer or other LOFTNESS designated location, or replacing them as LOFTNESS shall elect. The above shall be in accordance with LOFTNESS warranty adjustment policies.

WARRANTY REQUIREMENTS

Warranty registration form must be filled out and returned to Loftness Specialized Equipment to validate all warranty claims.

To receive a warranty claim, a return authorization from LOFTNESS must be obtained. The failed part may then be returned in an untampered status. This warranty does not include freight or delivery charges incurred when returning machinery for servicing. Dealer mileage, service calls and pick-up/delivery charges are the customer's responsibility.

LIMITATIONS OF WARRANTY

LOFTNESS products are designed to provide years of dependable service when proper use and maintenance is adhered to. The potential for misuse in many applications exists; therefore, a limited warranty is provided as follows.

This warranty shall not apply to any machine or attachment which shall have been repaired or altered outside the LOFTNESS factory or authorized LOFTNESS dealership or in any way so as in LOFTNESS' judgment, to affect its stability or reliability, nor which has been subject to misuse, negligence or accident, nor to any machine or attachment which shall not have been operated in accordance with LOFTNESS' printed instructions or beyond the company recommended machine rated capacity. LOFTNESS may elect to have an area representative evaluate the condition of the machine before warranty is considered.

In addition, this limited warranty provides no coverage for general wear or maintenance items, misuse, environmental conditions and/or contamination for which they were not designed or not intended, including but not limited to the following items;

Use of machine beyond its rated capacity, Conveyors, Improper knife replacement, Auger wear, Missing knives, Saw blades, Striking foreign objects, Brakes and brake pads, Lack of lubrication, Tires, Failures caused by running in an "out-of-balance" condition, Hydraulic hoses damaged by being caught in "pinch points" or by moving parts, and Damage caused by excessive force from the power unit.

EXCLUSIONS OF WARRANTY

Except as otherwise expressly stated herein, LOFTNESS makes no representation or warranty of any kind, expressed or implied. **The implied warranty of merchantability and fitness for a particular purpose are excluded from this limited warranty.** The remedies set forth in this warranty are the only remedies available to any person under this warranty. LOFTNESS shall have no liability to any person for incidental, consequential or special damages of any description, whether arising out of express or implied warranty or any other contract, negligence, or other tort or otherwise. This exclusion of consequential, incidental and special damages is independent from and shall survive any finding that the exclusive remedy failed of its essential purpose. Upon purchase, the buyer assumes all liability, all personal injury and property damage resulting from the handling, possession or use of the goods by the buyer.

No agent, employee or representative of LOFTNESS has any authority to bind LOFTNESS to any affirmation, representation or warranty concerning its machinery and/or attachments except as specifically set forth herein. (August 2023)

LOFTNESS ™



To the Dealer:

In order to ensure compatibility / performance of the Loftness attachment and the customer’s power unit, it is IMPERATIVE that this Pre-Delivery Inspection (“PDI”) be completed using the customer’s actual power unit.

PRE-DELIVERY INSPECTION

Dealer: By initialing each line I understand and promise that I have completed the following:

- ___ Verified the attachment is set up properly for customers power unit. (check model code with manual)
- ___ Greased all grease zerks till grease purges out of bearing.
- ___ Removed all shipping brackets.
- ___ Adjusted push bar out of shipping position. (if equipped) (full forward position recommended)
- ___ Installed head on customer’s unit that will be running the attachment and set hydraulic flow per power unit manufacturer owner’s manual for preferred flow.
- ___ Recorded the Serial Number / Make / Model of the power unit.
Power unit. S/N _____ Make _____ Model _____ GPM _____
- ___ Recorded the Serial Number and Model of the Loftness attachment. S/N _____ Model _____
- ___ Verified power unit manufacturer outlined Auxiliary coupler orientation for pressure, return & case drain line.
- ___ Verified/recorded rotor RPM at full throttle per model & chart in Loftness owner’s manual. RPM _____
- ___ Performed an Auxiliary system pressure stall check on the power unit only and verified that max pressure rating is achieved per power unit manufacturer specifications. Recorded pressure observed _____ PSI

PDI completed by: _____ Print

Signed/Date

Contact Loftness factory if any of the tests are not within power unit or Loftness specifications.

DELIVERY

- ___ Showed customer all grease zerks.
- ___ Showed customer adjustable push bar options. (if equipped)
- ___ Showed customer how to properly engage hydraulics to operate attachment.
- ___ Reviewed owner’s manual, all on-product warnings and instructions, and safe operation with customer.
- ___ Assisted customer with completing / submitting Warranty Registration Form to Loftness by one of the below options.

Dealer also needs to submit a copy of this completed PDI to Loftness and maintain the copy in owner’s manual for unit.

Mail to:

Loftness Specialized Equipment
PO Box 337
Hector, MN 55342

Delivered to Customer by: _____ **Print**

Signed/Date

Email to: registration@loftness.com

LOFTNESS COPY



To the Dealer:

In order to ensure compatibility / performance of the Loftness attachment and the customer’s power unit, it is IMPERATIVE that this Pre-Delivery Inspection (“PDI”) be completed using the customer’s actual power unit.

PRE-DELIVERY INSPECTION

Dealer: By initialing each line I understand and promise that I have completed the following:

- ___ Verified the attachment is set up properly for customers power unit. (check model code with manual)
- ___ Greased all grease zerks till grease purges out of bearing.
- ___ Removed all shipping brackets.
- ___ Adjusted push bar out of shipping position. (if equipped) (full forward position recommended)
- ___ Installed head on customer’s unit that will be running the attachment and set hydraulic flow per power unit manufacturer owner’s manual for preferred flow.
- ___ Recorded the Serial Number / Make / Model of the power unit.
Power unit. S/N _____ Make _____ Model _____ GPM _____
- ___ Recorded the Serial Number and Model of the Loftness attachment. S/N _____ Model _____
- ___ Verified power unit manufacturer outlined Auxiliary coupler orientation for pressure, return & case drain line.
- ___ Verified/recorded rotor RPM at full throttle per model & chart in Loftness owner’s manual. RPM _____
- ___ Performed an Auxiliary system pressure stall check on the power unit only and verified that max pressure rating is achieved per power unit manufacturer specifications. Recorded pressure observed _____ PSI

PDI completed by: _____ Print

Signed/Date

Contact Loftness factory if any of the tests are not within power unit or Loftness specifications.

DELIVERY

- ___ Showed customer all grease zerks.
- ___ Showed customer adjustable push bar options. (if equipped)
- ___ Showed customer how to properly engage hydraulics to operate attachment.
- ___ Reviewed owner’s manual, all on-product warnings and instructions, and safe operation with customer.
- ___ Assisted customer with completing / submitting Warranty Registration Form to Loftness by one of the below options.
Dealer also needs to submit a copy of this completed PDI to Loftness and maintain the copy in owner’s manual for unit.

Mail to:
Loftness Specialized Equipment
PO Box 337
Hector, MN 55342

Delivered to Customer by: _____ Print

Signed/Date

Email to: registration@loftness.com

CUSTOMER COPY

LOFTNESS ™

Table of Contents

Warranty

Table of Contents

Ordering Code

Ordering Code	1
Battle Ax Skid Loader (Example)	1

Introduction

Owner Information	3
Warranty Policy	3
Serial Number Location	3
Owner's Manual Access	3
Battle Ax Features	4

Safety Instructions

Safety First	5
Owner's Responsibility	5
Mandatory Shut-Down Procedure	6
Safety Rules	6
Hydraulic Safety	7
California Proposition 65 Warning	7
Battle Ax Skid Loader Identification	8
Safety Decal Locations	9

Set-up Instructions

Pusher Bar Assembly	13
Removing Shipping Stands	14
Installing the Battle Ax to the Loader	14
Hydraulic Connections	15
Checking Rotor Rotation	15
Checking Rotor Speed	16
Cutter Bar Adjustment/Removal	16

Operating Instructions

Getting Started	17
Operation	17
Clearing Jams	18
Log Moving	18
Hydraulic Hose Storage	18

Maintenance

General Maintenance	19
Maintenance Schedule	19
Lubrication	19
Grease Points Location	19
Overhung Load Adapter	20
Removing Belt Cover	21

Table of Contents

Tooth Removal and Installation	24
Maintenance (Cont'd)	
Removing Rotor Bearing Cover and Valve Access Cover	21
Removing Motor Cover	22
Skid Removal/Replacement	22
Belt Tension Adjustment	23
Replacing Belt	23
Sprocket Removal	23
Tooth Removal and Installation	24
Quadco Teeth	24
Tooth Sharpening (Quadco)	25
Recutter Removal/Replacement	26
Installing/Removing the Hood Liner	26
Clearing the Cutter Bar	26
For a new or unused machine:	26
For a machine that has already been used or put into service:	26
Mounting the Hood Liner	27
Retightening/Reinstalling the Cutter Bar and Recutter	27
Storage	28
End of Season	28
Beginning of the Season	28
Motor & Sprocket Selection Chart	29
Variable Displacement Motor (Parker)	29
Standard Speed	29
High Speed	30
Loader Hydraulic System Pressure Chart	31
Fixed Displacement Motor (Muncie)	31
Troubleshooting	32
Parts Identification	
Battle Ax S Series Covers and Skids	34
Shield, Motor (209519)	36
Battle Ax S Series Deflector Chains, Stands, and Belt Adjustment	37
Battle Ax S Series Cutter and Re-Cutter Bars	38
Pusher	39
Belt and Sprocket Options	40
Belt Assembly, 50T 35B 37MM 1568 - Code "T" (203173)	41
Belt Assembly, 48T 38B 37MM 1568 - Code "A" (N80411)	42
Belt Assembly, 45T 40B 37MM 1568 - Code "B" (N80392)	43
Belt Assembly, 45T 43B 37MM 1568 - Code "D" (N132294)	44
Belt Assembly, 43T 45B 37MM 1568 - Code "H" (208314)	45
Belt Assembly, 40T 45B 37MM 1568 - Code "I" (208315)	46
Belt Assembly, 40T 48B 37MM 1568 - Code "J" (208316)	47
Belt Assembly, 48T 37B 37MM 1568 - Code "U" (203174)	48
Belt Assembly, 48T 40B 37MM 1568 - Code "V" (203175)	49
Belt Assembly, 40T 36B 20MM 1400 - Code "E" (N132298)	50

Table of Contents

Parts Identification (Cont'd)

Gauge, Pressure	53
Hydraulics, Parker Motor No Brake (209063)	54
Hydraulics, Parker Motor No Brake (209063) (Cont'd)	56
Hydraulics, Parker Motor Closed Loop Flushing (209062)	58
Hydraulics, Parker Motor Closed Loop Flushing (209062) (Cont'd)	60
Hydraulics, Muncie Fixed-Displacement Motor (209061)	62
Hydraulics, Muncie Fixed-Displacement Motor (209061) (Cont'd)	64
Valve, Cross Port Relief (N34677)	66
Manifold, Relief 5000 PSI, Check (200655)	66
Manifold, Closed Loop Flushing (200699)	67
Hydraulic Motor, Variable 90cc to 110cc (207679)	68
Overhung Load Adapter (N51193)	69
Hydraulic Motor, 62.9cc (N34676)	70
Overhung Load Adapter (N16416)	71
Rotor Assembly, 206983 - 61" Rotor With Carbide Cutter; 206981 - 61" Rotor With Quadco Cutter; 206982 - 61" Rotor With Quadco Hard Surface Cutter; 206986 - 71" Rotor With Carbide Cutter; 206984 - 71" Rotor With Quadco Cutter; 206985 - 71" Rotor With Quadco Hard Surface Cutter	72
Rotor, Bolt-in Bulkhead with Double Carbide Teeth - 61" (202529), 71" (202536)	74
Rotor, Bolt-in Bulkhead with Quadco Teeth - 61" (202524), 71" (202531)	75
Rotor, Bolt-in Bulkhead with Quadco Hard Surface Teeth - 61" (202527), 71" (202534)	76
Lubrication	77
Machine Decals and Signs	78

Options

Kit, Right Hand Hose Conversion - 4,000 PSI (209065)	81
Kit, Right Hand Hose Conversion - 6,000 PSI (209064)	82
Liner, Bolt-in - 61" (209043), 71" (209044)	83

Appendix

Specifications	85
Dimensions	86
Torque Specifications	87
Inches Hardware and Lock Nuts	87
Metric Hardware and Lock Nuts	88



Ordering Code

Battle Ax Skid Loader (Example)

The ordering code will consist of two numbers (machine size), two letters (machine type), one letter (tooth type), two numbers (motor system), one letter (sprocket/belt combo), one number (threshold setting), and one letter (options). An example for a Battle Ax of this type would be as shown below.

61BSS44T1.F

SIZE

61 = 61" Cut
71 = 71" Cut

TYPE

BS = Battle Ax Skid Loader

TOOTH

Q = Quadco Planer
H = Hard Surface
S = Standard Double Carbide

MOTOR SYSTEM

38 = Muncie Fixed Displacement
44 = Parker Variable Displacement Without Brake
45 = Parker Variable Displacement Closed Loop Flushing

SPROCKET / BELT COMBO

T = 50/35 37MM 1568 - Standard Speed
A = 48/38 37MM 1568 - Standard Speed
B = 45/40 37MM 1568 - Standard Speed
D = 45/43 37MM 1568 - Standard Speed
H = 43/45 37MM 1568 - Standard Speed
I = 40/45 37MM 1568 - Standard Speed
J = 40/48 37MM 1568 - Standard Speed
T = 50/35 37MM 1568 - High Speed
U = 48/37 37MM 1568 - High Speed
V = 48/40 37MM 1568 - High Speed
D = 45/43 37MM 1568 - High Speed
H = 43/45 37MM 1568 - High Speed
I = 40/45 37MM 1568 - High Speed
E = 40/36 20MM 1400 Not Available Over 85HP
F = 38/38 20MM 1400 Not Available Over 85HP
G = 33/38 20MM 1400 Not Available Over 85HP

THRESHOLD SETTING

0 = Setting
1 = Setting
2 = Setting
3 = Setting
4 = Setting
5 = Setting

OPTION

F = Right Hand Hose Conversion 4000PSI
V = Right Hand Hose Conversion 6000PSI
L = Liner



Owner Information

Thank you for your decision to purchase a Battle Ax skid loader-mounted shredder from Loftness. To ensure maximum performance of your machine, it is mandatory that you thoroughly study the owner's manual and follow its recommendations. Proper operation and maintenance are essential to prevent injury or damage and to maximize machine life.

The Loftness Battle Ax is an effective, reliable machine used for maintaining grass, weeds, brush and trees. Efficiently cuts and mulches up to 6" diameter material. Intermittently cuts larger diameter material. For best results, operate the machine as low to the ground as possible without the teeth striking ground or other obstructions. Lifting or tilting the Battle Ax increases the risk of flying debris. Because of the high speed of the teeth, the life of the teeth will be reduced if it is operated in rocky terrain or in areas where many obstacles are present. Areas to be mowed should be free of debris such as rocks, bottles, large branches etc. The teeth cut and pulverize the grass, weeds and brush. The Battle Ax deposits cut material over the entire width-of cut, which eliminates bunching or windrowing behind the machine.

Operate and maintain this machine in a safe manner and in accordance with all applicable local, state, and federal codes, regulations and/or laws, and in compliance with on-product labeling and these instructions.

Make sure that all personnel have read this owner's manual and thoroughly understand safe and correct operating, installation and maintenance procedures.

Continuous improvement and advancement of Loftness products may result in changes to your equipment that may not be reflected in this publication. Loftness reserves the right to make product improvements to the machine at any time. Although great care has been taken to ensure the accuracy of this publication, Loftness does not assume any liability for errors or omissions.

Warranty Policy

Be sure to read and understand the Warranty Policy at the beginning of this manual. It is also important that you fill out the Warranty Registration form(s) completely with your dealer so as not to void the warranty.

Serial Number Location

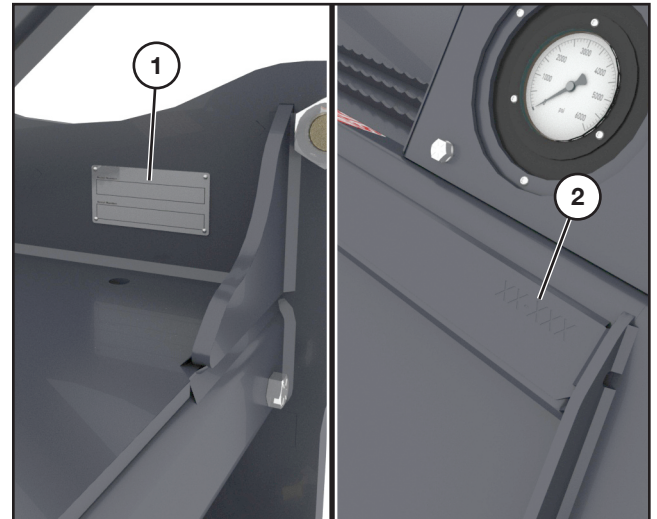

The machine serial number is shown in the tag (1), and is also stamped into the frame (2) on the skid steer mounting bracket.

Always use your model and serial number when requesting information or when ordering parts.

Owner's Manual Access



The Battle Ax is shipped with a printed owner's manual. The manual must be available for all operators. Keep in a safe, dry location.

To access a digital owner's manual, use a smart phone to scan the QR Code (1) located on the motor cover. This code will link to the Battle Ax owner's manual on the Loftness website.

Introduction

Battle Ax Features

- Downward Rotation Design
- Premium Strength Steel Body & Rotor
- Front Mounted
- Hydraulic Driven
- Universal Skid-Loader Mount
- Adjustable Tree Pusher
- Claw Hooks On Tree Pusher
- 17 in. (43 cm) Diameter Rotor (2000 - 2200 RPM)
- 2.1875 in. (56 mm) Piloted Double Taper Roller Bearings
- Anti Wrap Bearing Protection
- Heavy Duty Bearing Block
- Fixed Displacement Gear; or Variable Displacement Piston Type Motor
- Dual Cross-Over Relief Protection
- Pressure Gauge
- Steel Chain Deflectors
- Synchronous Belt
- Tapered-Lock Sprockets
- Hydraulic Hoses
- Adjustable Shear Bar
- Double Carbide; Quadco Planer Teeth (sharpenable); or Hardened Quadco Teeth
- Replaceable Skid Shoes

Safety First



Safety Alert Symbol

This message alert symbol identifies important safety messages on the machine and in the owner's manual. When you see this symbol, be alert to the possibility of personal injury and carefully read the message that follows.

In the owner's manual and on decals used on the machine the words **DANGER, WARNING, CAUTION, IMPORTANT, and NOTE** are used to indicate the following:

DANGER: This word warns of immediate hazards which, if not avoided, will result in severe personal injury or death. The color associated with Danger is RED.



WARNING: This word refers to a potentially hazardous situation which, if not avoided, could result in severe personal injury or death. The color associated with Warning is ORANGE.

CAUTION: This word refers to a potentially hazardous or unsafe situation that, if not avoided, may result in minor or moderate injury. It may also be used to alert against unsafe practices. The color associated with Caution is YELLOW.

IMPORTANT: Highlights information that must be heeded.

NOTE: A reminder of other related information that needs to be considered.

If Safety Decals on this machine are ISO two panel pictorial, decals are defined as follows:

- The first panel indicates the nature of the hazard.
- The second panel indicates the appropriate avoidance of the hazard.
- Background color is YELLOW.
- Prohibition symbols such as  and  if used, are RED.

Be certain all machine operators are aware of the dangers indicated by safety decals applied to the machine, and be certain they follow all safety decal instructions. Contact Loftness for safety decal replacement.

Loftness cannot anticipate every possible circumstance that may involve a potential hazard. The warnings in this owner's manual are not all inclusive.

Owner's Responsibility

Due to the potential danger of flying debris, it is the owner's responsibility and is **ABSOLUTELY MANDATORY** that **IMPACT-RESISTANT SHIELDING** be installed on the machine to protect the operator.

It is **ABSOLUTELY MANDATORY** that all personnel read and follow all safety precautions before operating the machine and attachment.

Make sure that all personnel have read this owner's manual, and thoroughly understand safe and correct installation, operation, and maintenance procedures.

Operate and maintain this machine in a safe manner and in accordance with all applicable local, state, and federal codes, regulations and/or laws; and in compliance with on-product labeling and this owner's manual instructions.

Make sure that all personnel know how to stop the machine and attachment by disengaging all controls. See "Mandatory Shut-Down Procedure" on page 6.

Make sure the attachment is installed on the machine correctly before being placed in service. At regular intervals thereafter, the attachment should be serviced in accordance with procedures outlined in this owner's manual.

Safety Instructions

Mandatory Shut-Down Procedure

- Stop the machine and attachment on a level surface and lower the attachment to the ground.
- Move throttle to idle position.
- Disengage all power to the attachment.
- Shut off engine and remove the key.

Wait until the rotor has stopped completely before inspecting the attachment.

Safety Rules

These are general safety considerations. Additional precautions may be necessary to operate your machine in a safe manner. Be certain you are operating your machine in accordance with all safety codes, OSHA rules and regulations, insurance requirements and local, state, and federal laws.

- Read and observe all warnings decals on the machine before attempting to operate the attachment. Do not attempt to operate this attachment unless all factory devices and decals are in place. Keep safety decals clean of dirt and grime. Keep all guards, shields and decals in place.
- Remove from area of operation all foreign objects such as bottles, rocks, wire, etc., that might become tangled in the rotor, causing damage to the machine or be thrown striking other objects.
- Do not allow any people and animals within 300 feet of the machine and attachment during operation.
- Do not allow anyone to operate the attachment until he or she has read the owner's manual and is completely familiar with all safety precautions. Keep the work area clear of all unauthorized personnel.
- Do not allow persons under the influence of alcohol, medications, or other drugs that can impair judgment or cause drowsiness to operate or maintain the machine.
- Always use an approved roll bar and seat belt for safe operation. Overturning a machine without a roll bar and seat belt can result in injury or death.
- Use the handholds and step plates when getting on and off the machine to prevent falls. Keep steps and platform cleared of mud and debris.
- Always have an operator in the machine while the attachment is in operation. Never leave the machine and attachment running and unattended.
- Operate the attachment only from the operator's seat.
- Keep your feet on the pedals, (floor plates) seat belt fastened snugly and seat bar lowered, (if equipped), when operating the attachment.
- The adjustable push bar could contact the machine in some positions. Before starting the power unit, set the push bar in the most forward position, then slowly rotate the attachment back while an assistant checks for clearance. Repeat this process in the other settings to determine which positions are usable with your machine.
- Never attempt to make any adjustments while the attachment is running or the key is in the "ON" position in the machine. Before leaving the operator's position, disengage power to the attachment, shut off engine and remove ignition key.
- Disengage auxiliary hydraulics and place all machine controls in neutral and engage the parking brake before starting the engine.
- Become familiar with and know how to operate all safety devices and controls on the machine and attachment before attempting to operate. Know how to stop the machine and attachment before starting it.
- Repeated impact of the knives with hard objects can cause excessive wear and damage to the skid-loader or attachment. Be sure to maintain recommended ground clearance as specified in this manual.
- Should excessive vibration occur, disengage the auxiliary hydraulics immediately and shut off engine. Do not continue to operate the attachment until the problem has been determined and corrected.
- Do not start, operate, or work on this attachment until you have carefully read and thoroughly understand the contents of this manual and the operator's manual for your machine.

Safety Instructions

Safety Rules (Cont'd)

- Keep children, bystanders and other workers off and away from the machine and attachment during operation. No riders allowed.
- Before inspecting, cleaning, lubricating, adjusting or servicing any part of the attachment, always exercise the Mandatory Shut-Down Procedure. See "Mandatory Shut-Down Procedure" on page 6. After service has been performed, be sure to restore all guards, shields and covers to their original position.
- Make sure the operator's area is clear of any distracting objects. Keep work areas clean and free of grease and oil to avoid slipping or falling.
- Make sure all controls, (levers, pedals and switches), are in NEUTRAL position before starting the engine.
- Before leaving the operator's position for ANY reason or allowing anyone to approach the machine and attachment, always perform the mandatory shutdown procedure.
- Do not wear loose hanging clothes, neckties or jewelry around rotating parts. Long hair is to be placed under a cap or hat. These precautions will help prevent you from becoming caught in any moving parts on the machine and attachment.
- Before working under the attachment, be certain it is securely blocked!
- Do wear safety glasses, ear protection, respirators, gloves, hard hats, safety shoes and other protective clothing when required.
- Periodically check all guards, shields and structural members. Replace or repair anything that could cause a potential hazard.
- Do not replace components or parts with other than factory-recommended service parts. To do so may decrease the effectiveness of the machine.
- It is the operator's responsibility to be aware of machine and attachment operation and work area hazards at all times.
- Never operate the attachment without adequate light and visibility.
- Keep hands and feet clear! Never step over or climb over the attachment while the rotor is engaged or the engine is running; entanglement could occur.
- Operators are responsible to know the location and function of all guards and shields including but not limited to belt drives and rotor. Operators are responsible to make certain that all guards are in place when operating the machine and attachment.
- Operators are responsible to be aware of safety hazard areas and follow instructions on warning, caution, or danger decals applied to the machine.
- Know the area before operating the machine. Be aware of power lines or other equipment.
- Do not lubricate parts while the machine is running.
- Do not smoke while servicing the machine.

Hydraulic Safety

- The hydraulic system is under high pressure. Make sure all lines and fittings are tight and in good condition. These fluids escaping under high pressure can have sufficient force to penetrate skin and cause serious injury.
- Never check for leaks by using any part of your body to feel for escaping fluid.



WARNING: *Contact with high pressure fluids may cause fluid penetration and burn hazards. Fluid that is under pressure can penetrate body tissue. Fluid penetration can cause serious injury and possible death. If fluid is injected into the skin, seek medical attention immediately!*

California Proposition 65 Warning



WARNING: *This product can expose you to Mineral Oil, which is known to the State of California to cause cancer. For more information, go to www.p65warnings.ca.gov.*

A decal with this warning statement is adhered to the machine. If the decal should become worn or missing, replace immediately

Safety Instructions

Battle Ax Skid Loader Identification

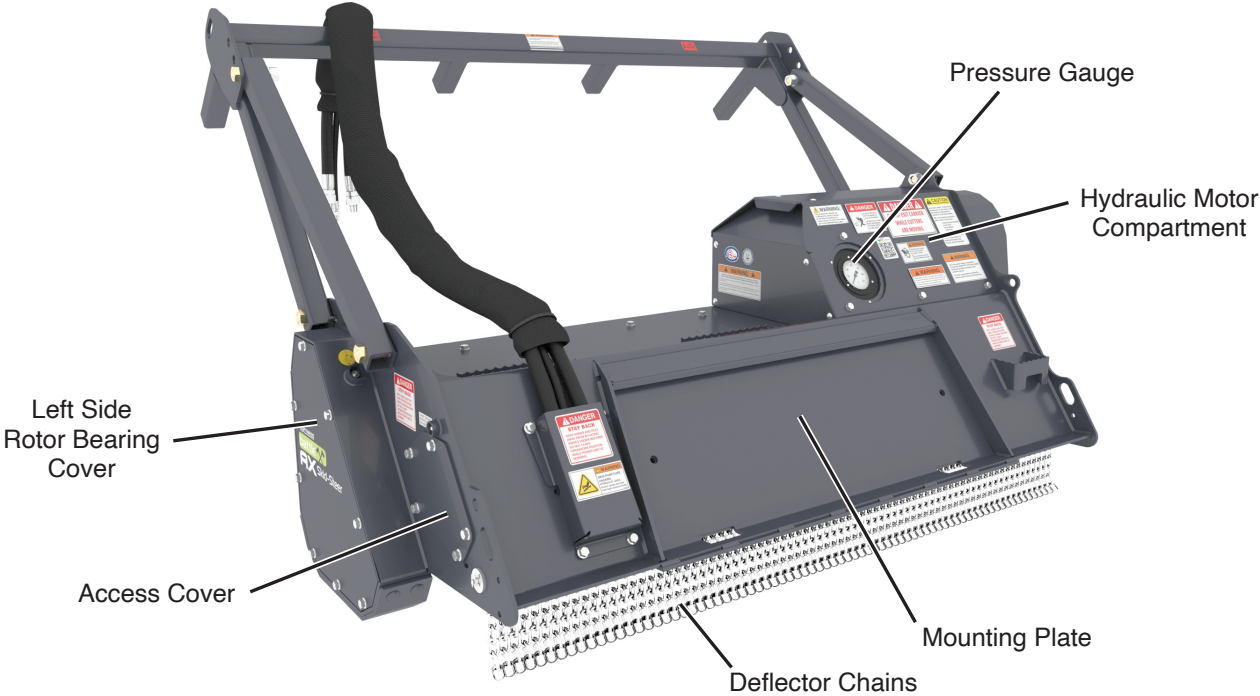

Safety Decal Locations

Check and replace any worn, torn, hard to read or missing safety decals on your machine.

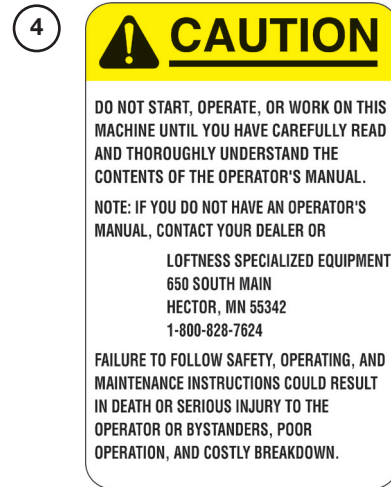

Part No. 4256



Part No. 203264

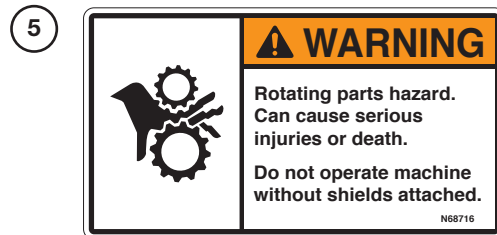

Part No. N68716



Part No. N68724

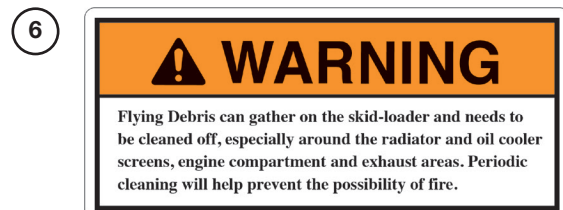

Part No. N20661



Part No. 200491

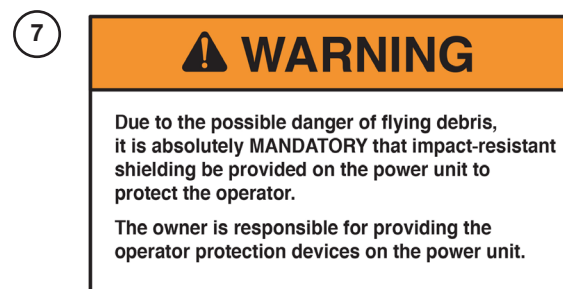

Part No. N17013

Safety Instructions

Safety Decal Locations (Cont'd)

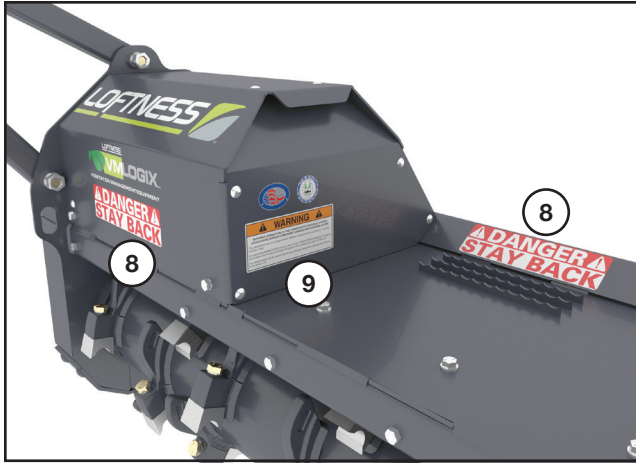

Part No. 4334

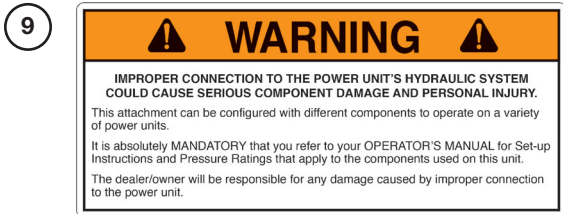

Part No. N28385

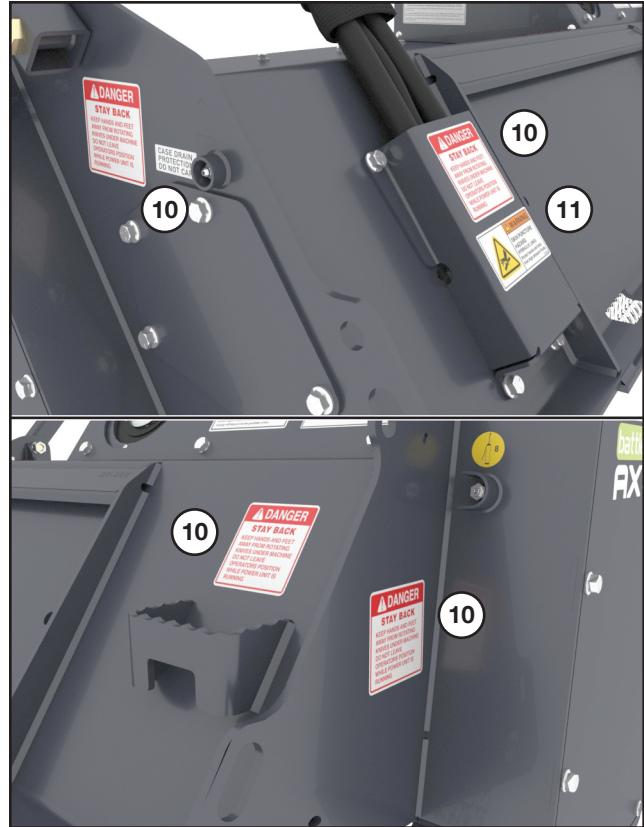

Part No. N28386



Part No. N23506

Safety Decal Locations (Cont'd)



12

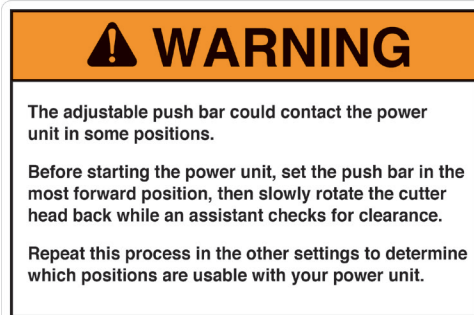

Part No. N17014

13



Part No. N29769

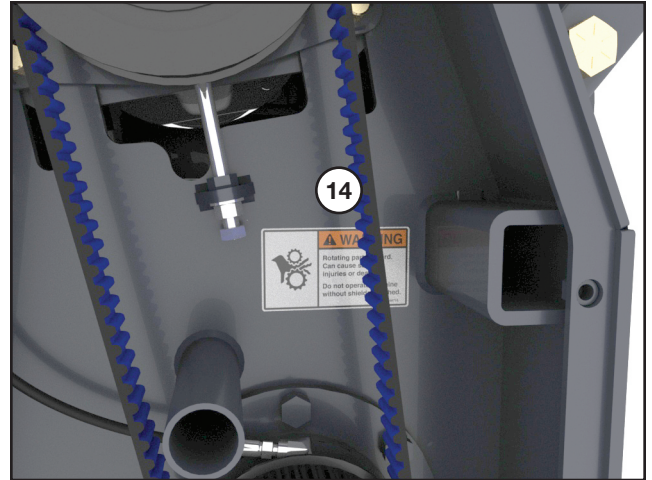

14



Part No. N68716



Set-up Instructions

Pusher Bar Assembly

The Battle Ax is shipped with the pusher bar in an upright position. Follow the procedure below to get the machine into the operating position.



The pusher bar can be set into one of three different operating positions as shown above. Determine which of the three positions is desired before assembling.



NOTE: Assembling the pusher bar requires two people and the use of an approved lifting device (1) to support the push bar as it is being adjusted.

Ensure the pusher bar is being safely supported.

Loosen nuts at locations (2 and 3).

Remove the nut, bolt, and washer at location 4 that secures the arm (5) to the frame during shipping. Repeat the procedure on the other side.

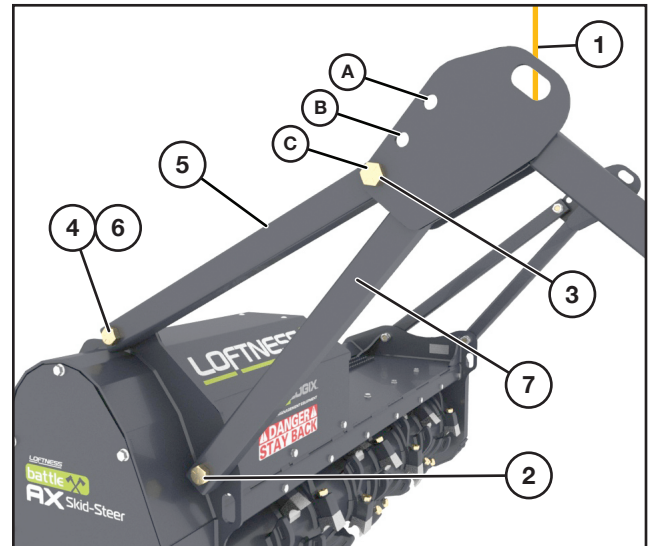

Move arm (5) into position so the hole in the lower end of the arm aligns with the operation hole (6) of the side plates on the frame (indicated by the shipping tag). Remove the shipping tag.

NOTE: The pusher bar is factory-set so the upper hole in each arm aligns with hole "C". Repositioning the upper hole in the arms to another hole (A or B) in the sides of the pusher will provide a different angle for the pusher bar during operation. If a different hole position is desired follow the procedure below.

Adjusting the pusher bar requires two people and the use of an approved lifting device (1) to support the pusher bar as it is being adjusted.

Remove the nut, bolt, and washer at location 3 from the bottom hole of the pusher side and upper hole of the arm. Once the hardware is removed, let the arm (5) rest on the pusher bar side assembly (7). Then loosen the nut at locations 2 and 4. Repeat the procedure on the other side.

Using the hoist, adjust the angle of the pusher bar while simultaneously positioning one of the arms until the upper hole in the arm aligns with the desired hole in the side of the pusher.

NOTE: A punch may be needed to assist with alignment.

(Procedure continued on following page.)

Set-up Instructions

Pusher Bar Assembly (Cont'd)

Reinstall the hardware in the correct order and hand-tighten.

Move the opposite arm into place so the upper hole aligns with the corresponding hole position as the opposite side. Reinstall the hardware in the correct order.

Tighten all hardware on both sides.

The strap/chain from the hoist can now be removed.

Removing Shipping Stands

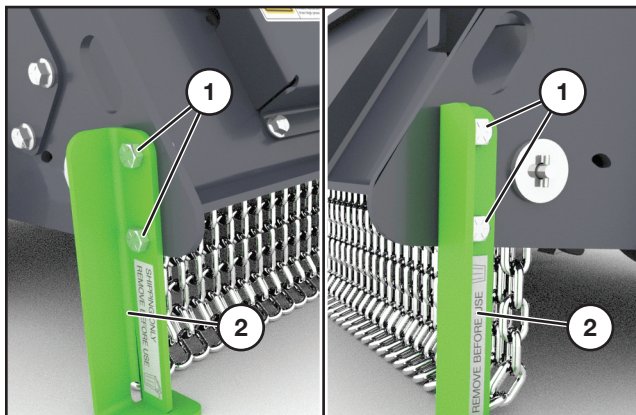

Unfasten the bolt, washer, and nut sets (1) (two sets on each side) and remove the shipping stands (2).

NOTE: Do not discard the shipping stands. They are used to stabilize the Battle Ax during storage. Keep in a secure location until ready to store.

Installing the Battle Ax to the Loader

Fully raise the attachment-locking levers on the loader mounting plate.



Tilt the loader mounting plate ahead. Drive forward with the loader and hook the top edge of the loader mounting plate under the top flange (1) on the Battle Ax mounting plate. Be careful not to damage the locking levers on the loader mounting plate.

Tilt the loader mounting plate back until the Battle Ax mounting plate is firmly against the loader mounting plate, but Do Not lift the attachment off the ground.



WARNING: Before you leave the operator's seat: Lower the lift arms, put the attachment on the ground. Stop engine and remove ignition key. Engage the parking brake.

Fully lower the attachment-locking levers on the loader mounting plate.



WARNING: Locking-wedge pins must extend through the holes in attachment-mounting plate. Levers must be fully down in the locked over-center position. Failure to secure wedge pins can allow attachment to come off, causing serious injury or death.

Set-up Instructions

Installing the Battle Ax to the Loader (Cont'd)

Hydraulic Connections

 **WARNING:** Hydraulic Lines. Protect hands and body from high pressure fluids. Pressurized fluids can penetrate the skin. Disconnect and lock out power source before disconnecting and/or connecting hydraulic hoses.

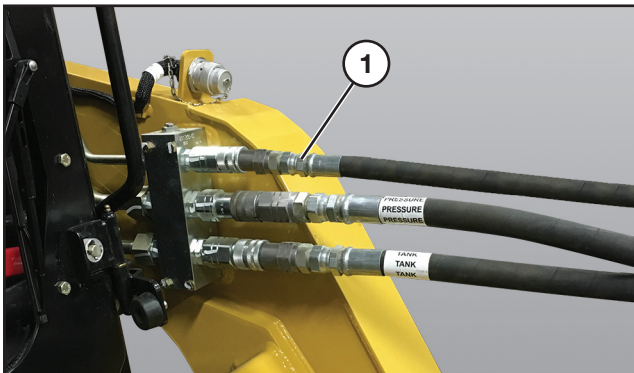

NOTE: The hydraulic hose quick couplers shown above are not supplied with the Battle Ax.

Install the Battle Ax quick couplers to the loader.

NOTE: The case drain quick coupler (1) of the Battle Ax must be connected to the loader's auxiliary hydraulic system for proper operation of the Battle Ax.

IMPORTANT: It is the owner's responsibility to assure that the hydraulic hoses from the power unit to the attachment are not caught in pinch points, or in any way damaged by moving parts.

Checking Rotor Rotation

 **DANGER:** Keep hands, feet, and clothing clear of rotor and bearings while the loader is running.

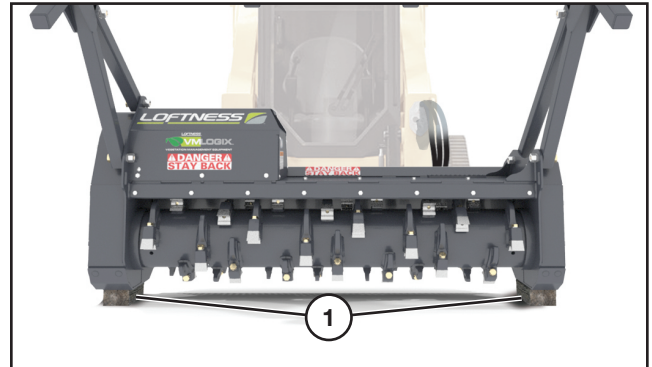

Raise the Battle Ax off the ground and place blocks (1) underneath the skids. Lower the Battle Ax down on the blocks.

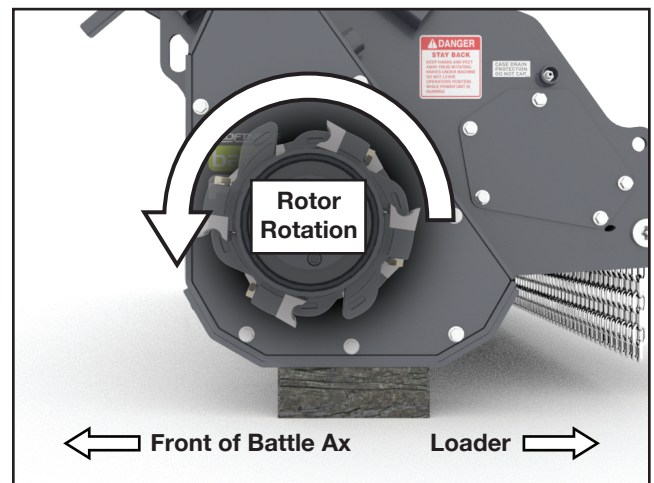

Engage the loader auxiliary hydraulics, the rotor should start rotating in a forward direction. The rotation should be counterclockwise as viewed from the left side of the Battle Ax.

NOTE: If the rotor is rotating backward, reverse the quick couplers (not supplied) on the Battle Ax hydraulic hoses. Re-install the couplers (not supplied) on the loader and test for correct rotor rotation.

 **WARNING:** The Battle Ax can be damaged if rotor is operated in reverse rotation.

NOTE: Keep the Battle Ax on the blocks for checking the rotor speed. See next procedure for instructions.

Set-up Instructions

Checking Rotor Speed

 **DANGER:** Shut down power from the loader before removing the belt cover and applying reflective tape to the sprocket. Keep the Battle Ax skids on blocks for this procedure.



Remove the belt cover. See “Removing Belt Cover” on page 21 for instructions.

Apply a small piece of reflective tape (1) to the outer edge of the lower sprocket.

Start the loader and engage the auxiliary hydraulics.

 **DANGER:** Keep hands, feet, and clothing clear of the rotor, belt, and sprockets while the loader is running.

Point an electronic (photo) tachometer (2) towards the edge of the sprocket to check the rotor speed.

NOTE: The tachometer is not supplied with the Battle Ax.

Test the rotor RPM with the loader engine at full throttle.

Shut down the loader when done.

See “Motor & Sprocket Selection Chart” on page 29 for rotor RPM. If it is outside this recommended range, it may be necessary to disconnect the Battle Ax and test the hydraulic output of the loader with a flow meter to see if it corresponds with the factory specifications.

Turn power off from loader and return the belt cover to position, securing with the eight bolts.

Cutter Bar Adjustment/Removal

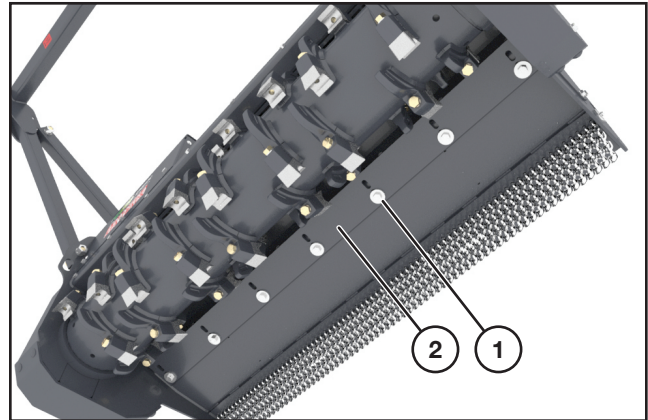

NOTE: The cutter bar can be adjusted back or forward to increase or decrease the distance between the bar and the rotor.

Most operators find the best performance is achieved by adjusting the cutter bar as close as the slots will allow (approximately a 1/4" gap from knife to cutter bar). A wider gap generally increases finished particle size and horsepower requirements.

 **WARNING:** Shut down and disconnect hydraulic hoses from skid loader before adjusting the cutter bar.

Loosen the seven bolts with washers (1) securing the cutter bar (2) to the frame. Move the cutter bar either forward or back making sure the distance moved is consistent through the entire length of the cutter bar. Retighten bolts. Torque to 165 ft.-lbs.

Over time, the cutter bar edge will become worn and rounded from use. There are a total of 4 wear edges available by removing and flipping the bar, side to side and front to back.

 **CAUTION:** If adjusting the cutter bar after the machine has been used, the cutter bar should be completely removed to clear any debris away from contact surfaces before assembly and tightening. FAILURE TO DO SO COULD RESULT IN SEVERE DAMAGE TO THE MACHINE!

Operating Instructions

Getting Started

For best results, the areas to be mowed should be free of debris such as bottles, metal objects, rocks and wire etc. The teeth cut and pulverize the brush, grass and weeds.

Operate the Battle Ax as low to the ground as possible without the teeth striking ground or other obstructions. Because of the high speed of the teeth, the life of the teeth will be reduced if it is operated in rocky terrain or in areas where many obstacles are present. The Battle Ax deposits cut material over the entire width-of-cut, which eliminates bunching or windrowing behind the machine.



WARNING: Due to the potential danger of flying debris, it is the owner's responsibility and is "ABSOLUTELY MANDATORY that IMPACT-RESISTANT SHIELDING" be installed on the machine to protect the operator.



WARNING: Lifting or tilting the Battle Ax increases the risk of flying debris.



DANGER: Keep hands and feet out! Do not step on or climb over the unit while machine is in operation, or engine is running. Do not carry passengers.



WARNING: Do not operate the attachment above the rated RPM. Check with your Loftness dealer to be sure your attachment is set-up with the correct hydraulic motor to match the hydraulic flow GPM (Gallons Per Minute) of your machine.



WARNING: Flying debris can gather on the loader and needs to be cleaned off, especially around the radiator, oil cooler screens, engine compartment, and exhaust areas. Periodic cleaning will help prevent the possibility of fire.



DANGER: DO NOT allow ANY people or animals within 300 feet of the work area while operating this machine.

Operation



WARNING: Always stop engine and remove key before leaving operators seat.



Tilt attachment mounting frame back and raise the Battle Ax slightly above the ground when moving the machine.

NOTE: Operate the Battle Ax as low to the ground as possible without the teeth striking ground or other obstructions.



WARNING: Lifting or tilting the Battle Ax increases the risk of flying debris.

Lower mulching head so skids are on ground.

Set engine speed to low idle and engage the mulching head.

Slowly increase engine speed to high idle.

Move the loader and Battle Ax forward and begin mowing.

NOTE: Various mowing conditions, and desired finished cut appearance, will determine proper ground speed.

Operating Tips

To reduce rotor jams, approach brush and trees at a slow speed.

When operating the mulching head near the ground, keep as low to the ground as possible without the teeth striking ground or other obstructions.

NOTE: Because of the high speed of the rotor, the life of the teeth will be reduced if it is operated in rocky terrain or in areas where many obstacles are present.

Operating Instructions

Clearing Jams

If the rotor stalls, or gets jammed with debris, stop rotor and raise slightly. Start rotor again to free debris

	<p>WARNING: Do not attempt to dislodge jams by hand while the loader is running. Shut down and lock out power from the loader before attempting to remove debris by hand.</p>
---	--

Log Moving



Disengage hydraulic power to rotor before moving logs and brush with pusher bars.

Raise the loader lift arms and tilt the Battle Ax forward until the push bar extensions are over the log or item being moved. Lower the lift arms and position the log between push bar extensions and the Battle Ax. Move the loader backwards, dragging the log to the desired location.

Hydraulic Hose Storage



When not in use, drape the hydraulic hoses over the pusher bar and protect the hose couplers. Do not allow the couplers to come in contact with the ground, foliage, or any other machinery.

General Maintenance

To ensure efficient operation, you should inspect, lubricate, and make necessary adjustments and repairs at regular intervals. Parts that are starting to show wear should be ordered ahead of time, before a costly breakdown occurs and you have to wait for replacement parts. Keep good maintenance records, and adequately clean your Battle Ax after each use.

Proper lubrication is important. Too little lubricant will cause premature failure of a bearing. Too much lubrication usually causes high operating temperature and early failure of seals. Follow all lubrication instructions and schedules included in this section.

Maintenance Schedule

HOURS	SERVICE POINTS	SERVICE REQUIRED					
		CHECK	CLEAN	CHANGE	GREASE	ADJUST	OIL
Every 8	Machine		X				
	Loose Bolts					X	
	Hoses and Wiring	X					
	Oil Leaks	X					
	Rotor Bearing				X		
	Teeth	X					
Every 100	Belt Tension	X					
	Drive Belt	X					
	Safety Labels	X					
Every 500	Overhung Load Adapter	X					X

Lubrication

Grease Points Location

Use a #2 general purpose lithium based grease unless noted otherwise.

NOTE: Replace any broken or missing grease fittings. Be sure to clean fittings before greasing.



DANGER: Shut down and lock out power from the loader before lubricating the Battle Ax. Failure to do so could result in serious injury or death.

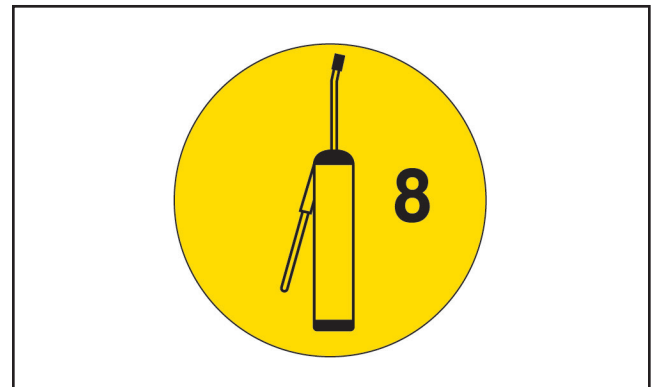

NOTE: Lubricate the grease point every "X" hours indicated on the decal adjacent to the grease point.

See "Battle Ax Skid Loader Identification" on page 8 for component location and identification.

(Procedure continued on following page.)

Maintenance

Lubrication (Cont'd)

Grease Points Location (Cont'd)



Location: Left side rotor bearing (1).
Interval: Every 8 hours of operation.

NOTE: Rotor bearings cannot be damaged by over-greasing. Lubricate the fittings until a small amount of grease is purged from the bearing.



Location: Right side rotor bearing (2).
Interval: Every 8 hours of operation.

NOTE: Rotor bearings cannot be damaged by over-greasing. Lubricate the fittings until a small amount of grease is purged from the bearing.

Overhung Load Adapter

The motor cover must be removed to access the overhung load adapter. Refer to “Removing Motor Cover” on page 22 for instructions.

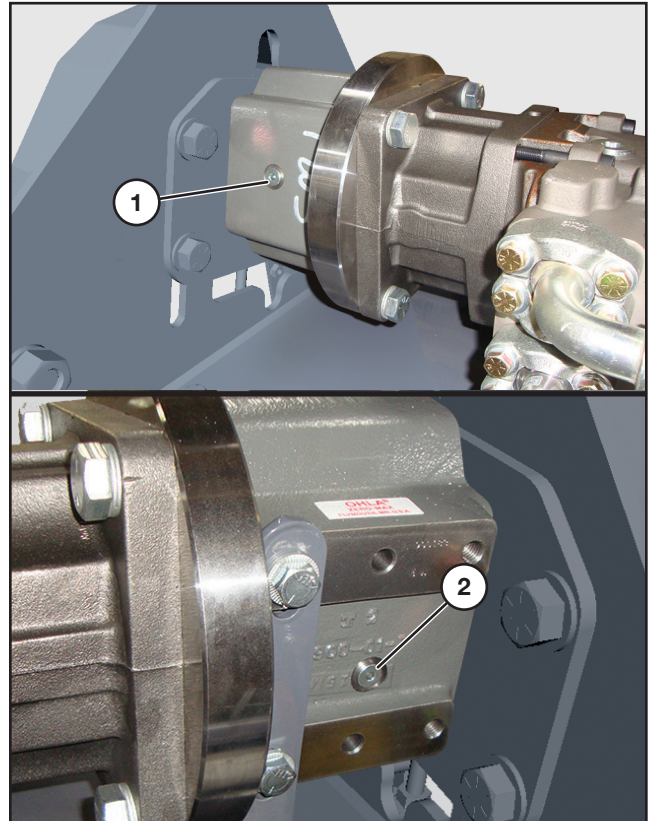

Remove the plug from the upper port (1) located on front side of the overhung load adapter, and the plug from the lower port (2) located on the back side.

Using a funnel, add hydraulic oil into the upper port (1) until it runs out through the bottom port (2).

- Approximately 6 oz. for OHLA (N51193) - variable motor system.
- Approximately 4 oz. for OHLA (N16416) - fixed motor system.

Reinsert the plug back into the lower port and tighten.

Return the remaining plug back into the upper port and tighten.

NOTE: If replacing bearings or seals in the overhung load adapter, be certain to refill with hydraulic fluid after reassembly.

Removing Belt Cover



DANGER: Shut down power from the loader before removing the belt cover. Failure to do so could result in serious injury or death.

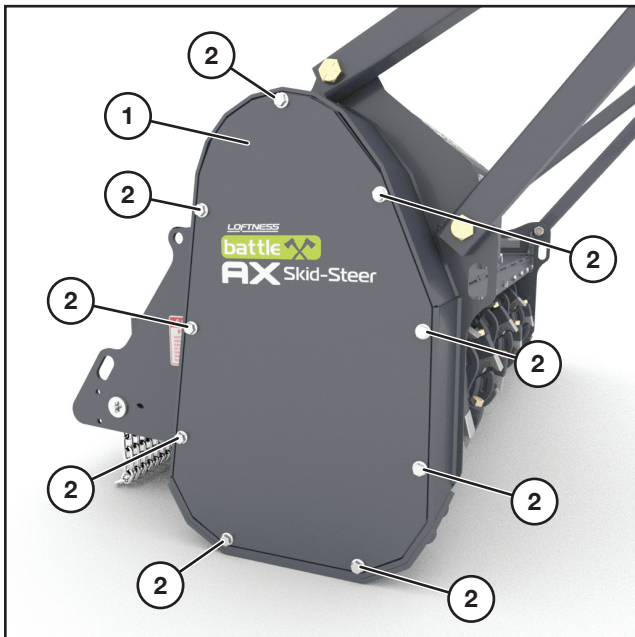

CAUTION: The cover is heavy. Support the cover when removing.

To remove the cover (1), unscrew the nine bolts (2) and lift the cover off of the frame.

When maintenance/repairs are complete, return the cover(s) back into position and tighten and secure all bolts.

Removing Rotor Bearing Cover and Valve Access Cover



DANGER: Shut down power from the loader before removing the covers. Failure to do so could result in serious injury or death.

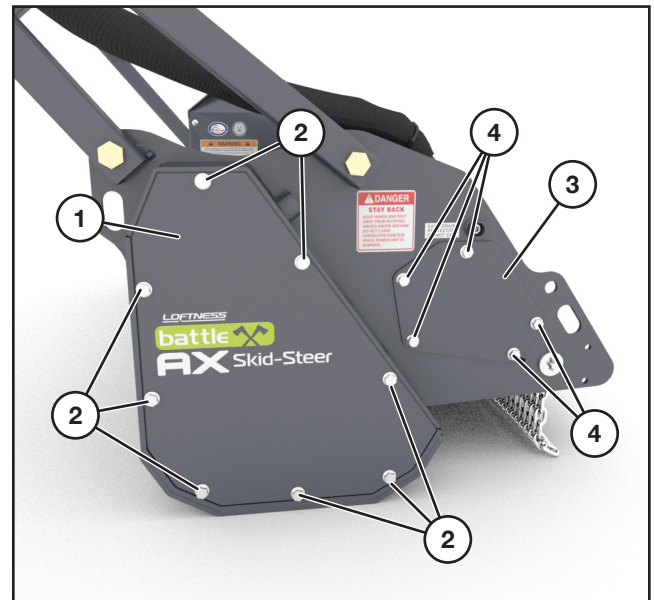

To remove the rotor bearing cover (1), unscrew the eight bolts (2) and lift the cover off of the frame.

To remove the left side valve access cover (3), unscrew the five bolts (4) and lift the cover off of the frame

When maintenance/repairs are complete, return the cover(s) back into position and tighten and secure all bolts.

Maintenance

Removing Motor Cover

 **DANGER:** Shut down power from the loader before removing the motor cover. Failure to do so could result in serious injury or death.



Remove the 3 bolts (1) on the front of the motor cover (2) followed by the four bolts (3) at the rear. Use the handle (4) to lift the cover off of the machine.

When maintenance/repairs are complete, return the cover(s) back into position and tighten and secure all bolts.

Skid Removal/Replacement

 **DANGER:** Shut down power from the loader before removing the skids. Failure to do so could result in serious injury or death.

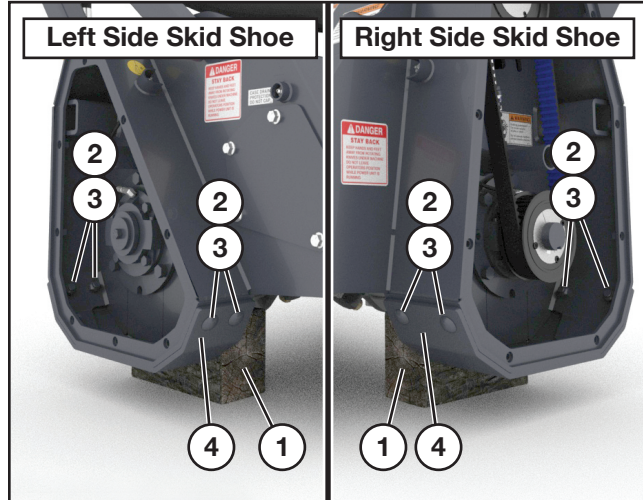

Lift the Battle Ax off of the ground about 6 inches. Place blocks (1) under the rotor (not under teeth) to support the Battle Ax when lowered. DO NOT place blocks under the skids.

For right side skid shoe, first remove the belt cover. Refer to “Removing Belt Cover” on page 21 for instructions.

For left side skid shoe, first remove the bearing cover. Refer to “Removing Rotor Bearing Cover and Valve Access Cover” on page 21 for instructions.

Remove the nuts (2) and slide the carriage bolts (3) out. Lower the skid (4) and remove.

To install a new skid shoe, align the holes in the skid shoe with the holes on frame. Re-install the bolts, add the nuts and tighten securely.

Belt Tension Adjustment



DANGER: Shut down and lock out power from the loader before adjusting the drive belt. Failure to do so could result in serious injury or death.

Remove belt cover and motor cover. Refer to “Removing Belt Cover” on page 21 and “Removing Motor Cover” on page 22 for instructions.

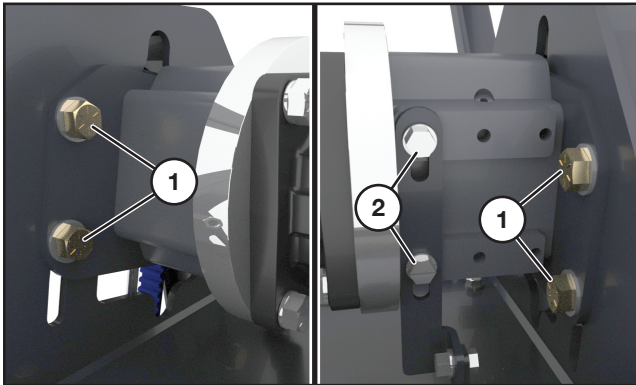

Loosen the four mounting bolts (1). Then loosen the overhung load adapter support bracket bolts (2).

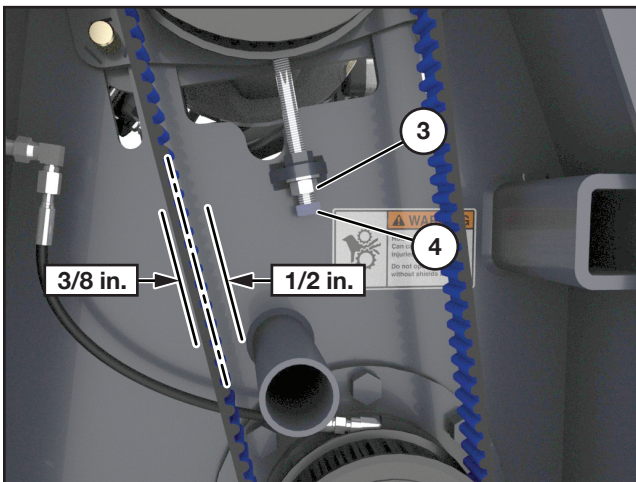

Loosen the jam nut (3). Then turn the hex bolt (4) to either increase or decrease belt tension.

Belt should move no more than 3/8 in. (9.5 mm) to the left, and no more than 1/2 in. (12.7 mm) to the right when pressure applied at the midpoint.

Retighten the jam nut (3).

Retighten overhung load adapter support bolts (1) and the mounting bolts (2).

Replacing Belt

To replace the belt, follow the procedures for “Belt Tension Adjustment” preceding this subsection and decrease the belt tension additionally to allow the belt to slide over the top sprocket.

NOTE: When replacing or installing a new belt, align the grooves in the belt with the upper and lower pulleys.

Install the belt and adjust the tension accordingly. Refer again to the “Belt Tension Adjustment” procedure and follow the instructions completely.

Sprocket Removal

The steps to remove either the upper or lower sprocket are identical. For this procedure the upper sprocket is discussed. Follow the same procedure to remove the lower sprocket.

NOTE: See page 40 for a master drawing of all belt/sprocket combinations. The page provides a reference to an exploded view with a complete parts list for each combination.

1. Disconnect or turn off all power to the Battle Ax.



DANGER: Shut down and lock out power from the loader before removing sprockets. Failure to do so could result in serious injury or death.

Remove the drive belt by following the instructions in “Belt Tension Adjustment” and “Replacing Belt” preceding this subsection.

(Procedure continued on following page.)

Maintenance

Sprocket Removal (Cont'd)

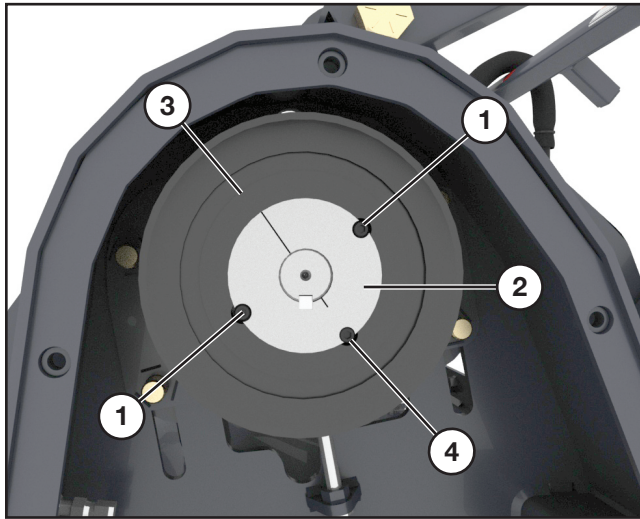

2. Remove the two screws (1) from the taper lock bushing (2) of the sprocket (3).
3. Insert one of the screws into the threaded hole (4).
4. Tighten the screw until bushing grip is released. (If excessively tight, lightly hammer face of sprocket using drift pin or sleeve).

NOTE: *Never hit sprocket directly with hammer.*

5. Replace the sprocket by cleaning the shaft, bore of bushing, outside of bushing and hub bore of all oil, paint and dirt. File away any burrs.
6. Insert bushing into hub. Match the hole pattern, not threaded holes (each complete hole will be threaded on one side only).
7. Apply a thread-locking compound to screws and thread into the two opposing holes.
8. Position assembly on shaft and alternately torque screws to 35 ft.-lbs.
9. To increase gripping force, hammer face of bushing using drift or sleeve.

NOTE: *Do not hit bushing directly with hammer.*

10. Re-torque screws after hammering.
11. Recheck screw torque after initial run-in, and periodically thereafter, repeat steps 4, 5 & 6 if loose.
12. Check alignment of the sprocket. Repeat sprocket removal and assembly procedures if necessary.

Tooth Removal and Installation

Quadco Teeth

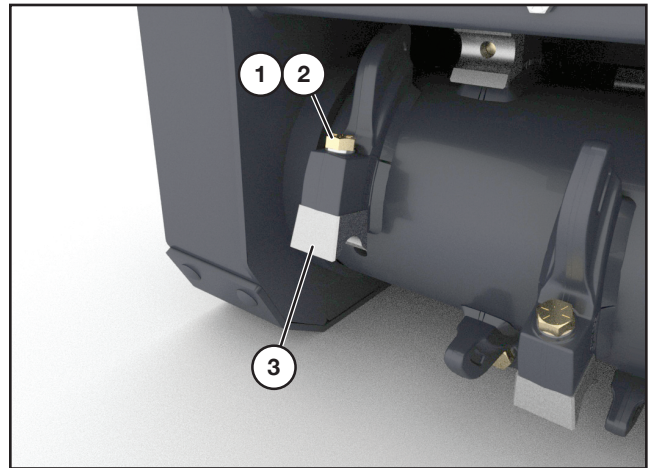

Remove the bolt and washer (1 and 2) and tooth (3).

Use copper based anti-seize when reinstalling the bolts. Torque to 240 ft.-lbs.

IMPORTANT: *When a damaged tooth is replaced, the tooth directly opposite (180 degrees) must be replaced at the same time to retain balance.*

Tooth Sharpening (Quadco)

NOTE: The teeth need to be kept sharp to maintain the most effective operation of the attachment. Daily inspection and touch up is recommended.

NOTE: The teeth can either be removed from the attachment or remain installed for sharpening.



WARNING: Rotor must be stabilized to prevent accidental rotation any time the rotor is exposed for service work.

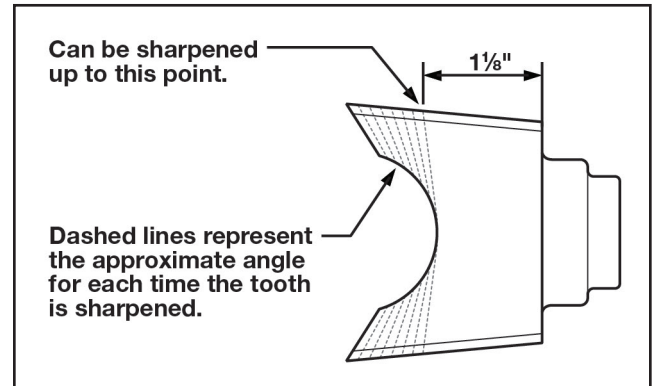
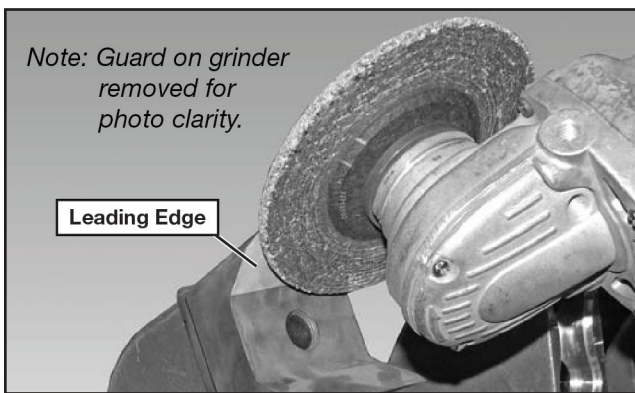

NOTE: It is not necessary to match the factory angle on the underside of the cutting edge when re-sharpening. Sharpen each tooth at a slight angle for each successive sharpening (represented by the dashed lines shown in the illustration above). When the cutting edge of the tooth is 1-1/8 in. from the back side of the tooth, the tooth must be replaced.

NOTE: The Quadco cutter teeth have been heat treated to a specific hardness. Care must be taken to avoid overheating the leading edge of the tooth while sharpening. If the coloring in the tooth changes to either a blue or brown during the sharpening, you have removed the temper and the tooth will not hold its cutting edge.

NOTE: When re-sharpening teeth using machine shop equipment, avoid overheating the teeth by using a flood coolant system.

NOTE: When re-sharpening teeth using a hand grinder, avoid overheating the tooth by lightly grinding each tooth, moving across the entire row of teeth before returning to the first tooth to repeat the procedure.

NOTE: Sharpen each tooth equally to maintain rotor balance. Always return tooth to its original location if it is removed from the rotor for sharpening.

Maintenance

Recutter Removal/Replacement

 **DANGER:** Shut down power from the loader before removing and replacing the recutter. Failure to do so could result in serious injury or death.

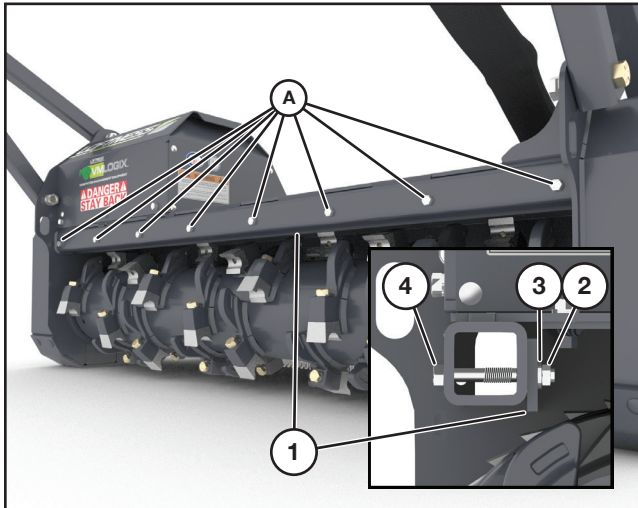

NOTE: Mounting hardware for the recutter is shown at the locations above (A). There are seven hardware locations for the 61" Battle Ax, and eight locations for the 71" Battle Ax.

To remove the recutter (1), unfasten all hardware shown at locations "A" - the 1/2" nuts (2), 1/2" washers (3), and the 4" bolts (4). Support the recutter before removing the last two bolts.

Over time, the recutter edge will become worn and rounded from use. There are a total of 4 wear edges available by removing and flipping the bar, side to side and front to back.

 **CAUTION:** If adjusting the recutter after the machine has been used, the recutter should be completely removed to clear any debris away from contact surfaces before assembly and tightening. FAILURE TO DO SO COULD RESULT IN SEVERE DAMAGE TO THE MACHINE!

To install the clean or new recutter, align the holes in the recutter with the holes on the frame. Re-install the bolts, then add the washers and nuts. Torque to 83 ft.-lbs.

Installing/Removing the Hood Liner

 **DANGER:** Shut down power from the loader before installing or removing the hood liner. Failure to do so could result in serious injury or death.

Clearing the Cutter Bar

For a new or unused machine:

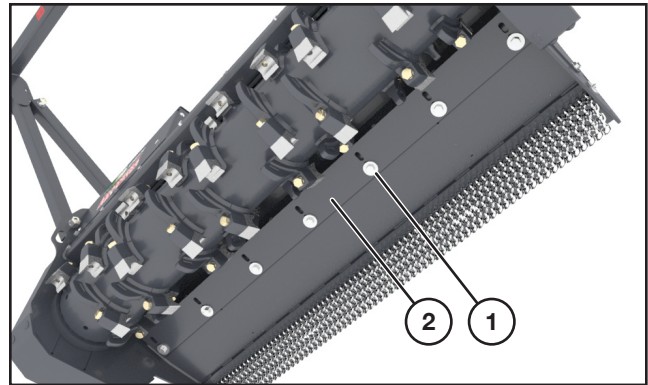

Loosen (do not remove) the hardware (1) securing the cutter bar (2) (seven securing locations).

This will provide enough room to mount the hood liner without removing the cutter bar.

For a machine that has already been used or put into service:

IMPORTANT: Over time, a Battle Ax put into service will collect dirt, debris, and other matter on and around the cutter bar and the recutter. For this reason it is important that both are completely removed and all contact surfaces cleaned before it can be returned to the machine.

To remove the cutter bar, see "Cutter Bar Adjustment/Removal" on page 16 for complete and thorough instructions. To remove the recutter, see "Recutter Removal/Replacement" on this page. Obey all cautions and warnings described in each procedure.

 **CAUTION:** The cutter bar must be completely removed to clear any debris away from contact surfaces before assembly and tightening. FAILURE TO DO SO COULD RESULT IN SEVERE DAMAGE TO THE MACHINE!

(Procedure continued on following page.)

Installing/Removing the Hood Liner (Cont'd)

Mounting the Hood Liner

Remove the motor cover to access some hardware locations that are used to secure the hood liner. Refer to "Removing Motor Cover" on page 22 for instructions.

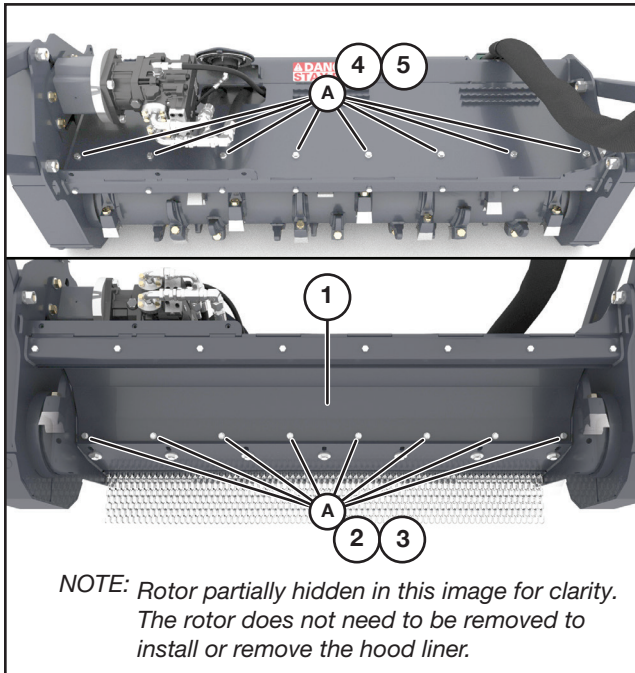

NOTE: Before installing the hood liner, remove the factory-installed hardware shown at the locations above (A). This hardware is no longer used.

There are fourteen hardware locations for the 61" Battle Ax, and sixteen locations for the 71" Battle Ax.

Clean the rotor chamber as well as all hardware locations shown above.

Place the hood liner (1) into position, then align the holes in the hood liner with the threaded holes in the frame made available after removing the factory-installed hardware.

Install the supplied 1-3/4" bolts (2) with 1/2" washers (3) through the back of the liner and into the threaded holes on the frame. Then install the 1-1/4" bolts (4) with 1/2" washers (5) through the top of the frame and into the weld nuts on the hood liner. Tighten securely.

Retightening/Reinstalling the Cutter Bar and Recutter

If the hood liner was installed onto a new or unused Battle Ax, retighten all hardware securing the cutter bar.

If the hood liner was installed onto a Battle Ax that has been used or already put into service, make sure all contact surfaces on the cutter bar, the recutter, and on the Battle Ax have been thoroughly cleaned and are clear of debris.

Remount the cutter bar. See "Cutter Bar Adjustment/Removal" on page 16 for installation instructions.

Remount the recutter. See "Recutter Removal/Replacement" on page 26 for installation instructions.

Maintenance

Storage

End of Season

- Clean entire Battle Ax thoroughly.
- Clean belt and sprockets, relax the belt tension.
- Lubricate all parts of the machine. See “Lubrication” on page 19.
- Make a list of all worn or damaged parts and replace them.
- Paint all parts that are worn or rusted.
- Store Battle Ax in a clean, dry area.
- Review the Battle Ax operator’s manual.
- Secure hydraulic hoses in storage position. See “Hydraulic Hose Storage” on page 18.

Beginning of the Season

- Review the Battle Ax operator’s manual.
- Lubricate all parts of the machine. See “Lubrication” on page 19.
- Tighten all bolts, nuts, and set screws. See “Torque Specifications” on page 87.
- Adjust belt tension. See “Belt Tension Adjustment” on page 23.
- Replace all damaged, worn or missing decals.
- Install the Battle Ax on a loader and test for proper operation.



WARNING: *DO NOT* allow *ANY* people or animals within 300 feet of the work area while operating this machine.

Motor & Sprocket Selection Chart

Variable Displacement Motor (Parker)

Standard Speed

GPM	VARIABLE DISPLACEMENT MOTOR NUMBER PARKER	DISPLACEMENT LOFTNESS MOTOR NUMBER	ROTOR RPM	TOP SPROCKET (LOFTNESS NUMBER) BOTTOM SPROCKET (LOFTNESS NUMBER) BELT LENGTH (LOFTNESS NUMBER)
28	44, 45	90cc - 110cc (5.4921ci - 6.71ci) 207679	1683	50 Top Sprocket N38471 35 Bottom Sprocket 203001 1568 37 Synchronous Belt N34646 Model Code "T"
29			1743	
30			1803	
31			1863	
32			1923	
33	44, 45	90cc - 110cc (5.4921ci - 6.71ci) 207679	1753	48 Top Sprocket N38492 38 Bottom Sprocket N38490 1568 37 Synchronous Belt N34646 Model Code "A"
34			1806	
35			1859	
36			1912	
37			1965	
38	44, 45	90cc - 110cc (5.4921ci - 6.71ci) 207679	1798	45 Top Sprocket N47578 40 Bottom Sprocket N38491 1568 37 Synchronous Belt N34646 Model Code "B"
39			1845	
40			1892	
41			1940	
42			1988	
43	44, 45	90cc - 110cc (5.4921ci - 6.71ci) 207679	1893	45 Top Sprocket N47578 43 Bottom Sprocket N34647 1568 37 Synchronous Belt N34646 Model Code "D"
44			1937	
45			1981	
46			2025	
47			2069	
48	44, 45	90cc - 110cc (5.4921ci - 6.71ci) 207679	1929	43 Top Sprocket N34647 45 Bottom Sprocket N47578 1568 37 Synchronous Belt N34646 Model Code "H"
49			1969	
50			2010	
51			2050	
52			2090	
53	44, 45	90cc - 110cc (5.4921ci - 6.71ci) 207679	1981	40 Top Sprocket N38491 45 Bottom Sprocket N47578 1568 37 Synchronous Belt N34646 Model Code "I"
54			2019	
55			2056	
56			2093	
57			2131	
58	44, 45	90cc - 110cc (5.4921ci - 6.71ci) 207679	2033	40 Top Sprocket N38491 48 Bottom Sprocket N38492 1568 37 Synchronous Belt N34646 Model Code "J"
59			2068	
60			2103	
61			2138	
62			2173	

(Charts continued on following page.)

Maintenance

Motor & Sprocket Selection Chart (Cont'd)

Variable Displacement Motor (Parker) (Cont'd)

High Speed

GPM	VARIABLE DISPLACEMENT MOTOR NUMBER PARKER	DISPLACEMENT LOFTNESS MOTOR NUMBER	ROTOR RPM	TOP SPROCKET (LOFTNESS NUMBER) BOTTOM SPROCKET (LOFTNESS NUMBER) BELT LENGTH (LOFTNESS NUMBER)
32	44, 45	90cc - 110cc (5.4921ci - 6.71ci) 207679	1923	50 Top Sprocket N38471 35 Bottom Sprocket 203001 1568 37 Synchronous Belt N34646 Model Code "T"
33			1983	
34			2043	
35			2103	
36			2163	
37			2223	
38	44, 45	90cc - 110cc (5.4921ci - 6.71ci) 207679	2073	48 Top Sprocket N38492 37 Bottom Sprocket 203003 1568 37 Synchronous Belt N34646 Model Code "U"
39			2128	
40			2182	
41			2237	
42	44, 45	90cc - 110cc (5.4921ci - 6.71ci) 207679	2120	48 Top Sprocket N38492 40 Bottom Sprocket N38491 1568 37 Synchronous Belt N34646 Model Code "V"
43			2171	
44			2221	
45			2272	
46			2322	
47			2372	
48	44, 45	90cc - 110cc (5.4921ci - 6.71ci) 207679	2113	45 Top Sprocket N47578 43 Bottom Sprocket N34647 1568 37 Synchronous Belt N34646 Model Code "D"
49			2157	
50			2201	
51			2245	
52			2289	
53	44, 45	90cc - 110cc (5.4921ci - 6.71ci) 207679	2130	43 Top Sprocket N34647 45 Bottom Sprocket N47578 1568 37 Synchronous Belt N34646 Model Code "H"
54			2170	
55			2210	
56			2250	
57			2290	
58	44, 45	90cc - 110cc (5.4921ci - 6.71ci) 207679	2168	40 Top Sprocket N38491 45 Bottom Sprocket N47578 1568 37 Synchronous Belt N34646 Model Code "I"
59			2206	
60			2244	
61			2281	
62			2318	

(Charts continued on following page.)

Motor & Sprocket Selection Chart (Cont'd)

Loader Hydraulic System Pressure Chart

LOADER HYDRAULIC SYSTEM PRESSURE VARIABLE MOTORS	SETTING NUMBER
Muncie Motor (no setting available)	0
2800psi - 3499psi (Parker only)	1
3500psi - 3899psi (Parker only)	2
3900psi - 4399psi (Parker only)	3
4400psi - 5099psi (Parker only)	4
5100psi - 5999psi (Parker only)	5

NOTE: Consult factory for instructions to change threshold setting. Variable Motors arrive from factory at setting #2.

Fixed Displacement Motor (Muncie)

GPM	FIXED DISPLACEMENT MOTOR NUMBER MUNCIE	DISPLACEMENT LOFTNESS MOTOR NUMBER	ROTOR RPM	TOP SPROCKET (LOFTNESS NUMBER) BOTTOM SPROCKET (LOFTNESS NUMBER) BELT LENGTH (LOFTNESS NUMBER)
28	38	62.9cc (3.8383ci) N34676	1835	40 Top Sprocket N49227 36 Bottom Sprocket N49226 1400 20 Synchronous Belt N49223 Model Code "E"
29			1900	
30			1966	
31	38	62.9cc (3.8383ci) N34676	1828	38 Top Sprocket N49225 38 Bottom Sprocket N49225 1400 20 Synchronous Belt N49223 Model Code "F"
32			1887	
33			1946	
34			2005	
35			2064	
36	38	62.9cc (3.8383ci) N34676	1843	33 Top Sprocket N49224 38 Bottom Sprocket N49225 1400 20 Synchronous Belt N49223 Model Code "G"
37			1894	
38			1945	
39			1997	
40			2048	

Maintenance

Troubleshooting

PROBLEM	CAUSE	SOLUTION
Excessive Vibration	Broken or missing teeth.	Replace teeth.
	Mud and/or debris wrapped around the rotor.	Clean the Battle Ax.
	Faulty drive line bearing.	Replace bearing(s).
	Faulty rotor bearing.	Replace bearing(s).
	Damage to rotor (includes bent end of shafts, missing balance weights, or actual rotor deformity from striking rocks, etc.)	Consult factory.
Uneven Cutting	Teeth dull or worn excessively.	Replace teeth.
	Engine RPM too slow.	Adjust machine RPM to full throttle.
	Travel speed too fast.	Reduce ground speed.
Rotor Will Not Turn	Faulty drive line bearing.	Replace bearing(s).
	Faulty rotor bearing.	Replace bearing(s).
	Belt damaged.	Replace belt.
	Belt slipping.	Clean or replace belt.
		Adjust tension.
Oil Leak At Hydraulic Control Valve Cover.	Pinched case drain hose.	Check hose.
	Disconnected case drain hose.	Reconnect hose.



PARTS IDENTIFICATION

Parts Identification

Battle Ax S Series Covers and Skids

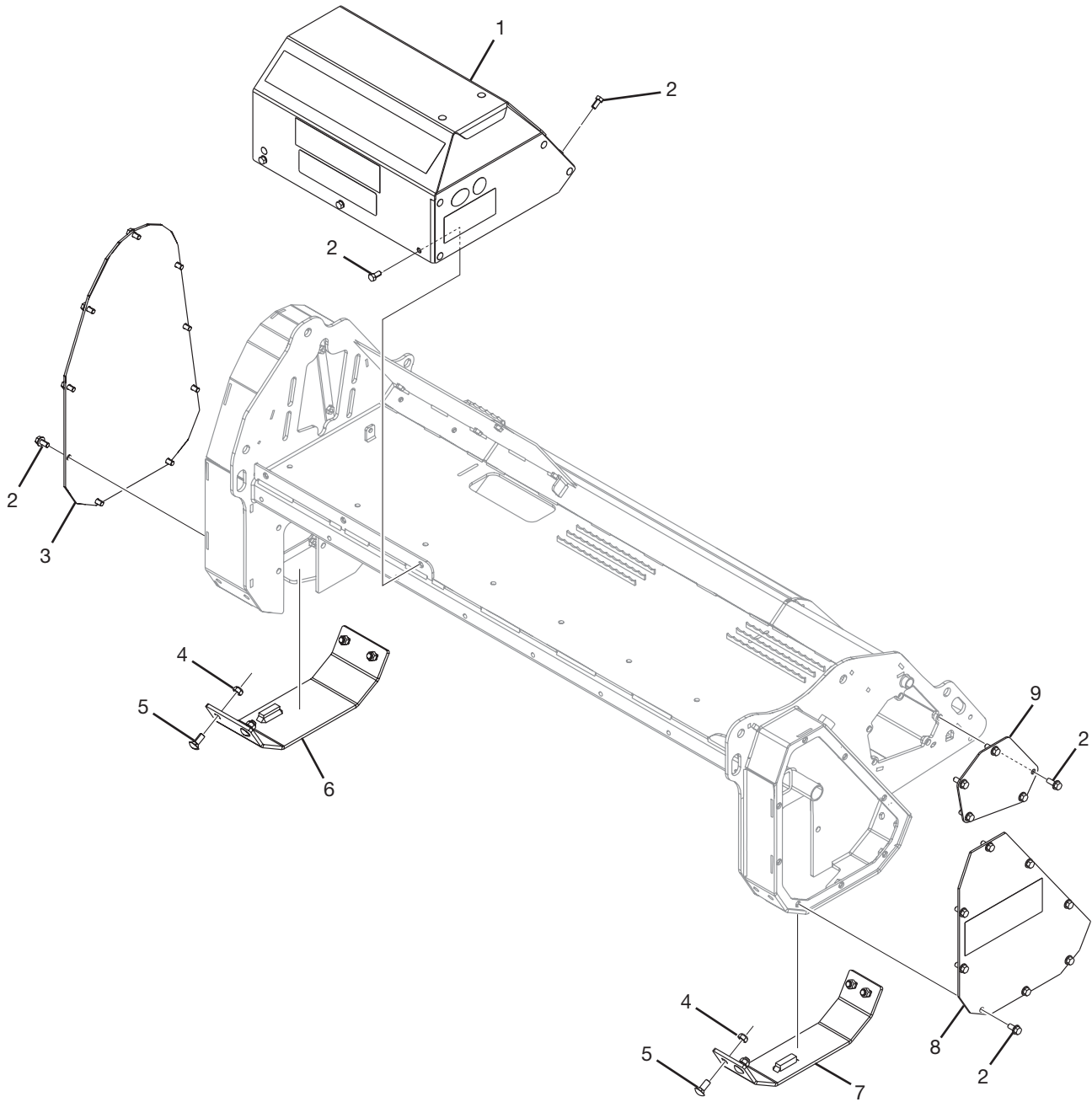

* Parts breakdown of item 1, Motor Shield (209519) is on page 36.

Battle Ax S Series Covers and Skids

#	QTY.	PART #	DESCRIPTION
1	1	209519	SHIELD, MOTOR
2	29	N26748	BOLT, 1/2" X 1" SER FLG
3	1	209514	PLATE, BELT COVER
4	8	4055	NUT, LOCK 5/8" TOP
5	8	4386	BOLT, CARRIAGE 5/8" X 1-1/2"
6	1	206995	PLATE, SKID W/BRACE
7	1	209016	SKID, W/BRACE DRIVEN
8	1	206990	PLATE, BEARING COVER
9	1	209011	PLATE, VALVE COVER

Parts Identification

Shield, Motor (209519)

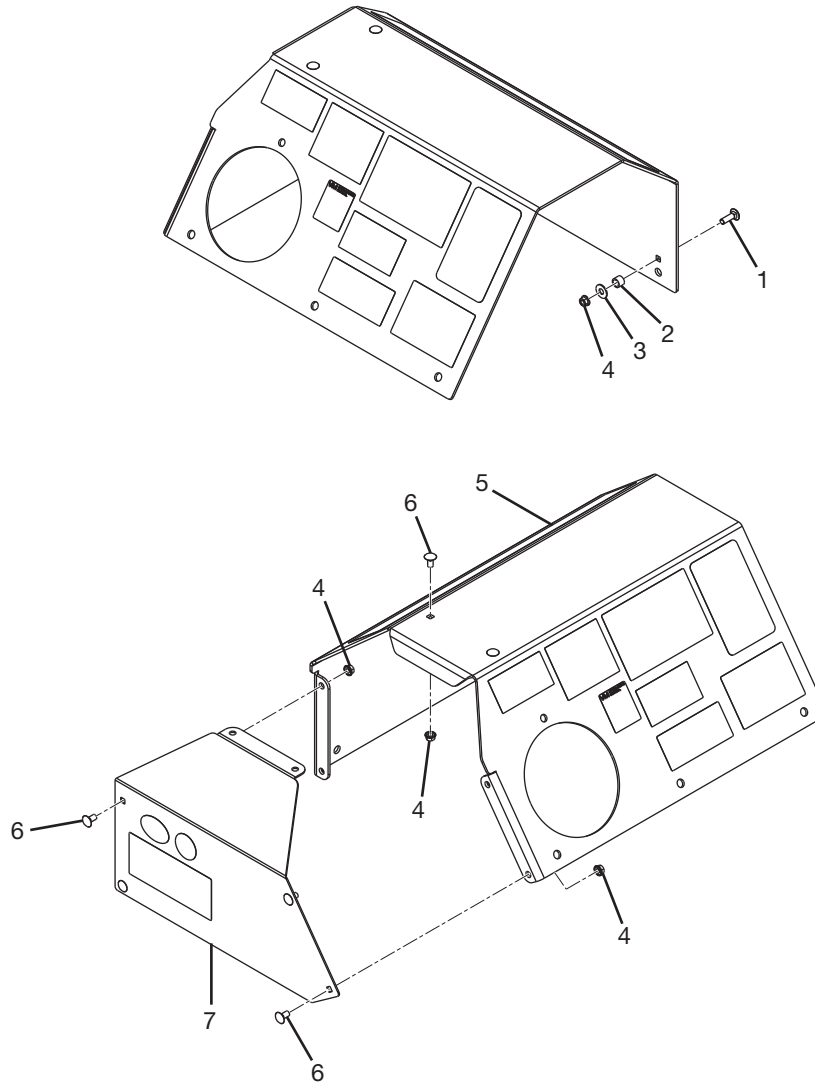

#	QTY.	PART #	DESCRIPTION
1	1	4390	BOLT, 3/8" X 1-1/4" CARRIAGE
2	1	209515	BUSHING, GUIDE
3	1	4064	WASHER, FLAT 3/8"
4	7	4979	NUT, LOCK 3/8" SER FLG
5	1	209518	COVER, MOTOR TOP W/ DECALS
6	6	4033	BOLT, CARRIAGE 3/8" X 3/4" GR5
7	1	209517	COVER, MOTOR END W/ DECALS

Battle Ax S Series Deflector Chains, Stands, and Belt Adjustment

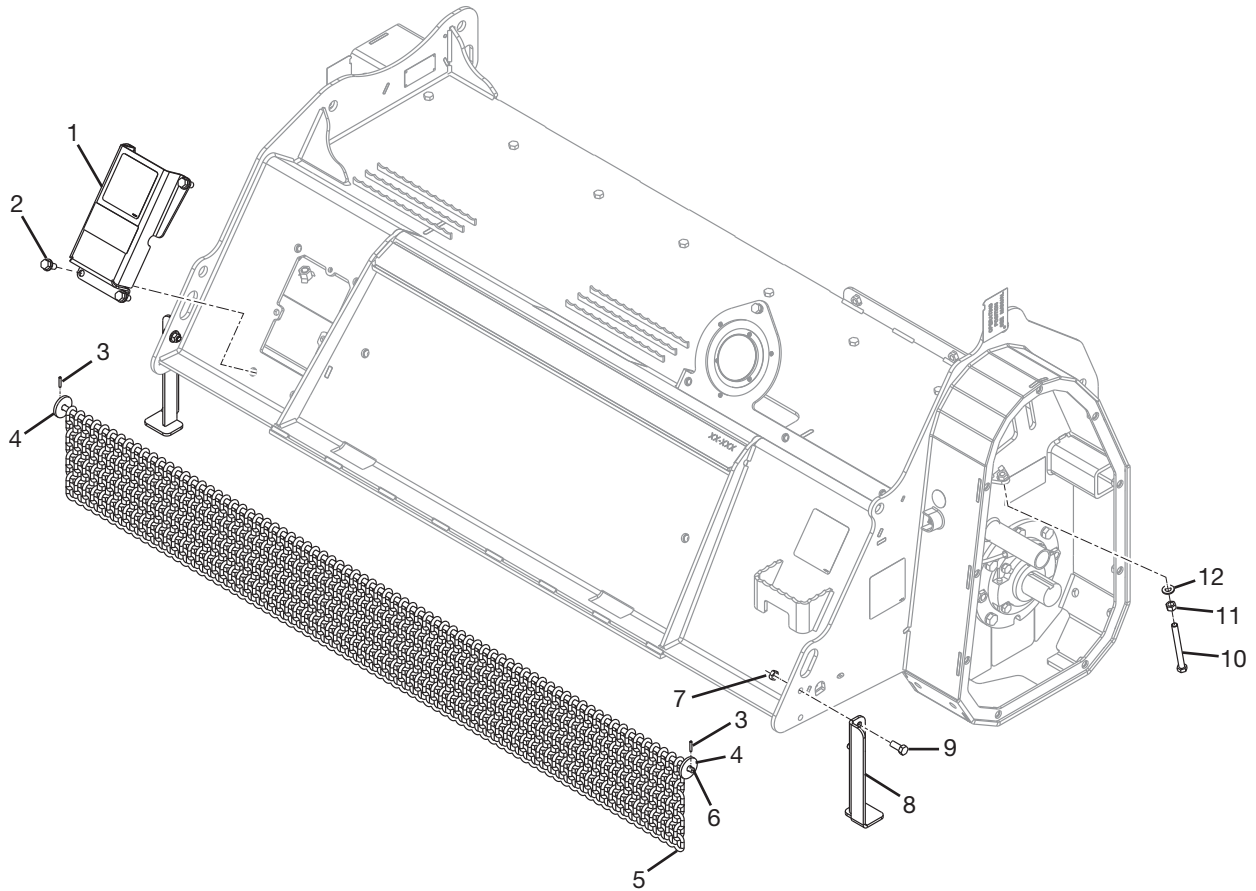

#	QTY.	PART #	DESCRIPTION
1	1	N68396	COVER, HOSE W/DECALS
2	4	N26748	BOLT, 1/2" X 1" SER FLG
3	2	4375	PIN, ROLL 3/16" X 1"
4	2	4074	WASHER, 2" OD X 1/2" ID X 1/4"
5	66	N15589	CHAIN, CARBIDE AX REAT (61")
	76	N15589	(71")
6	1	209017	ROD, CARBIDE 61 CHAIN
7	4	4054	NUT, LOCK 1/2" TOP
8	2	206993	STAND, SHIPPING W/ DECAL
9	4	4012	BOLT, 1/2" X 1-1/4" GRADE 5
10	1	N27483	BOLT, 1/2" X 5" GR 5 FL TH
11	1	4250	NUT, STANDARD 1/2
12	4	4068	WASHER, 1/2" SAE FLAT

Parts Identification

Battle Ax S Series Cutter and Re-Cutter Bars

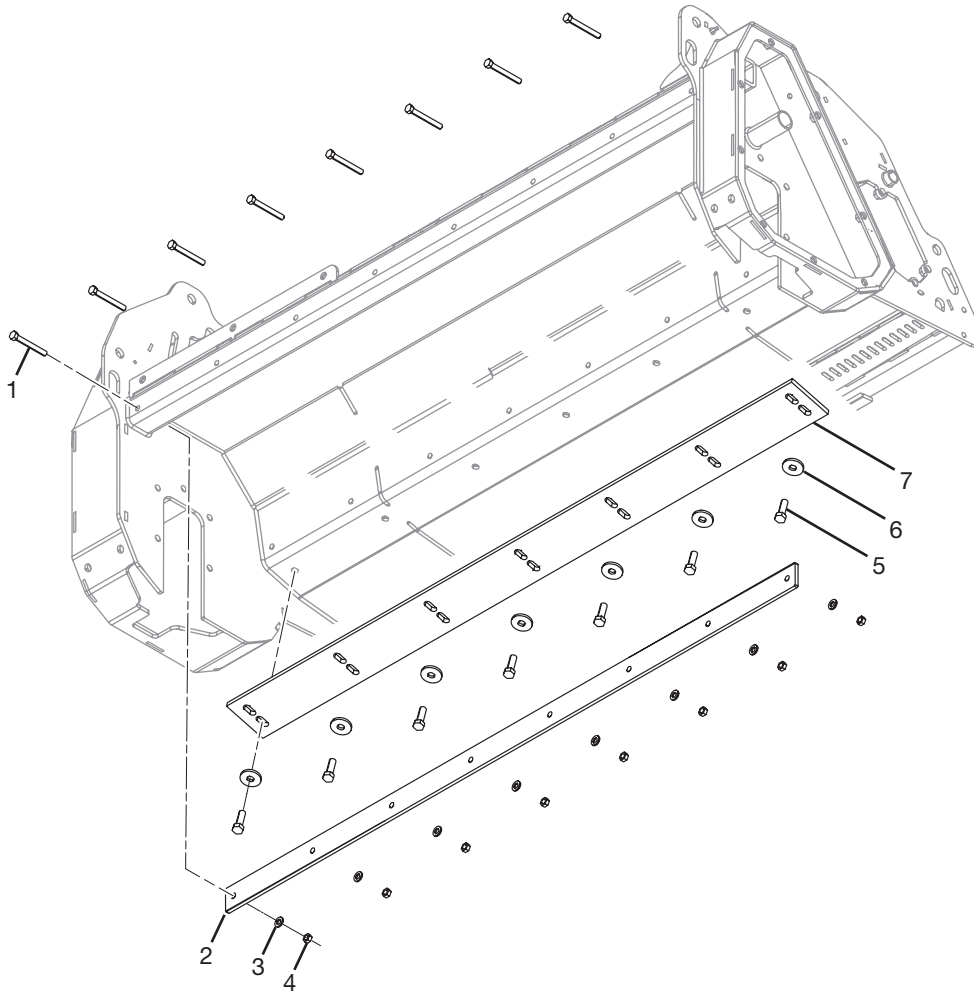

#	QTY.	PART #	DESCRIPTION
1	7	4975	BOLT, 1/2" X 4" FN TH GR 8 (61")
	8	4975	(71")
2	1	209037	RECUTTER, BOLT-IN 61
	1	209038	RECUTTER, BOLT-IN 71
3	7	N37780	WASHER, NORD-LOCK 1/2" SP (61")
	8	N37780	(71")
4	7	4503	NUT, STANDARD 1/2" FN THD GR 8 (61")
	8	4503	(71")
5	7	4042	BOLT, 5/8" X 2" FINE THRD. GR.8
6	7	208800	WASHER, 2.000D X .688ID X .25T
7	1	N38534	PLATE, RECUTTER (61")
	1	N41754	PLATE, RECUTTER (71")

Pusher

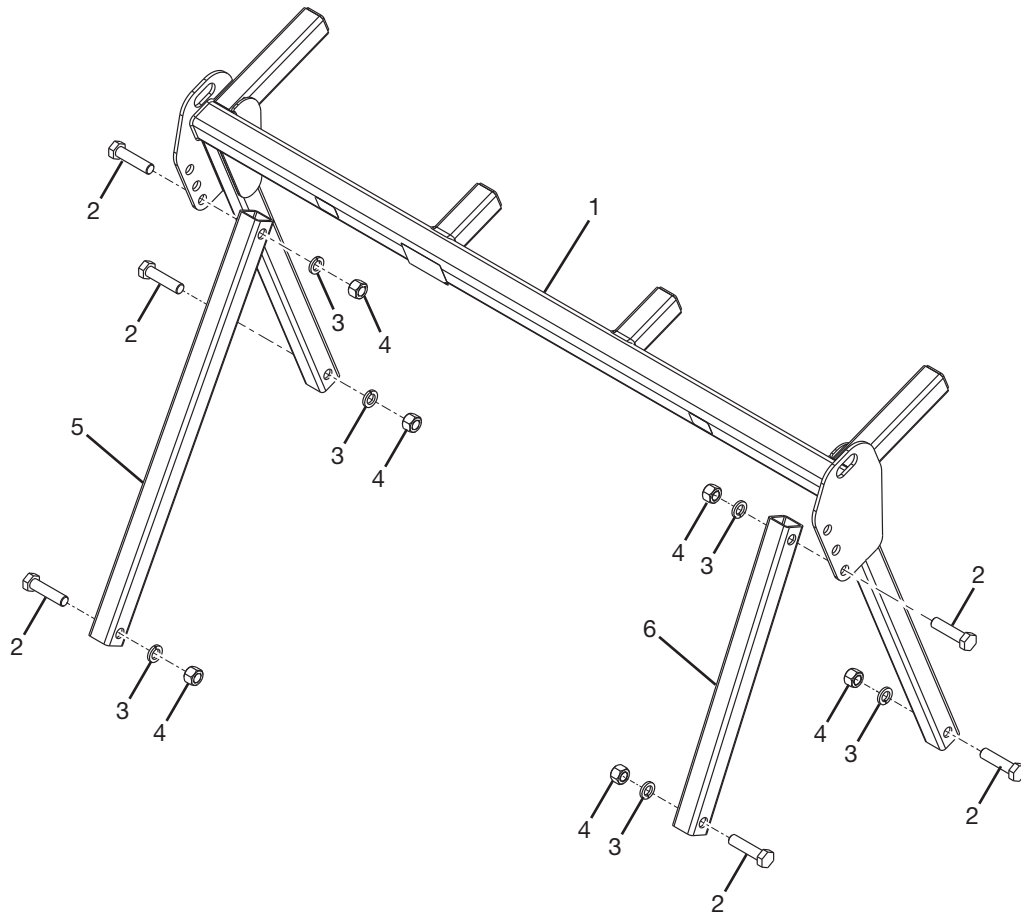

#	QTY.	PART #	DESCRIPTION
1	1	N38523	PUSHER, 61 W/DECALS
	1	N68438	PUSHER, 71 W/DECALS
2	6	N64492	BOLT, 1-14 X 4" GR. 8 FN. THR
3	6	4166	WASHER, 1" LOCK
4	6	4490	NUT, 1"-14UNF STANDARD
5	1	N67081	TUBE, PUSHER LONG W/BUSHING
6	1	N67045	TUBE, PUSHER SHORT W/BUSHING

Parts Identification

Belt and Sprocket Options

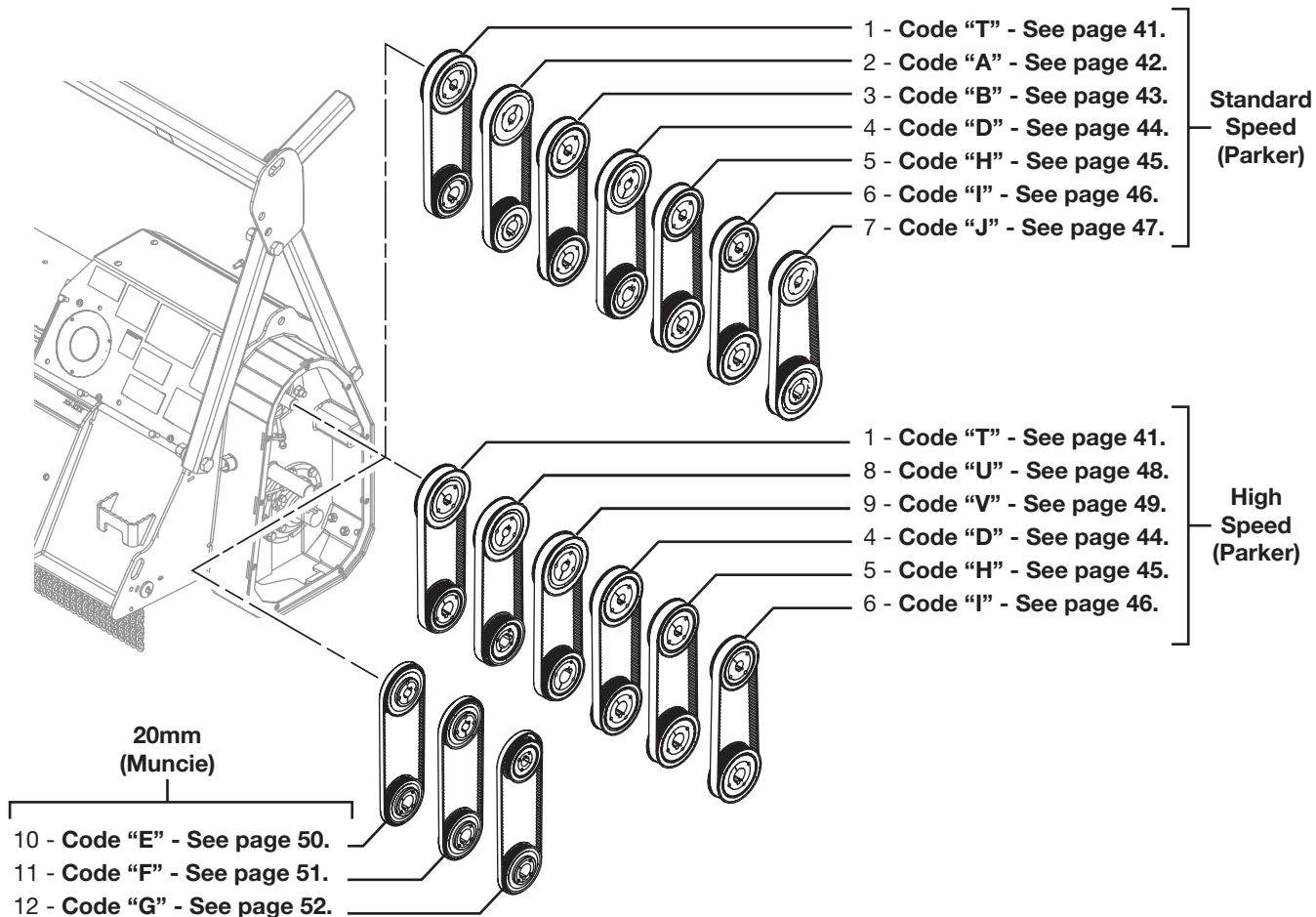

#	QTY.	PART #	DESCRIPTION
1	1	203173	BELT ASSY, 37MM T
2	1	N80411	BELT ASSY, 37MM A
3	1	N80392	BELT ASSY, 37MM B
4	1	N132294	BELT ASSY, 37MM D
5	1	208314	BELT ASSY, 37MM H
6	1	208315	BELT ASSY, 37MM I
7	1	208316	BELT ASSY, 37MM J
8	1	203174	BELT ASSY, 37MM U
9	1	203175	BELT ASSY, 37MM V
10	1	N132298	BELT ASSY, 20MM E
11	1	N132300	BELT ASSY, 20MM F
12	1	N132302	BELT ASSY, 20MM G

Parts Identification

Belt Assembly, 50T 35B 37MM 1568 - Code "T" (203173)

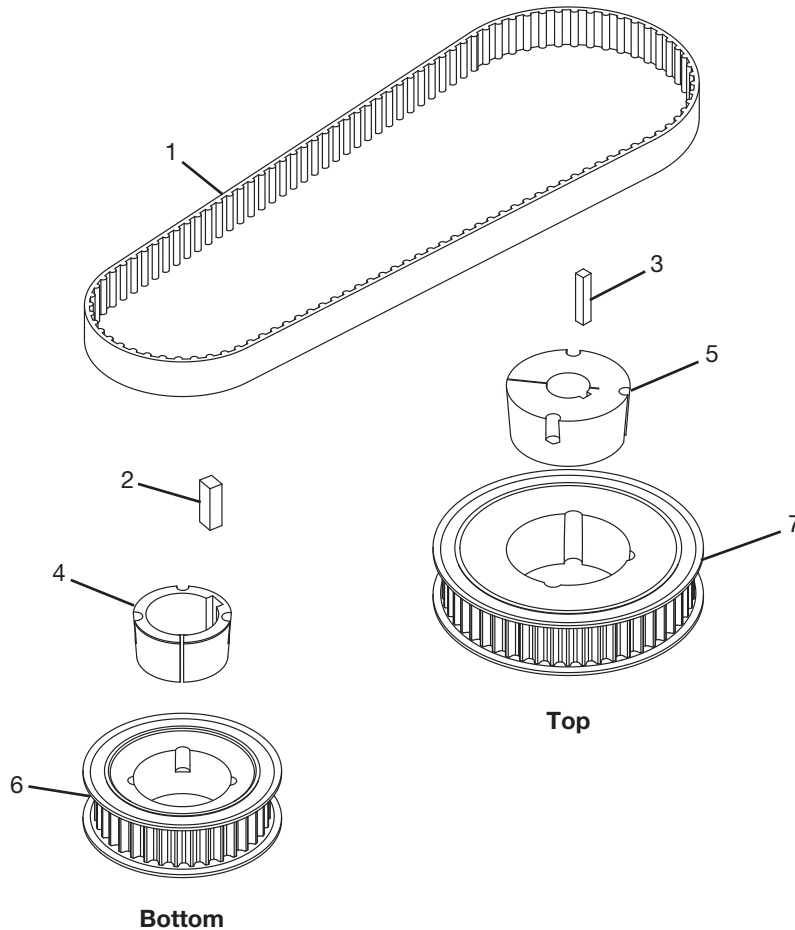

#	QTY.	PART #	DESCRIPTION
1	1	N34646	BELT, POLY CHAIN 14MM 1568 X 37
2	1	7122-04	KEY, 1/2" X 2"
3	1	7121-03	KEY, 3/8" X 2"
4	1	8165	BUSHING, 2-3/16 TPL 2517
5	1	N20805	BUSHING, 1-1/2" TPL 3020
6	1	203001	SPROCKET, 14MM 35 TOOTH 37
7	1	N38471	SPROCKET, 14MM 50 TOOTH 37

Parts Identification

Belt Assembly, 48T 38B 37MM 1568 - Code "A" (N80411)

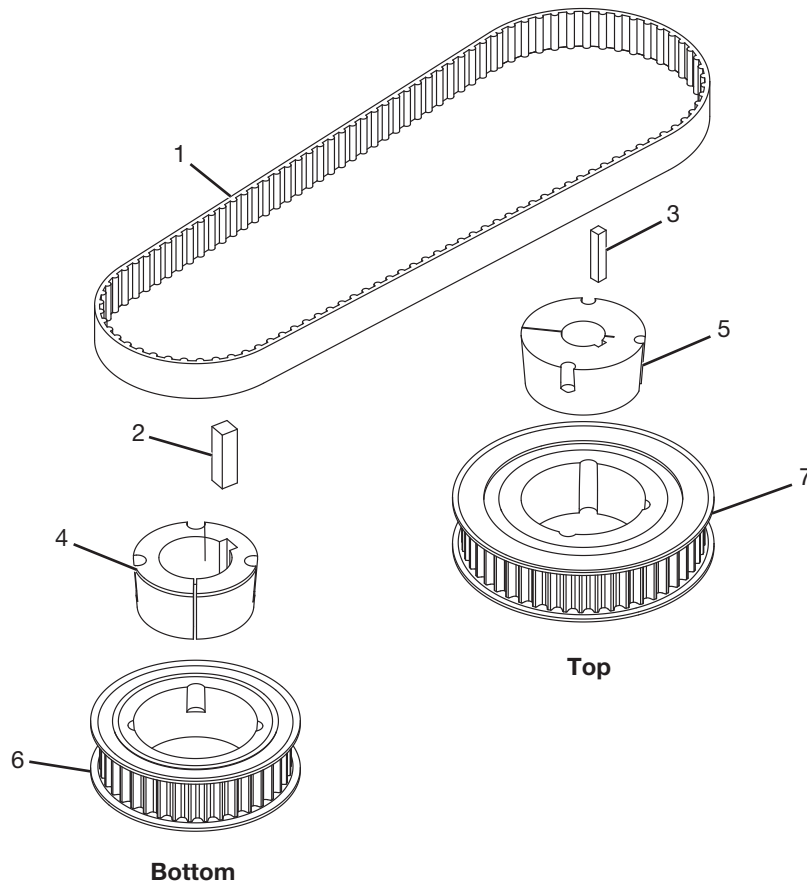

#	QTY.	PART #	DESCRIPTION
1	1	N34646	BELT, POLY CHAIN 14MM 1568 X 37
2	1	7122-04	KEY, 1/2" X 2"
3	1	7121-03	KEY, 3/8" X 2"
4	1	N18975	BUSHING, 2 3/16 TPL 3020
5	1	N20805	BUSHING, 1-1/2" TPL 3020
6	1	N38490	SPROCKET, 14MM 38 TOOTH 37
7	1	N38492	SPROCKET, 14MM 48 TOOTH 37

Parts Identification

Belt Assembly, 45T 40B 37MM 1568 - Code "B" (N80392)

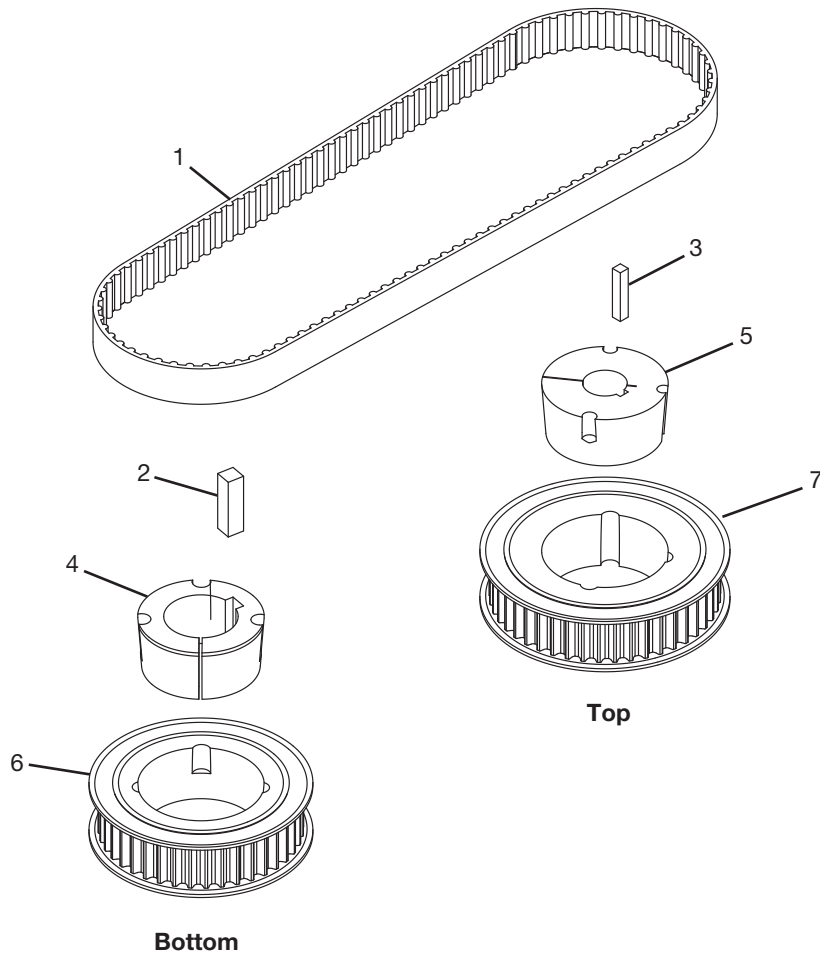

#	QTY.	PART #	DESCRIPTION
1	1	N34646	BELT, POLY CHAIN 14MM 1568 X 37
2	1	7122-04	KEY, 1/2" X 2"
3	1	7121-03	KEY, 3/8" X 2"
4	1	N18975	BUSHING, 2 3/16 TPL 3020
5	1	N20805	BUSHING, 1-1/2" TPL 3020
6	1	N38491	SPROCKET, 14MM 40 TOOTH 37
7	1	N47578	SPROCKET, 14MM 45 TOOTH 37

Parts Identification

Belt Assembly, 45T 43B 37MM 1568 - Code "D" (N132294)

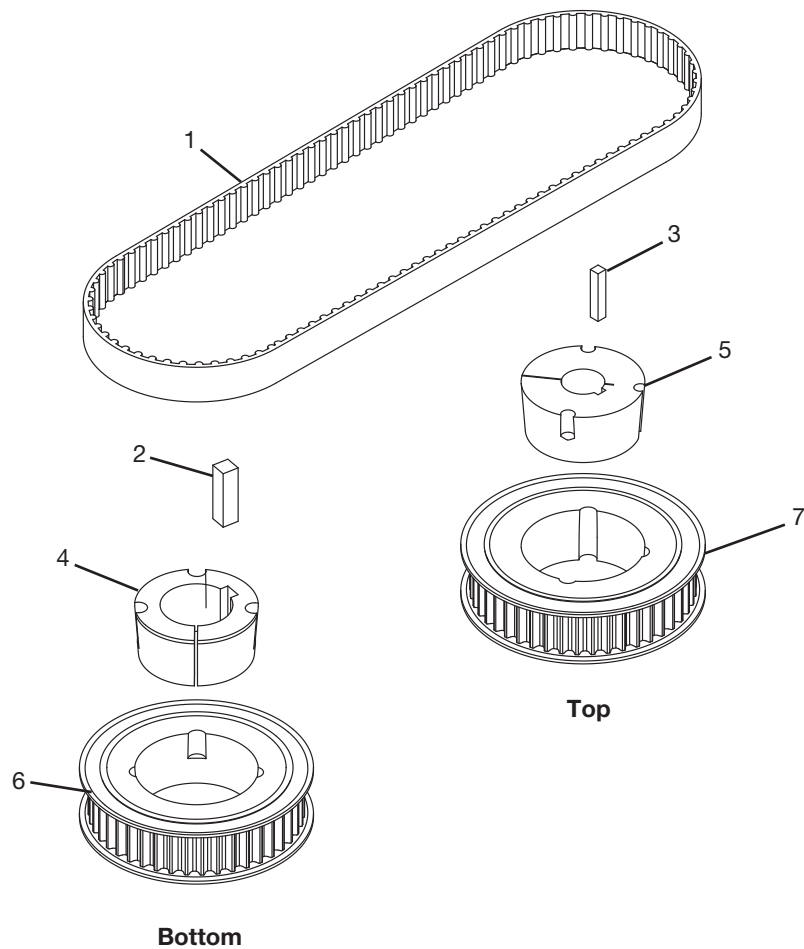

#	QTY.	PART #	DESCRIPTION
1	1	N34646	BELT, POLY CHAIN 14MM 1568 X 37
2	1	7122-04	KEY, 1/2" X 2"
3	1	7121-03	KEY, 3/8" X 2"
4	1	N18975	BUSHING, 2 3/16 TPL 3020
5	1	N20805	BUSHING, 1-1/2" TPL 3020
6	1	N34647	SPROCKET, 14MM 43 TOOTH 37
7	1	N47578	SPROCKET, 14MM 45 TOOTH 37

Parts Identification

Belt Assembly, 43T 45B 37MM 1568 - Code "H" (208314)

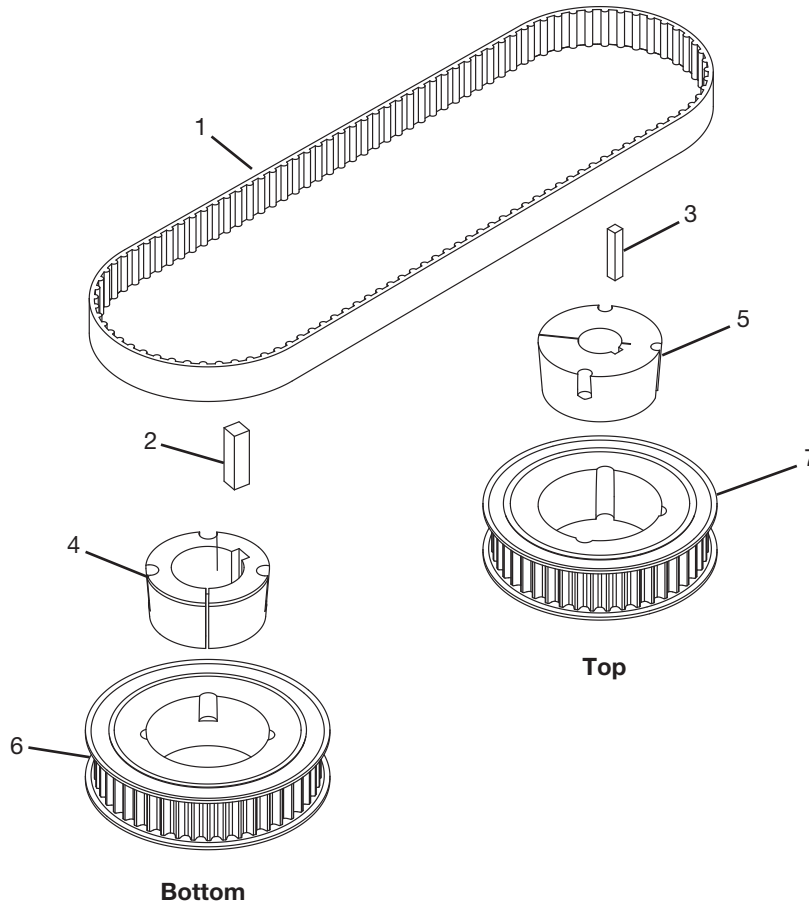

#	QTY.	PART #	DESCRIPTION
1	1	N34646	BELT, POLY CHAIN 14MM 1568 X 37
2	1	7122-04	KEY, 1/2" X 2"
3	1	7121-03	KEY, 3/8" X 2"
4	1	N18975	BUSHING, 2 3/16 TPL 3020
5	1	N20805	BUSHING, 1-1/2" TPL 3020
6	1	N47578	SPROCKET, 14MM 45 TOOTH 37
7	1	N34647	SPROCKET, 14MM 43 TOOTH 37

Parts Identification

Belt Assembly, 40T 45B 37MM 1568 - Code "I" (208315)

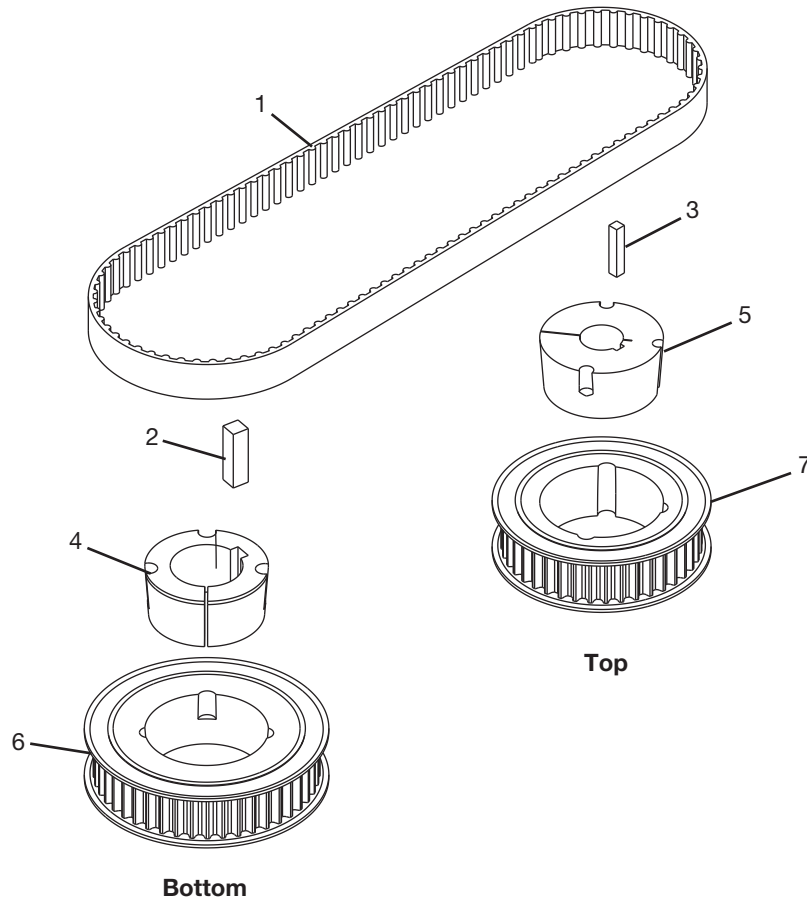

#	QTY.	PART #	DESCRIPTION
1	1	N34646	BELT, POLY CHAIN 14MM 1568 X 37
2	1	7122-04	KEY, 1/2" X 2"
3	1	7121-03	KEY, 3/8" X 2"
4	1	N18975	BUSHING, 2 3/16 TPL 3020
5	1	N20805	BUSHING, 1-1/2" TPL 3020
6	1	N47578	SPROCKET, 14MM 45 TOOTH 37
7	1	N38491	SPROCKET, 14MM 40 TOOTH 37

Parts Identification

Belt Assembly, 40T 48B 37MM 1568 - Code "J" (208316)

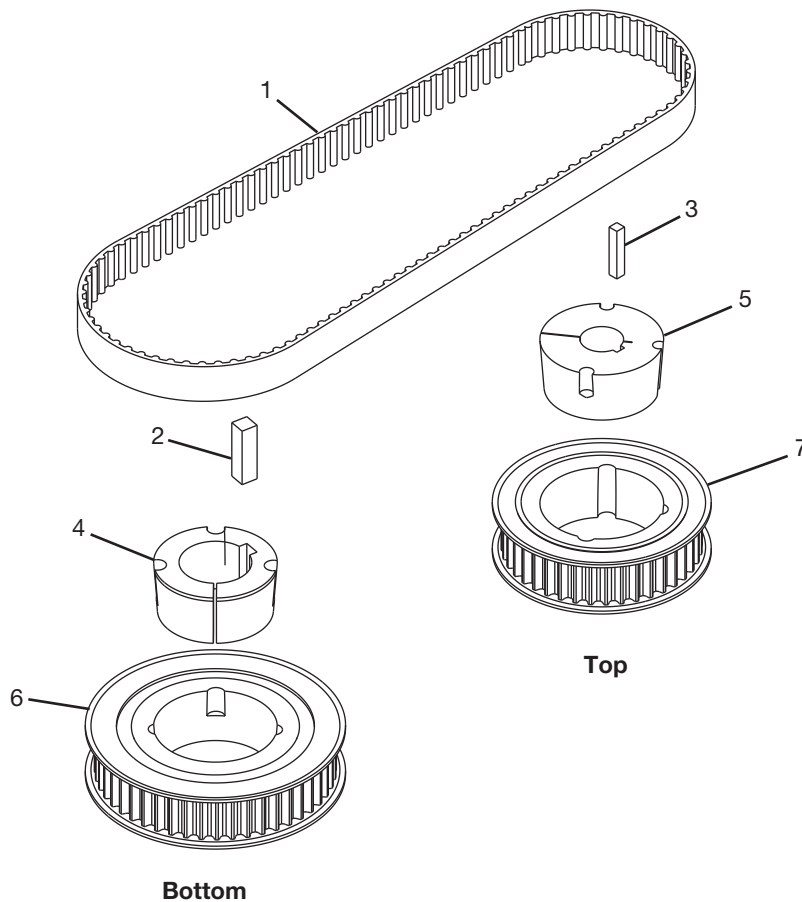

#	QTY.	PART #	DESCRIPTION
1	1	N34646	BELT, POLY CHAIN 14MM 1568 X 37
2	1	7122-04	KEY, 1/2" X 2"
3	1	7121-03	KEY, 3/8" X 2"
4	1	N18975	BUSHING, 2 3/16 TPL 3020
5	1	N20805	BUSHING, 1-1/2" TPL 3020
6	1	N38492	SPROCKET, 14MM 48 TOOTH 37
7	1	N38491	SPROCKET, 14MM 40 TOOTH 37

Parts Identification

Belt Assembly, 48T 37B 37MM 1568 - Code "U" (203174)

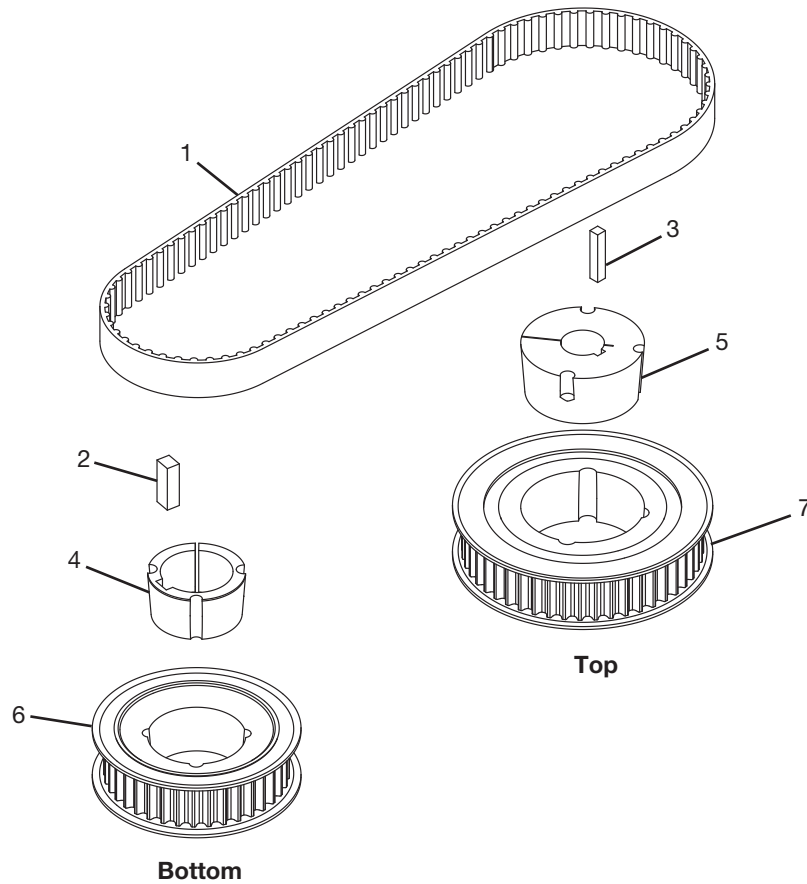

#	QTY.	PART #	DESCRIPTION
1	1	N34646	BELT, POLY CHAIN 14MM 1568 X 37
2	1	7122-04	KEY, 1/2" X 2"
3	1	7121-03	KEY, 3/8" X 2"
4	1	8165	BUSHING, 2-3/16 TPL 2517
5	1	N20805	BUSHING, 1-1/2" TPL 3020
6	1	203003	SPROCKET, 14MM 37 TOOTH 37
7	1	N38492	SPROCKET, 14MM 48 TOOTH 37

Parts Identification

Belt Assembly, 48T 40B 37MM 1568 - Code "V" (203175)

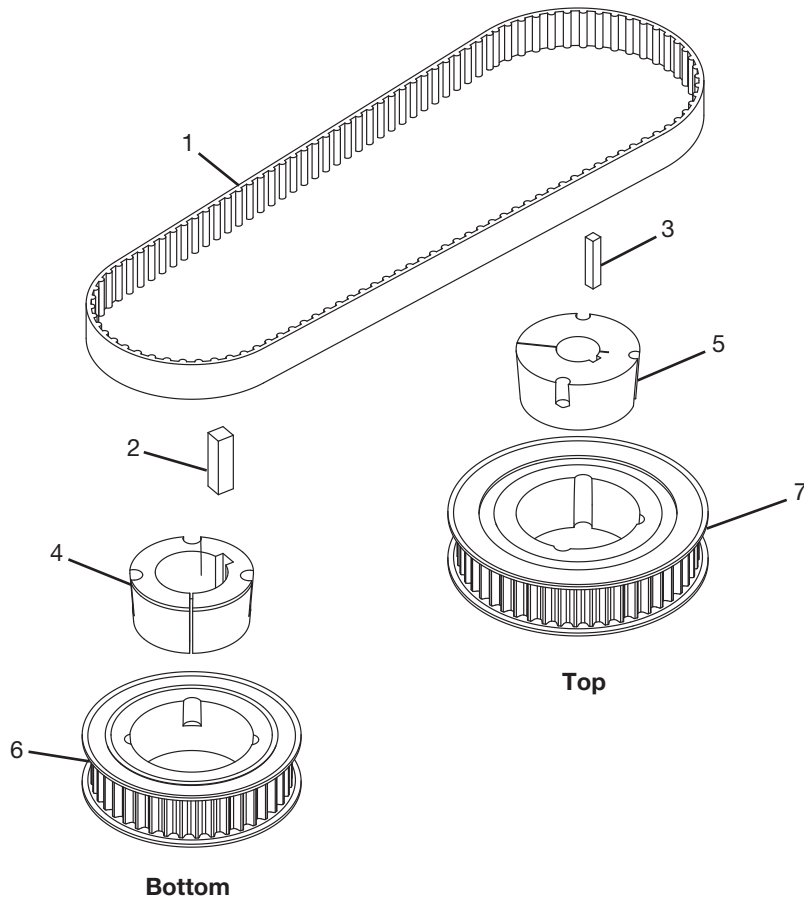

#	QTY.	PART #	DESCRIPTION
1	1	N34646	BELT, POLY CHAIN 14MM 1568 X 37
2	1	7122-04	KEY, 1/2" X 2"
3	1	7121-03	KEY, 3/8" X 2"
4	1	N18975	BUSHING, 2 3/16 TPL 3020
5	1	N20805	BUSHING, 1-1/2" TPL 3020
6	1	N38491	SPROCKET, 14MM 40 TOOTH 37
7	1	N38492	SPROCKET, 14MM 48 TOOTH 37

Parts Identification

Belt Assembly, 40T 36B 20MM 1400 - Code "E" (N132298)

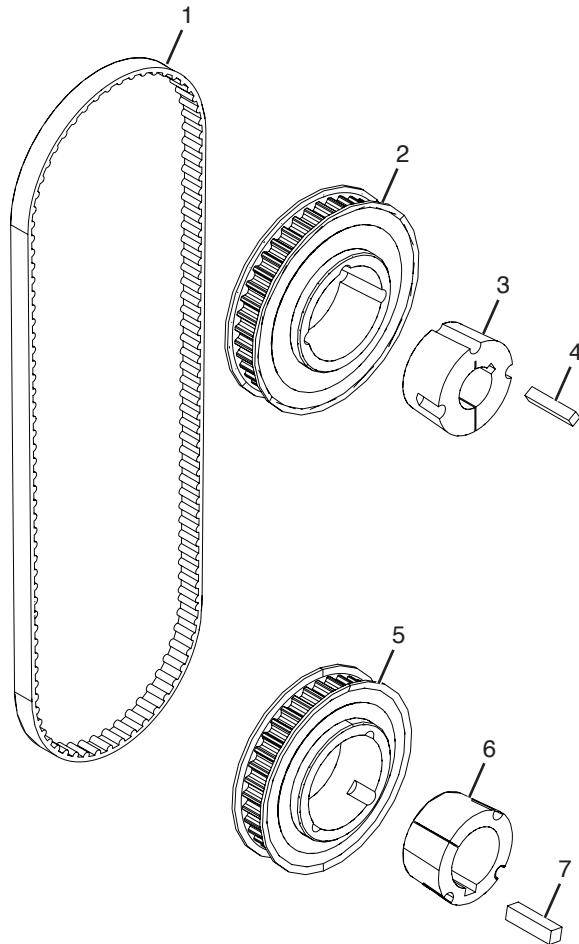

#	QTY.	PART #	DESCRIPTION
1	1	N49223	BELT, POLY CHAIN 1400 X 20MM
2	1	N49227	SPROCKET, 14MM 40 TOOTH 20MM
3	1	8126	BUSHING, 1-1/2 TAPERLOCK KEYED
4	1	7121-03	KEY, 3/8 X 2
5	1	N49226	SPROCKET, 14MM 36 TOOTH 20MM
6	1	8165	BUSHING, 2-3/16 TAPERLOCK KEYED
7	1	7122-04	KEY 1/2 X 2

Parts Identification

Belt Assembly, 38T 38B 20MM 1400 - Code "F" (N132300)

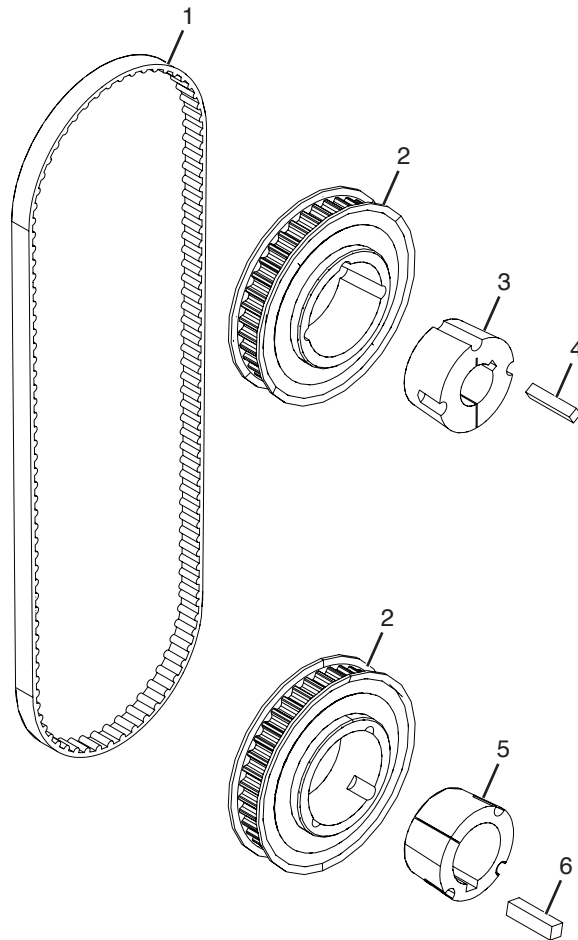

#	QTY.	PART #	DESCRIPTION
1	1	N49223	BELT, POLY CHAIN 1400 X 20MM
2	2	N49225	SPROCKET, 14MM 38 TOOTH 20MM
3	1	8126	BUSHING, 1-1/2 TAPERLOCK KEYED
4	1	7121-03	KEY, 3/8 X 2
5	1	8165	BUSHING, 2-3/16 TAPERLOCK KEYED
6	1	7122-04	KEY 1/2 X 2

Parts Identification

Belt Assembly, 33T 38B 20MM 1400 - Code "G" (N132302)

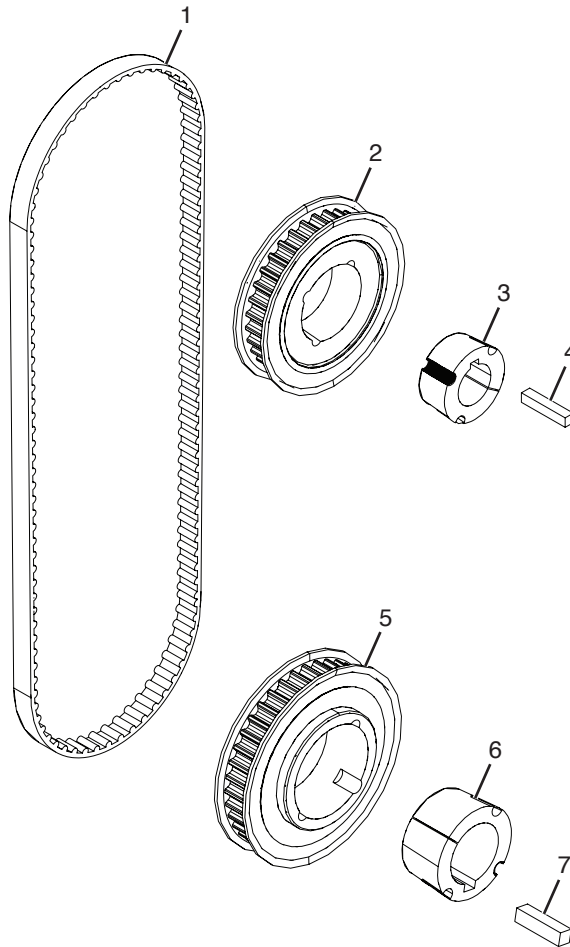

#	QTY.	PART #	DESCRIPTION
1	1	N49223	BELT, POLY CHAIN 1400 X 20MM
2	1	N49224	SPROCKET, 14MM 33 TOOTH 20MM
3	1	N49228	BUSHING, 1-1/2 TAPERLOCK KEYED
4	1	7121-03	KEY, 3/8 X 2
5	1	N49225	SPROCKET, 14MM 38 TOOTH 20MM
6	1	8165	BUSHING, 2-3/16 TAPERLOCK KEYED
7	1	7122-04	KEY 1/2 X 2

Gauge, Pressure

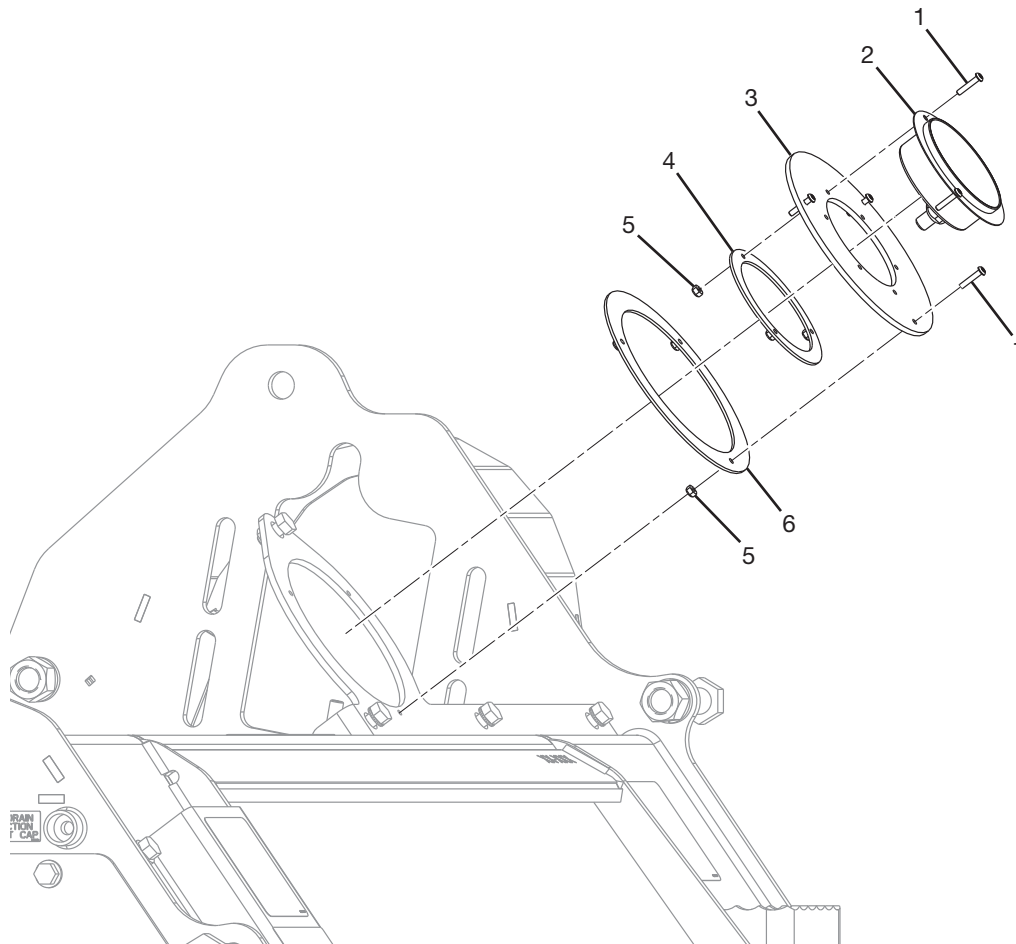

#	QTY.	PART #	DESCRIPTION
1	6	N16333	BOLT, BHCS #10-32 X 1
2	1	205041	GAUGE, 0-6000 PSI 4IN PRESS
3	1	N16332	FLANGE, MOUNT GAUGE
4	1	N16331	FLANGE, MOUNT GAUGE #8
5	6	N16334	NUT, NYLON INSERT #10
6	1	N16335	FLANGE, MOUNT #10

Parts Identification

Hydraulics, Parker Motor No Brake (209063)

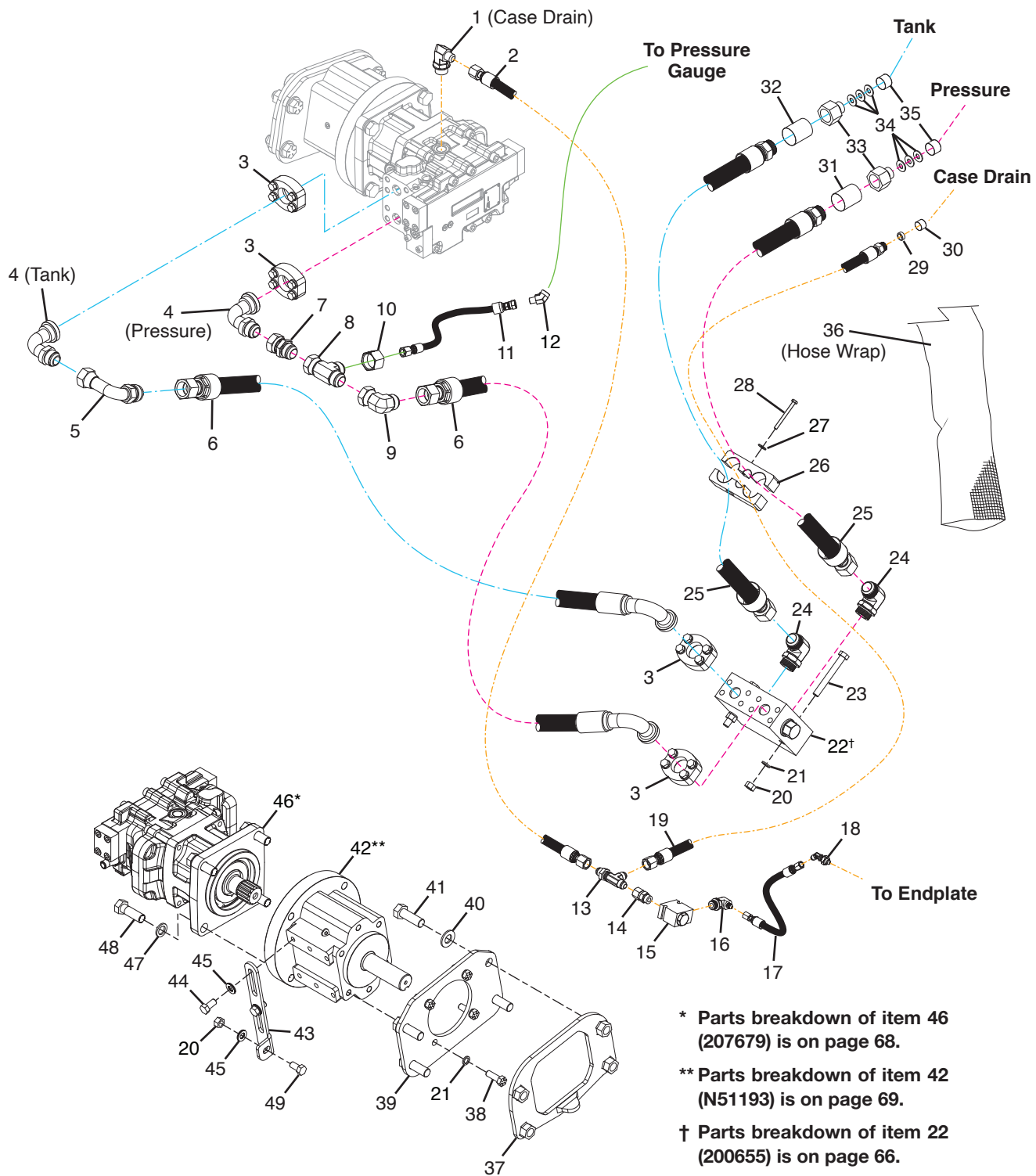

Parts Identification

Hydraulics, Parker Motor No Brake (209063)

#	QTY.	PART #	DESCRIPTION
1	1	N26333	ELBOW, 90 DEG - 8MJC - 12MOR
2	1	N38500	HOSE, 1/2 80 -8FJIC -8FJIC
3	4	N20288	KIT, SPLIT FLANGE SFXK-16
4	2	N20818	ELBOW, 90DEG 16MJIC-16 CODE 62
5	1	N28903	ELBOW, 90DG TUBE 16MJIC-16FJIC
6	2	N90323	HOSE, 1 X 64 -16FJIC-16CD62 90
7	1	N19271	ADAPTER, 16MJIC - 16FJIC SWVL
8	1	N19272	TEE, 16MJIC-16FJIC-16MJIC
9	1	N19270	ELBOW, 90 DEG - 16MJC - 16FJC
10	1	N30420	ADAPTER, -16MJIC -6MJIC
11	1	209526	HOSE, 1/4 X 16 -4FPSW -6FJIC
12	1	209543	ELBOW, 1/4" BLK 45 DEG STREET
13	1	200882	BULKHEAD, TEE RUN -8
14	1	N24835	ADAPTER, 8MOR - 8FJIC
15	1	N157054	VALVE, RELIEF 100PSI
16	1	N38520	ADAPTER, 90 -4MJIC -8MORB
17	1	N69021	HOSE, 1/4 X 14 -4FJIC -4FJIC
18	1	N38519	BULKHEAD, 45DEG -4MJIC-4MJIC
19	1	N90142	HOSE, 1/2 100 -8FJIC -8MORB
20	3	4250	NUT, STANDARD 1/2
21	6	N16472	WASHER, 1/2 NORDLOCK
22	1	200655	MANIFOLD, RELIEF 5000PSI,CHECK
23	2	4154	BOLT, 1/2" X 3-1/2" GR 5
24	2	N41121	ELBOW, 90 DEG -16MJIC-16MOR
25	2	N90130	HOSE, 1 84 -16FJIC -16MORB
26	2	207128	CLAMP, HOSE HI-PRESSURE
27	1	3183	WASHER, FLAT 1/4"
28	1	N13811	BOLT, 1/4" X 2-3/4" GRADE 5
29	1	N32002	PLUG, 3/8 SCH 40 X .25
30	1	N15895	CAP, 1/2 ALUMINUM HOSE
31	1	N24822	DECAL, PRESSURE
32	1	N24823	DECAL, RETURN
33	2	N28108	ADAPTER, - 12MOR - 16FOR
34	6	4064	WASHER, FLAT 3/8"

Parts Identification

Hydraulics, Parker Motor No Brake (209063) (Cont'd)

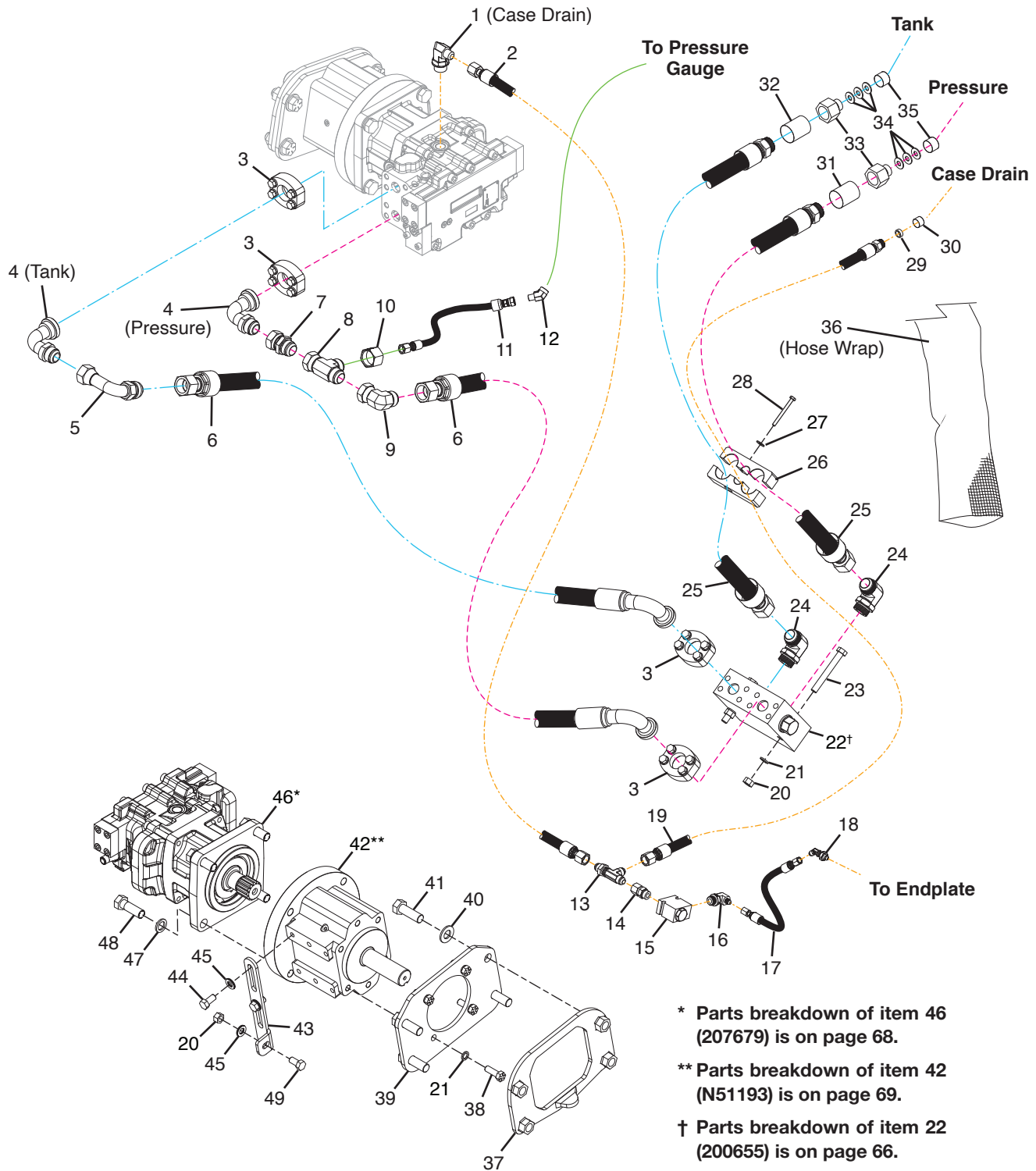

* Parts breakdown of item 46 (207679) is on page 68.

** Parts breakdown of item 42 (N51193) is on page 69.

† Parts breakdown of item 22 (200655) is on page 66.

Parts Identification

Hydraulics, Parker Motor No Brake (209063) (Cont'd)

#	QTY.	PART #	DESCRIPTION
35	2	N15893	CAP, 3/4 ALUMINUM HOSE
36	1	N90265	WRAP, HOSE 76
37	1	209068	PLATE, WELDMENT MOTOR
38	4	4466	BOLT, 1/2" X 1-1/2" GRADE 8
39	1	209072	PLATE, MOUNT MOTOR
40	4	N28567	WASHER, 3/4 NORDLOCK SP
41	4	4343	BOLT, 3/4" X 2-1/4" FN TH GR 8
42	1	N51193	OHLA, 900 W C TO D ADAPTER
43	1	N49792	PLATE, SUPPORT MOTOR ASSY
44	2	4011	BOLT, 1/2" X 1" GRADE 5
45	3	N37780	WASHER, NORD-LOCK 1/2" SP
46	1	207679	MOTOR, VARIABLE 90CC-110CC
47	4	N16474	WASHER, 3/4 NORDLOCK
48	4	208781	BOLT, 3/4IN X 2-1/4IN UNC GR 8
49	1	4012	BOLT, 1/2" X 1-1/4" GR 5

Parts Identification

Hydraulics, Parker Motor Closed Loop Flushing (209062)

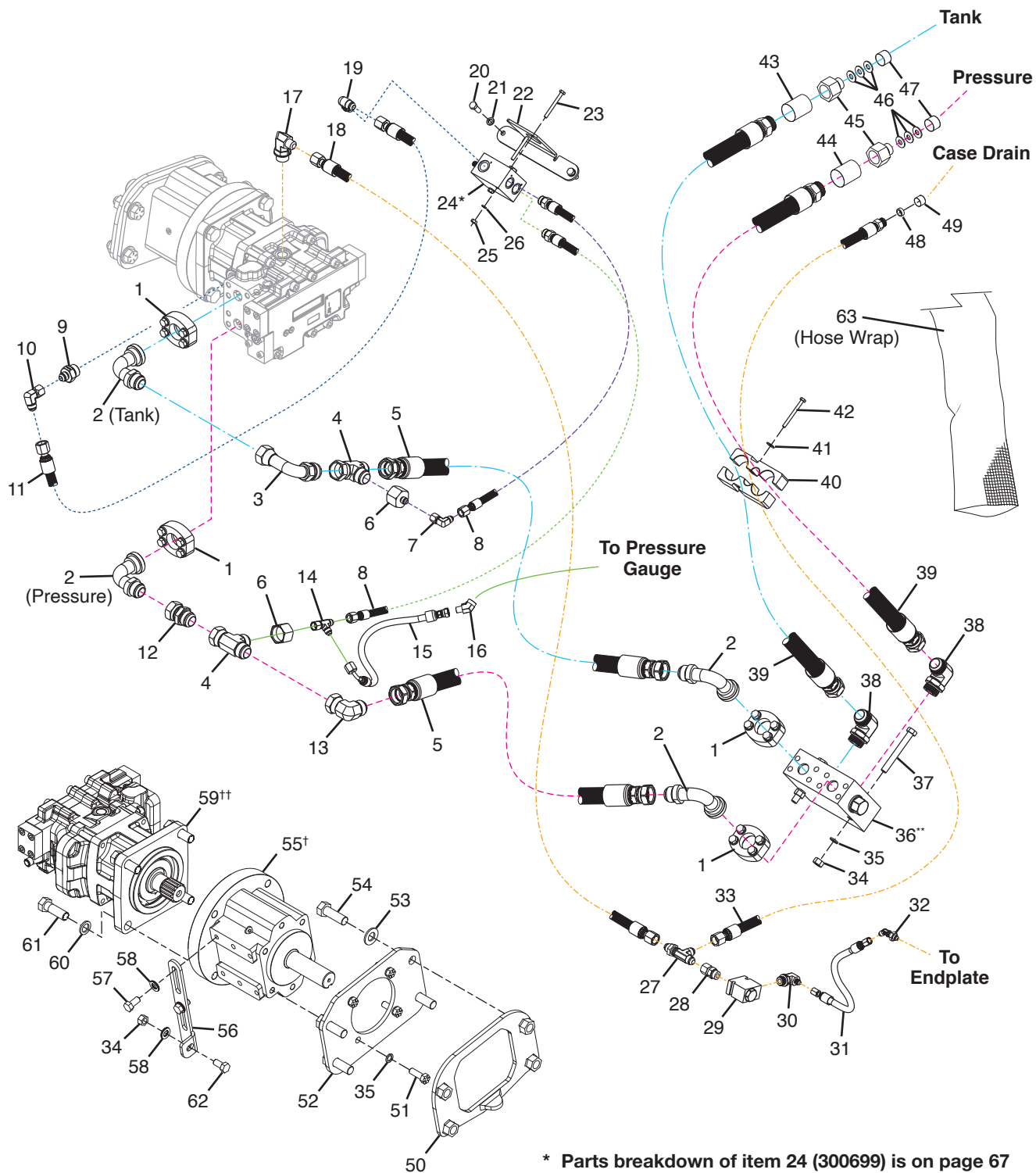

* Parts breakdown of item 24 (300699) is on page 67
 ** Parts breakdown of item 36 (200655) is on page 66.
 † Parts breakdown of item 55 (N51193) is on page 69.
 †† Parts breakdown of item 59 (207679) is on page 68.

Parts Identification

Hydraulics, Parker Motor Closed Loop Flushing (209062)

#	QTY.	PART #	DESCRIPTION
1	4	N20288	KIT, SPLIT FLANGE SFXK-16
2	4	N20818	ELBOW, 90DEG 16MJIC-16 CODE 62
3	1	N28903	ELBOW, 90DG TUBE 16MJIC-16FJIC
4	2	N19272	TEE, 16MJIC-16FJIC-16MJIC
5	2	207102	HOSE, 1 X 64 LONG -16FJIC B.E.
6	2	N30420	ADAPTER, -16MJIC -6MJIC
7	1	N29078	ELBOW, 90 DEG - 6MJIC - 6FJIC
8	2	207112	HOSE, 3/8 24 -6FJIC -8MORB
9	1	N29731	ADAPTER, 8MJC - 12MOR
10	1	N24827	ELBOW, 90 DEG - 8FJC - 8MJC
11	1	207114	HOSE, 1/2 24 -8FJIC -8FJIC
12	1	N19271	ADAPTER, 16MJIC - 16FJIC SWVL
13	1	N19270	ELBOW, 90 DEG - 16MJC - 16FJC
14	1	N37279	TEE, -6MJIC-6FJIC-6MJIC
15	1	209540	HOSE, 1/4 X 18 -4FP SW -6FJIC90
16	1	209543	ELBOW, 1/4" BLK 45 DEG STREET
17	1	N26333	ELBOW, 90 DEG - 8MJC - 12MOR
18	1	N38500	HOSE, 1/2 80 -8FJIC -8FJICW/AS-B-15 OAL
19	1	N11952	ELBOW, 90 DEG - 08MJIC - 08MOR
20	2	4195	BOLT, 3/8" X 1" GRADE 5
21	2	N16470	WASHER, 3/8 NORDLOCK
22	1	207129	MOUNT, FLUSH LOOP
23	2	4003	BOLT, 1/4" X 2-1/2" GRADE 5
24	1	200699	FLUSHING LOOP
25	2	4230	NUT, STANDARD 1/4"
26	2	N16468	WASHER, 1/4 NORDLOCK
27	1	200882	BULKHEAD, TEE RUN -8
28	1	N24835	ADAPTER, 8MOR - 8FJIC
29	1	N157054	VALVE, RELIEF 100PSI
30	1	N38520	ADAPTER, 90 -4MJIC -8MORB
31	1	N69021	HOSE, 1/4 X 14 -4FJIC -4FJIC
32	1	N38519	BULKHEAD, 45DEG -4MJIC-4MJIC
33	1	N90142	HOSE, 1/2 100 -8FJIC -8MORB
34	3	4250	NUT, STANDARD 1/2

Parts Identification

Hydraulics, Parker Motor Closed Loop Flushing (209062) (Cont'd)

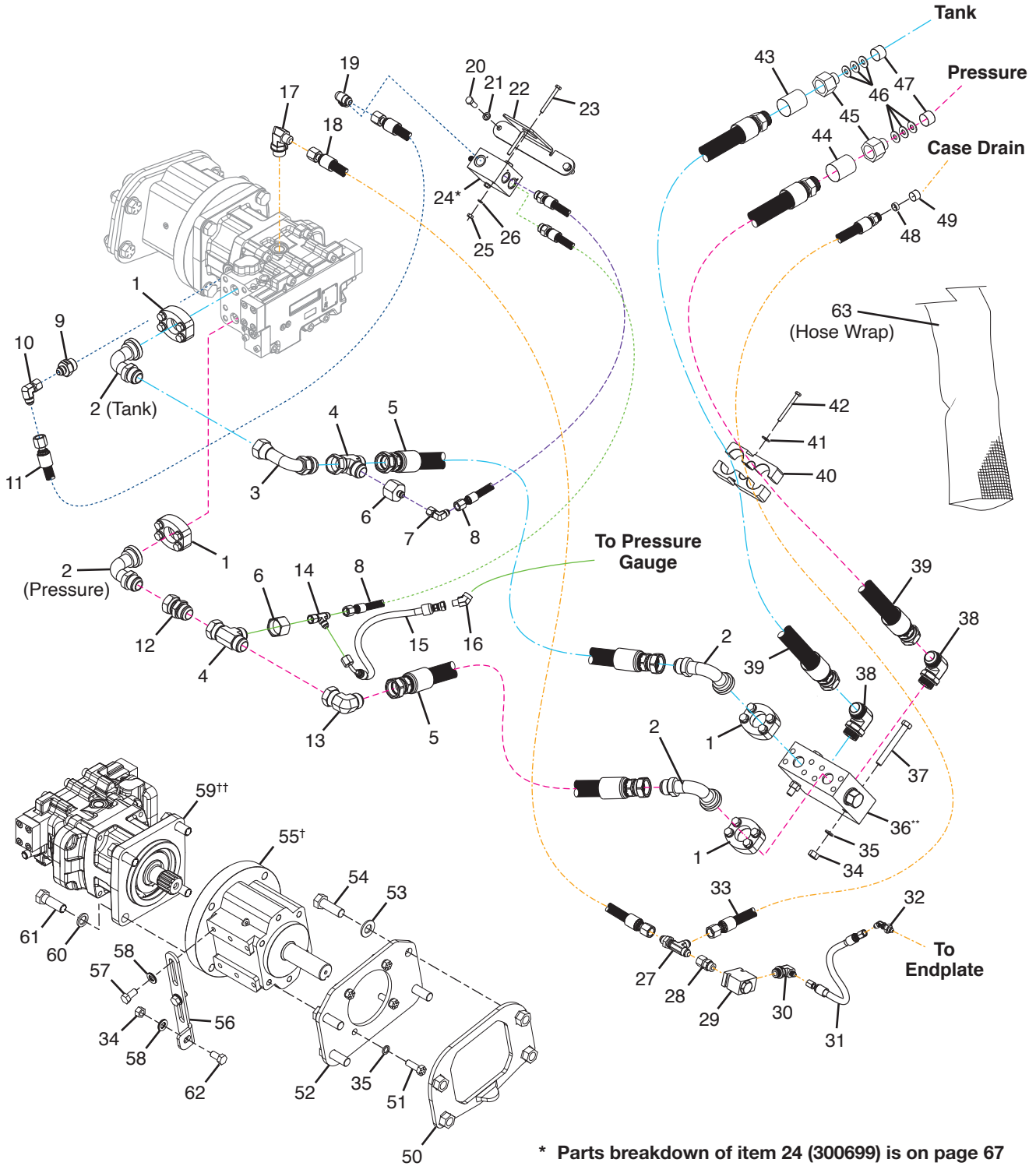

* Parts breakdown of item 24 (300699) is on page 67
 ** Parts breakdown of item 36 (200655) is on page 66.
 † Parts breakdown of item 55 (N51193) is on page 69.
 †† Parts breakdown of item 59 (207679) is on page 68.

Parts Identification

Hydraulics, Parker Motor Closed Loop Flushing (209062) (Cont'd)

#	QTY.	PART #	DESCRIPTION
35	6	N16472	WASHER, 1/2 NORDLOCK
36	1	200655	MANIFOLD, RELIEF 5000PSI,CHECK
37	2	4154	BOLT, 1/2" X 3-1/2" GR 5
38	2	N41121	ELBOW, 90 DEG -16MJIC-16MOR
39	2	207085	HOSE, 1 84 -16FJIC -16MORB
40	2	207128	CLAMP, HOSE HI-PRESSURE
41	1	3183	WASHER, FLAT 1/4"
42	1	N13811	BOLT, 1/4" X 2-3/4" GRADE 5
43	1	N24823	DECAL, RETURN
44	1	N24822	DECAL, PRESSURE
45	2	N28108	ADAPTER, - 12MOR - 16FOR
46	6	4064	WASHER, FLAT 3/8"
47	2	N15893	CAP, 3/4 ALUMINUM HOSE
48	1	N32002	PLUG, 3/8 SCH 40 X .25
49	1	N15895	CAP, 1/2 ALUMINUM HOSE
50	1	209068	PLATE, WELDMENT MOTOR
51	4	4466	BOLT, 1/2" X 1-1/2" GRADE 8
52	1	209072	PLATE, MOUNT MOTOR
53	4	N28567	WASHER, 3/4 NORDLOCK SP
54	4	4343	BOLT, 3/4" X 2-1/4" FN TH GR 8
55	1	N51193	OHLA, 900 W C TO D ADAPTER
56	1	N49792	PLATE, SUPPORT MOTOR ASSY
57	2	4011	BOLT, 1/2" X 1" GRADE 5
58	3	N37780	WASHER, NORD-LOCK 1/2" SP
59	1	207679	MOTOR, VARIABLE 90CC-110CC
60	4	N16474	WASHER, 3/4 NORDLOCK
61	4	208781	BOLT, 3/4IN X 2-1/4IN UNC GR 8
62	1	4012	BOLT, 1/2" X 1-1/4" GR 5
63	1	N90265	WRAP, HOSE 76

Parts Identification

Hydraulics, Muncie Fixed-Displacement Motor (209061)

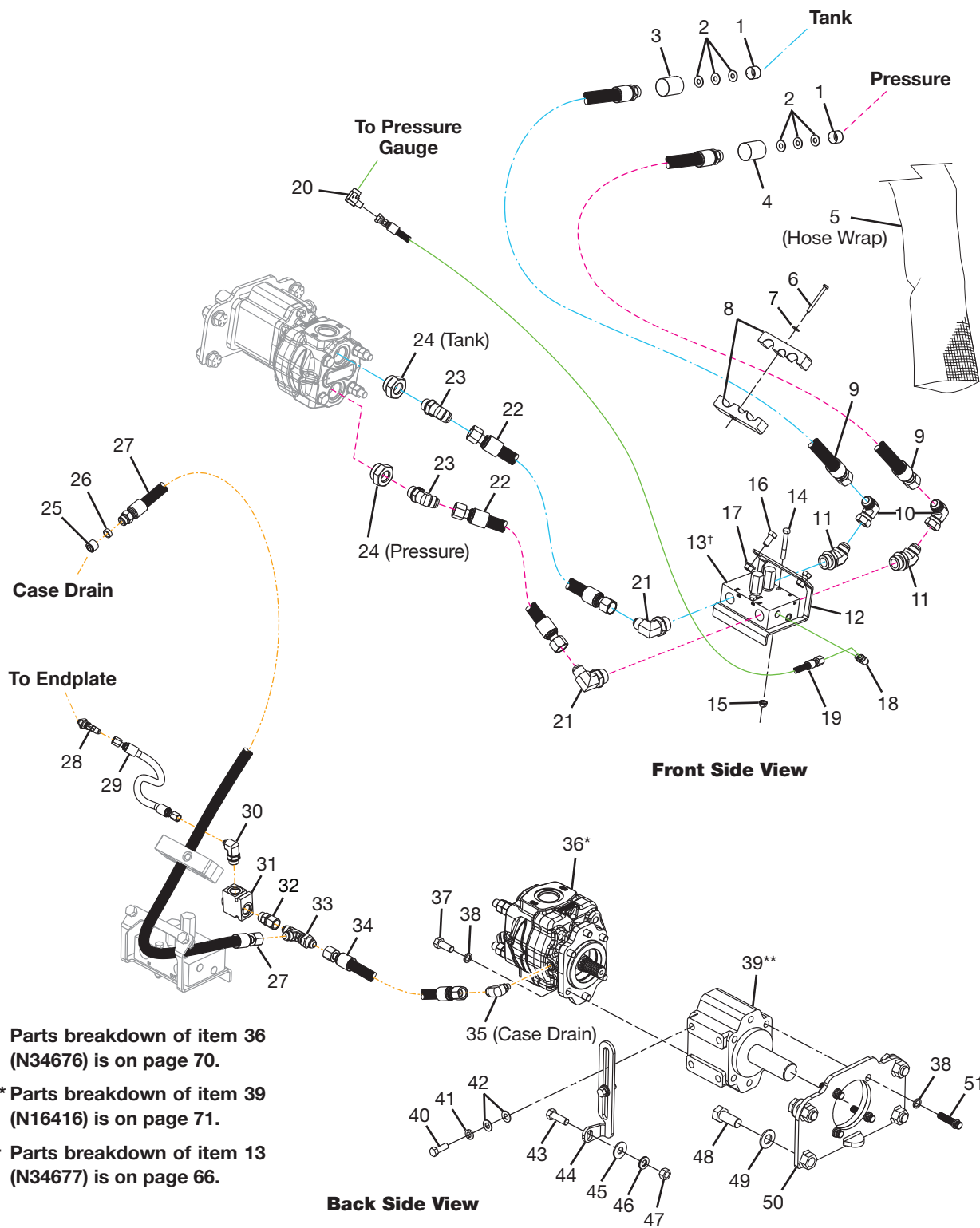

Parts Identification

Hydraulics, Muncie Fixed-Displacement Motor (209061)

#	QTY.	PART #	DESCRIPTION
1	2	N15893	CAP, 3/4 ALUMINUM HOSE
2	6	4064	WASHER, FLAT 3/8"
3	1	N24823	DECAL, RETURN
4	1	N24822	DECAL, PRESSURE
5	1	N90265	WRAP, HOSE 76
6	1	N13811	BOLT, 1/4" X 2-3/4" GRADE 5
7	1	3183	WASHER, FLAT 1/4"
8	2	N49110	CLAMP, HOSE
9	2	N49295	HOSE, 3/4" X 86" -12FJIC -12MOR
10	2	N21333	ELBOW, 90 DEG - 12MJIC -12FJIC
11	2	N16174	ELBOW, 45 DEG 12MJIC - 16MOR
12	1	209012	PLATE, MUNCIE VALVE BRACKET
13	1	N34677	BODY, VALVE CROSS PORT RELIEF
14	2	4538	BOLT, 3/8" X 2-3/4" GRADE 5
15	2	4979	NUT, LOCK 3/8" SER FLG
16	2	4011	BOLT, 1/2" X 1" GRADE 5
17	2	N29075	NUT, LOCK 1/2" SERRATED FLANGE
18	1	N28907	ELBOW, 90DEG -6MJIC -4MOR
19	1	209524	HOSE, 1/4 X 58 -4FPX -6FJIC
20	1	N16162	ELBOW, 1/4IN BLK 90 DEG STREET
21	2	N13876	ELBOW, 90 DEG - 16MOR - 12MJIC
22	2	N49293	HOSE, 3/4" X 61"-12FJIC-12FJIC
23	2	N25883	ELBOW, 45 DEG - 12MJC - 12MOR
24	2	N31225	ADAPTER, 20MOR - 12FOR
25	1	N15895	CAP, 1/2 ALUMINUM HOSE
26	1	N32002	PLUG, 3/8 SCH 40 X .25
27	1	209014	HOSE, 1/2 X 102 -8FJIC -8MOR
28	1	N38519	BULKHEAD, 45DEG -4MJIC-4MJIC
29	1	N69021	HOSE, 1/4 X 14 -4FJIC -4FJIC
30	1	N38520	ADAPTER, 90 -4MJIC -8MORB
31	1	N157054	VALVE, RELIEF 100PSI
32	1	N24835	ADAPTER, 8MOR - 8FJIC
33	1	200882	BULKHEAD, TEE RUN -8
34	1	N38500	HOSE, 1/2 X 80 -8FJIC -8FJIC

Parts Identification

Hydraulics, Muncie Fixed-Displacement Motor (209061) (Cont'd)

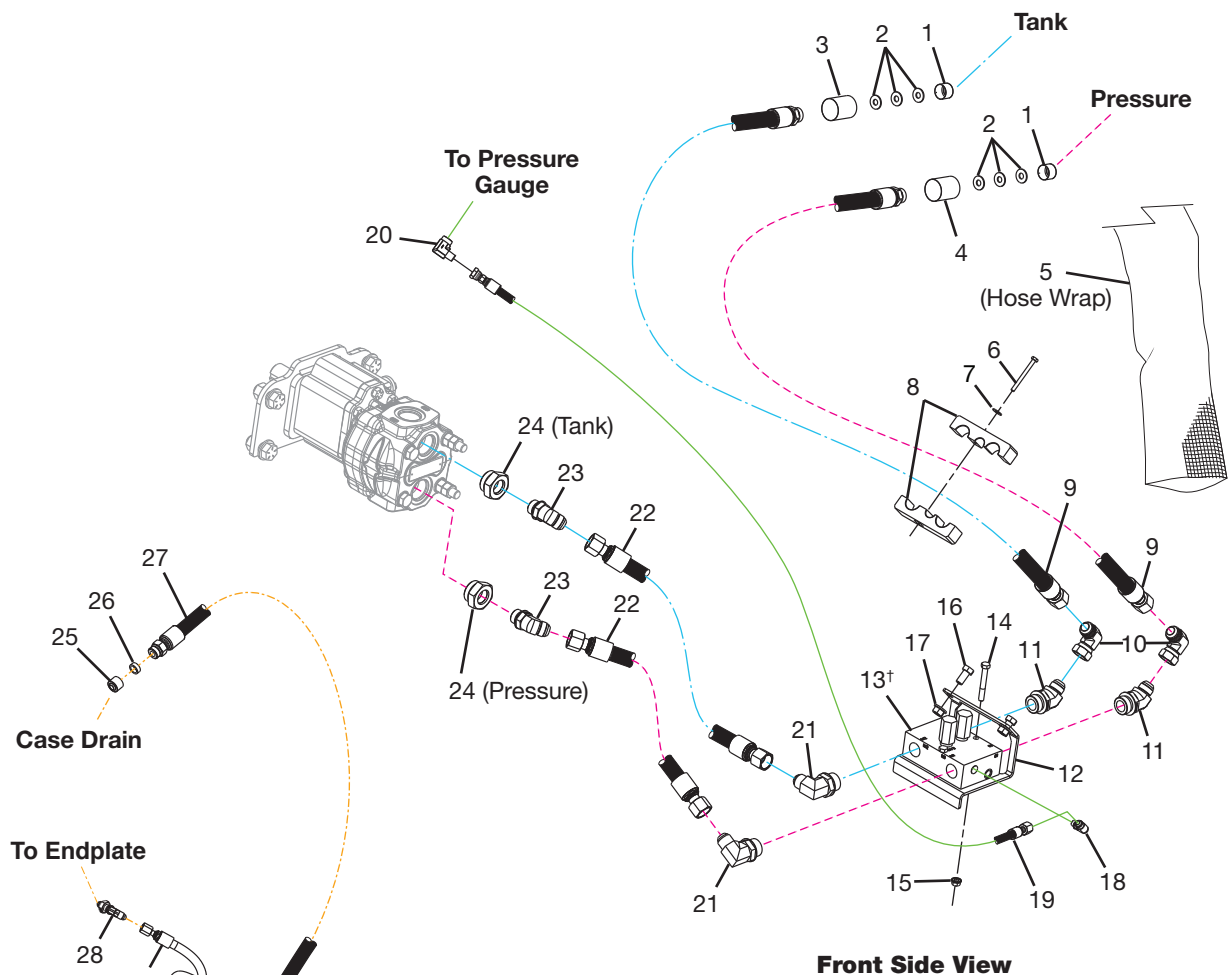

Front Side View

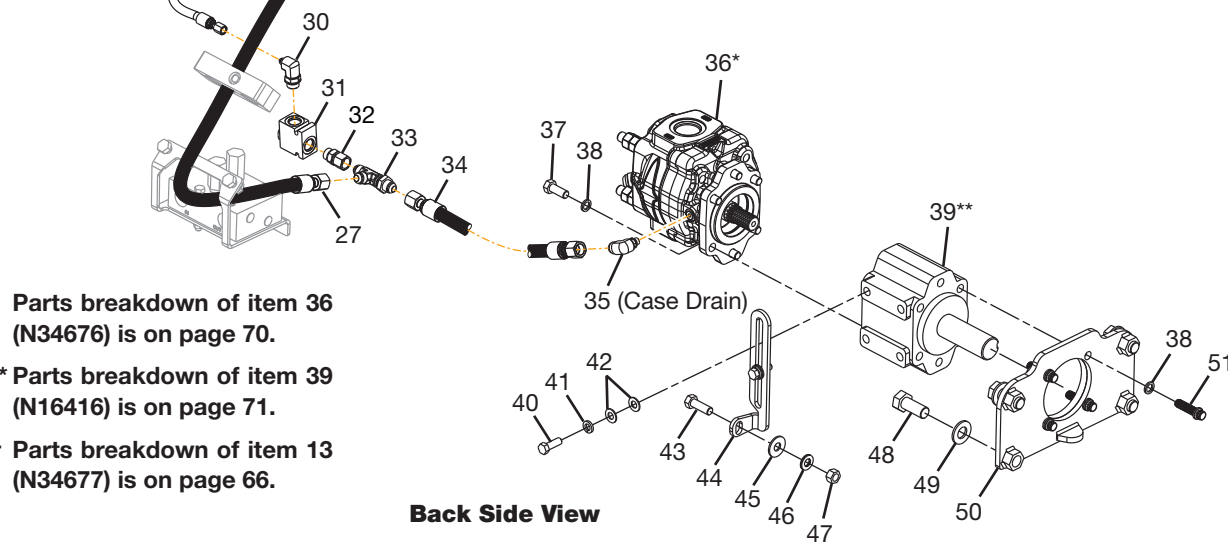

Back Side View

* Parts breakdown of item 36 (N34676) is on page 70.
 ** Parts breakdown of item 39 (N16416) is on page 71.
 † Parts breakdown of item 13 (N34677) is on page 66.

Parts Identification

Hydraulics, Muncie Fixed-Displacement Motor (209061) (Cont'd)

#	QTY.	PART #	DESCRIPTION
35	1	N34763	ELBOW, 90 -8MJIC -4MORB
36	1	N34676	MOTOR, MUNCIE 62.9CC
37	6	4466	BOLT, 1/2" X 1-1/2" GR 8
38	10	N16472	WASHER, 1/2 NORDLOCK
39	1	N16416	ADAPTER, OVERHUNG LOAD MOTOR #2
40	2	4009	BOLT, 7/16" X 1-1/4" GRADE 5
41	2	4367	WASHER, 7/16" LOCK
42	4	4301	WASHER, 7/16" FLAT
43	1	4466	BOLT, 1/2" X 1-1/2" GRADE 8
44	1	N49108	G4 MUNCIE MOTOR BRACKET
45	1	4486	WASHER, 1/2" FLAT
46	1	N37780	WASHER, NORD-LOCK 1/2" SP
47	1	4250	NUT, STANDARD 1/2
48	4	N16753	BOLT, 3/4" X 1-3/4" FN THD GR 8
49	4	N28567	WASHER, 3/4 NORDLOCK SP
50	1	209070	MOUNT, BA RR MUNCIE MOTOR
51	4	N31536	BOLT, 1/2 X 1-3/4 12 PT GRD8

Parts Identification

Valve, Cross Port Relief (N34677)

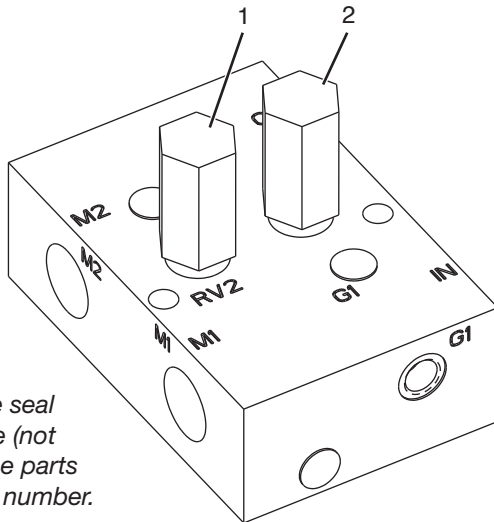

NOTE: Relief valve seal kit available (not shown). See parts list for part number.

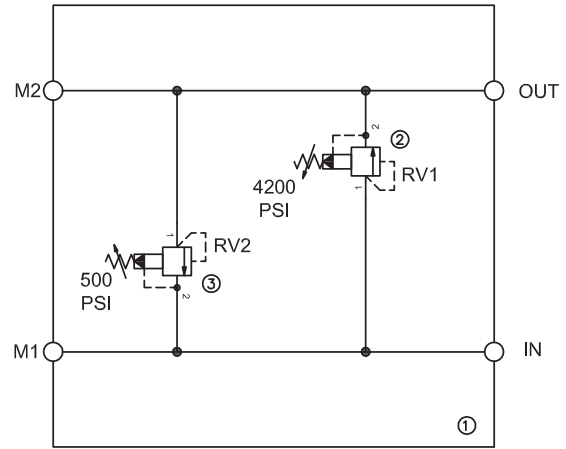

#	QTY.	PART #	DESCRIPTION
1	1	N142316	VALVE, RELIEF 500 PSI (INCLUDED WITH N34677)
2	1	N142314	VALVE, RELIEF 4200 PSI (INCLUDED WITH N34677)
3	1	N142318	KIT, VITON VALVE SEAL (NOT SHOWN)

Manifold, Relief 5000 PSI, Check (200655)

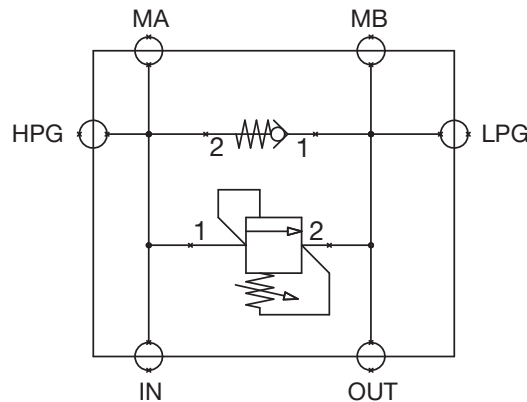
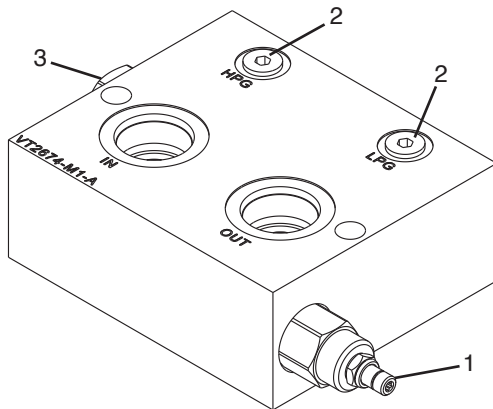

#	QTY.	PART #	DESCRIPTION
1	1	N28099	VALVE, RELIEF 5000PSI
2	2	N14118	PLUG, 6MOR HEX
3	1	200695	VALVE, CHECK

Manifold, Closed Loop Flushing (200699)

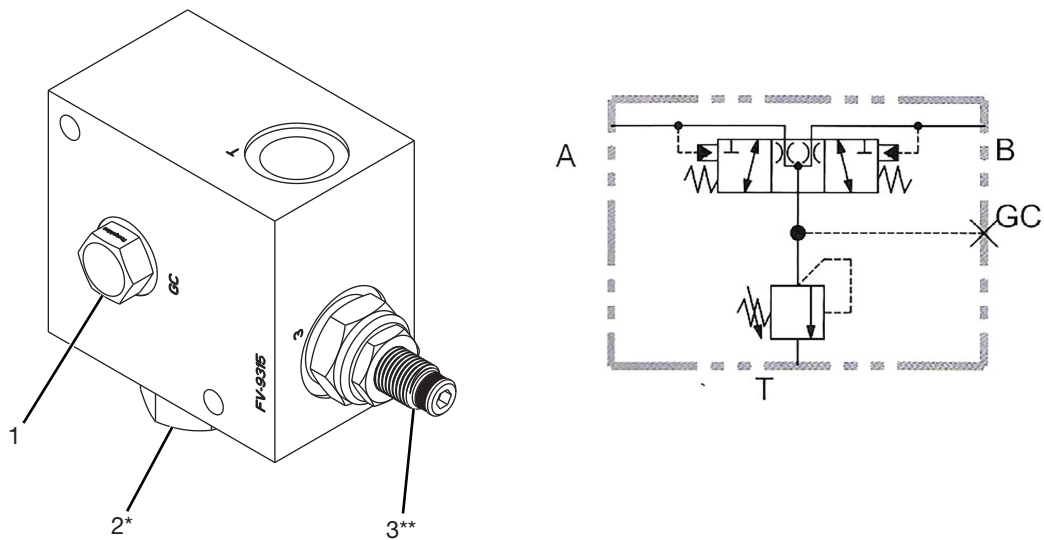

* Use item 4, part number 207139, for seal kit for item 2.

** Use item 5, part number 207140, for seal kit for item 3.

#	QTY.	PART #	DESCRIPTION
1	1	N28286	PLUG, 6MOR HEX
2	1	207115*	CARTRIDGE, SHUTTLE HOT OIL
3	1	207116**	VALVE, RELIEF
4	1	207139	KIT, SEAL (Not Shown) - for cartridge 207115
5	1	207140	KIT, SEAL (Not Shown) - for relief valve 207116

Parts Identification

Hydraulic Motor, Variable 90cc to 110cc (207679)

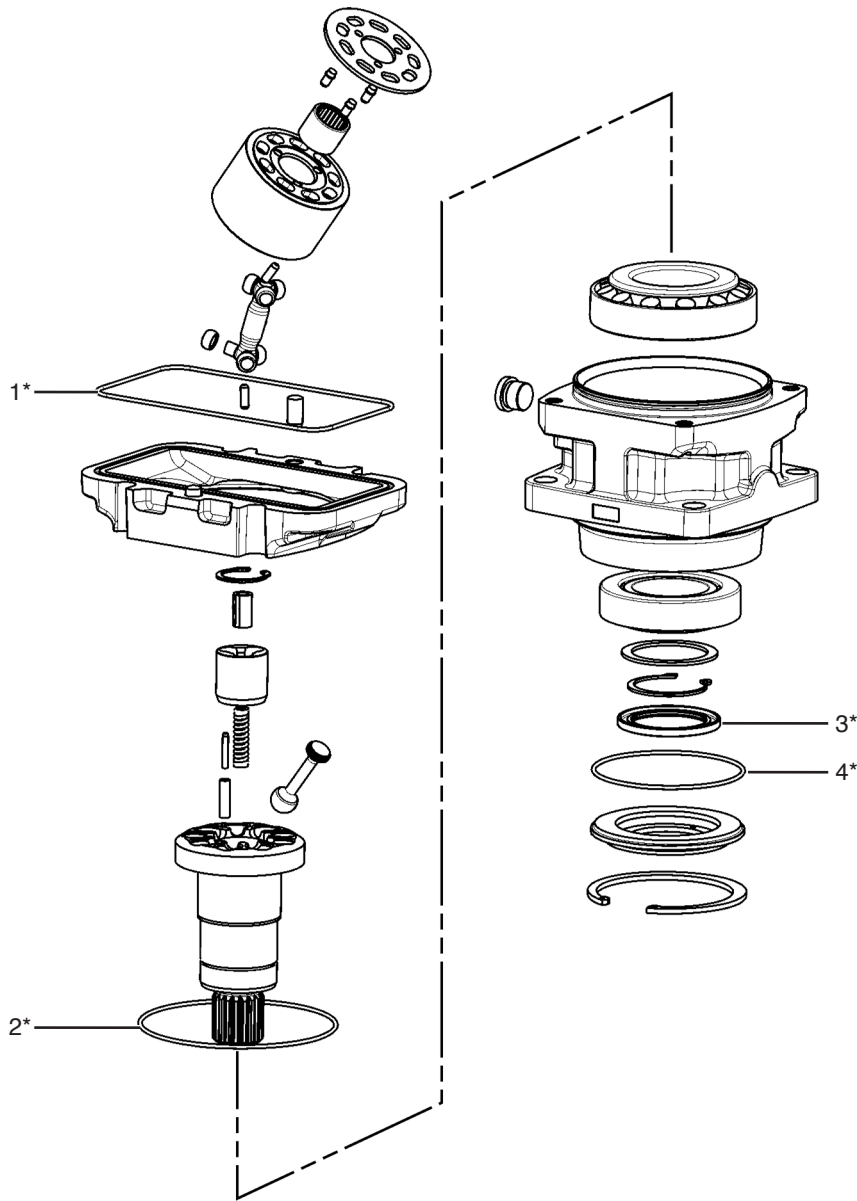

NOTE: Other items included in kit should only be replaced by authorized service center.

#	QTY.	PART #	DESCRIPTION
*	1	N28376	SEAL KIT (Includes Items 1, 2, 3, and 4)
1	1	-	O-RING 194.1 X 3 V80 / 220 X 3 V80
2	1	-	O-RING 144.5 X 3 V70 / 168 x 3 V70
3	1	-	SHAFT SEAL 60 X 80 X 6
4	1	-	O-RING 114.5 X 3 V80

Overhung Load Adapter (N51193)

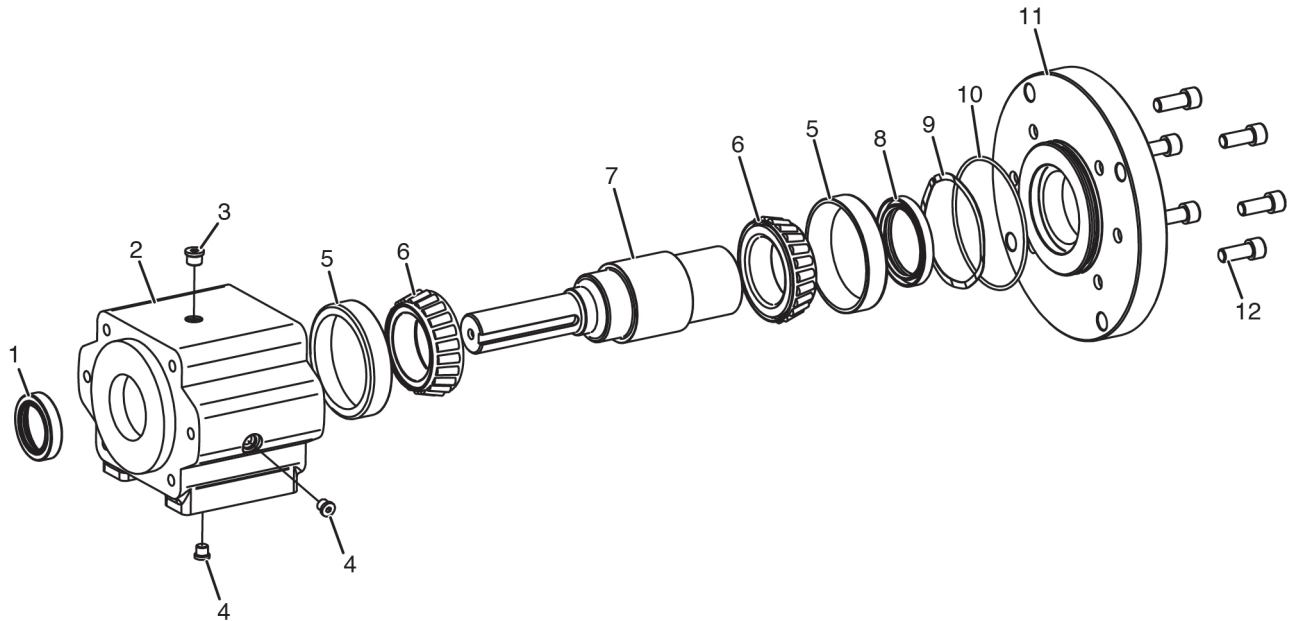

NOTE: Hydraulic oil capacity is approximately 6 oz.

#	QTY.	PART #	DESCRIPTION
1	1	200020	FRONT SEAL, WITH TOOL
2	1	N/A	HOUSING 900
3	1	N14118	PLUG #6 BOSS
4	2	N16578	PLUG #4 BOSS
5	2	N34130	BEARING CUP
6	2	N34131	BEARING CONE
7	1	N/A	SHAFT 915-13S
8	1	N38542	REAR SEAL
9	2	N38541	WAVE SPRING SSB-0433
10	1	N38543	O-RING 2-248
11	1	N/A	REAR ADAPTER PLATE
12	6	N28529	SCREW SHCS 0.500-13 X 1.25 LG

Parts Identification

Hydraulic Motor, 62.9cc (N34676)

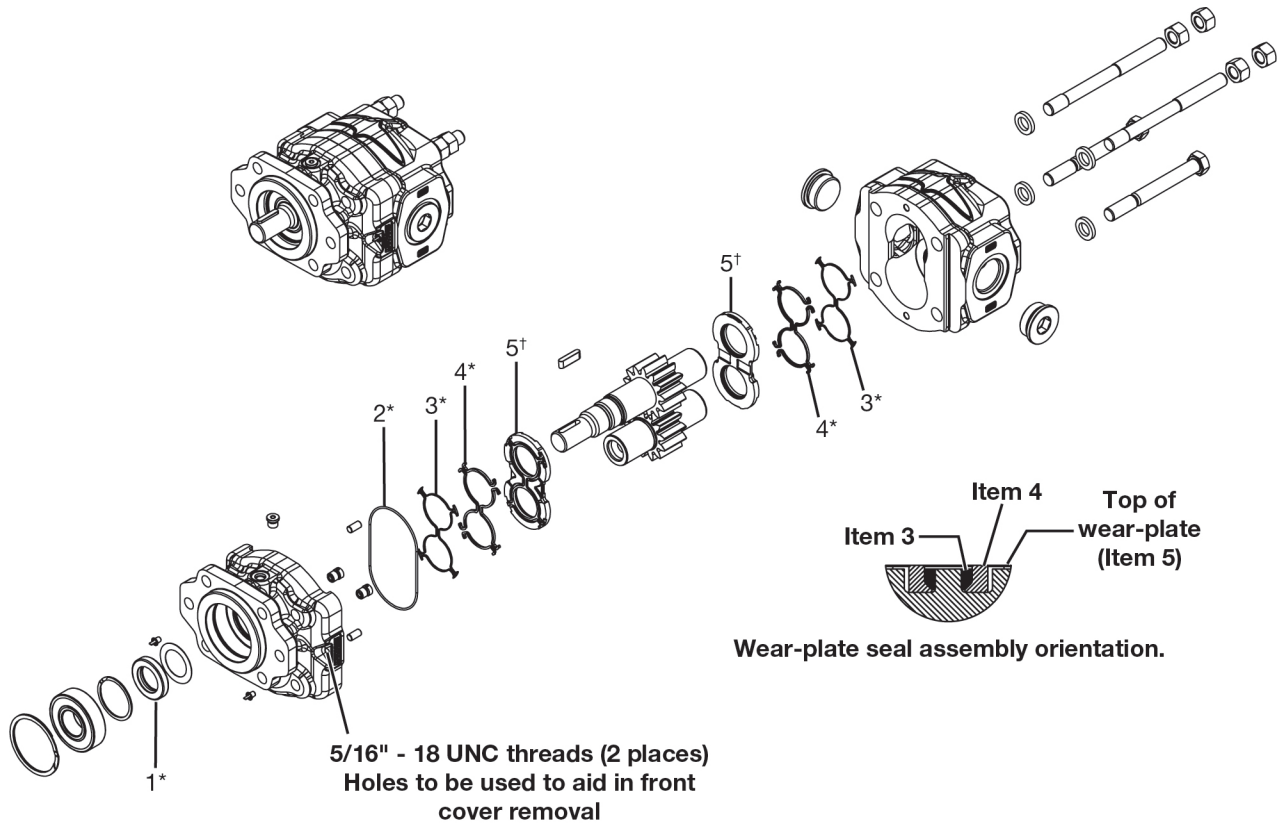

#	QTY.	PART #	DESCRIPTION
*	1	N144330	SEAL KIT (Includes Items 1, 2, 3, 4)
* †	1	N144332	REBUILD KIT (Includes Items 1, 2, 3, 4, 5)
1	1	N34699	SHAFT SEAL HIGH PRESSURE
2	1	-	BODY SEAL
3	2	-	BACKUP SEAL
4	4	-	BALANCE SEAL
5	2	-	WEAR PLATE

Overhung Load Adapter (N16416)

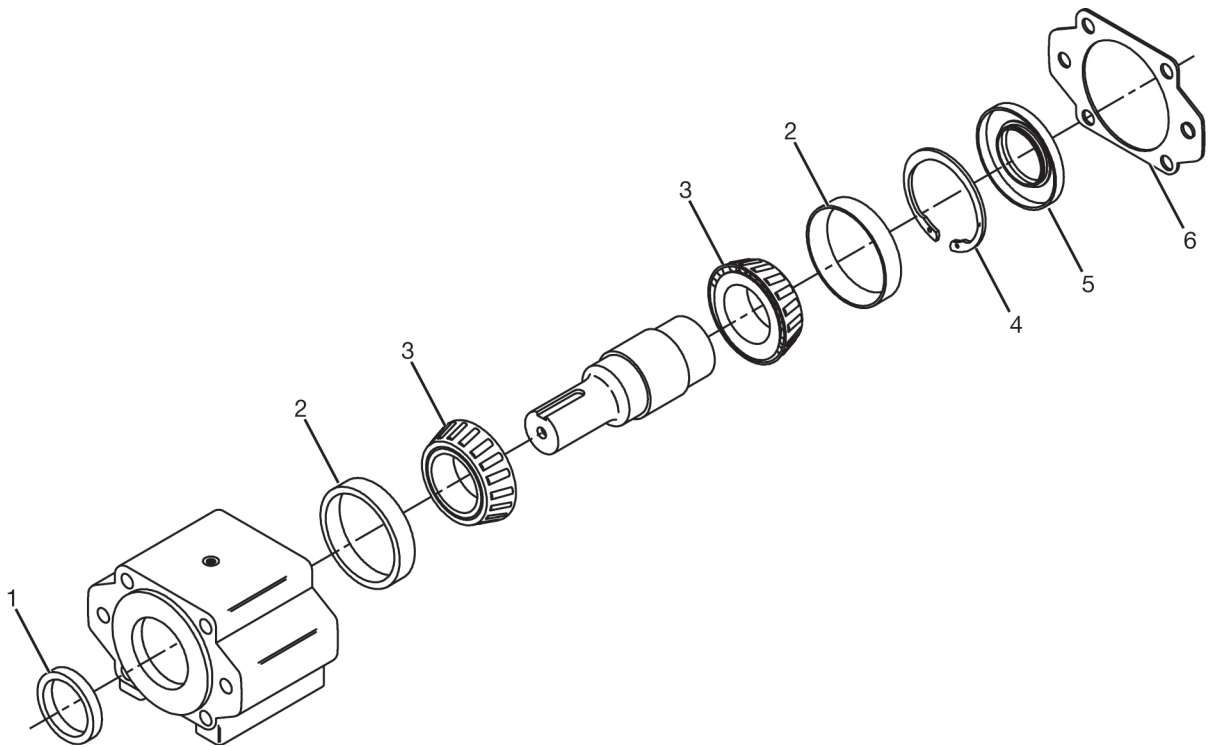

NOTE: Hydraulic oil capacity is approximately 4 oz.

#	QTY.	PART #	DESCRIPTION
1	1	N14151	SEAL, FRONT (1.50" I.D. X 2.13" O.D. X .312" THK)
2	2	N14152	CUP, BEARING
3	2	N14153	CONE, BEARING
4	1	N14156	RING, RETAINING
5	1	N14157	SEAL, REAR (55MM X 90MM X 10MM)
6	1	N14158	GASKET

Parts Identification

Rotor Assembly, 206983 - 61" Rotor With Carbide Cutter; **206981** - 61" Rotor With Quadco Cutter; **206982** - 61" Rotor With Quadco Hard Surface Cutter; **206986** - 71" Rotor With Carbide Cutter; **206984** - 71" Rotor With Quadco Cutter; **206985** - 71" Rotor With Quadco Hard Surface Cutter

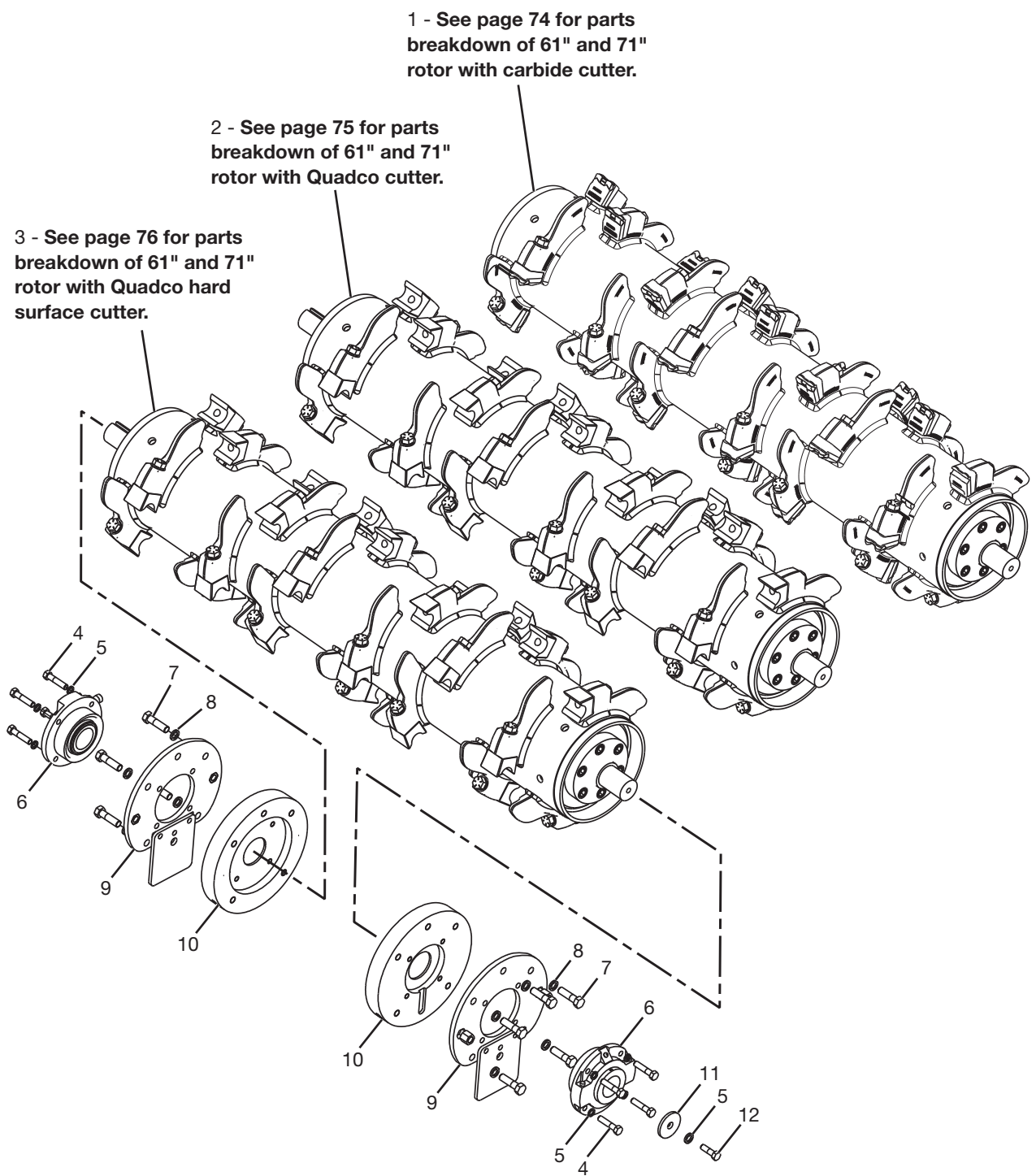

Parts Identification

Rotor Assembly, 206983 - 61" Rotor With Carbide Cutter; **206981** - 61" Rotor With Quadco Cutter; **206982** - 61" Rotor With Quadco Hard Surface Cutter; **206986** - 71" Rotor With Carbide Cutter; **206984** - 71" Rotor With Quadco Cutter; **206985** - 71" Rotor With Quadco Hard Surface Cutter

#	QTY.	PART #	DESCRIPTION
1	1	202529*	ROTOR, 61" BS BETEK W/CARBIDE BOLT-IN BULKHEAD
	1	202536*	71"
2	1	202524**	ROTOR, 61" BS BETEK W/QUADCO BOLT-IN BULKHEAD
	1	202531**	71"
3	1	202527***	ROTOR, 61" BS BETEK W/QUADCO HARD SURFACE TEETH BOLT-IN BULKHEAD
	1	202534***	71"
4	8	N20043	BOLT, 1/2" X 2-1/4" FN TD GR 8
5	9	N16472	WASHER, 1/2 NORDLOCK
6	2	214404	BEARING, 2-3/16" PILOT ROLLER
7	10	N13747	BOLT, 5/8" X 1-3/4" FN TH GR 8
8	10	N16473	WASHER, 5/8 NORDLOCK
9	2	206987	MOUNT, BEARING WELDMENT
10	2	N41564	ANTIWRAP, 2 PIECE CARBIDE 11"
11	1	209547	PLATE, BEARING RET. 2.625 OD
12	1	4435	BOLT, 1/2" X 1-1/2" FN TD GRADE 8

* See page 74 for parts breakdown of 61" and 71" rotor with carbide cutter.

** See page 75 for parts breakdown of 61" and 71" rotor with Quadco cutter.

*** See page 76 for parts breakdown of 61" and 71" rotor with Quadco hard surface cutter.

Parts Identification

Rotor, Bolt-in Bulkhead with Double Carbide Teeth - 61" (202529), 71" (202536)

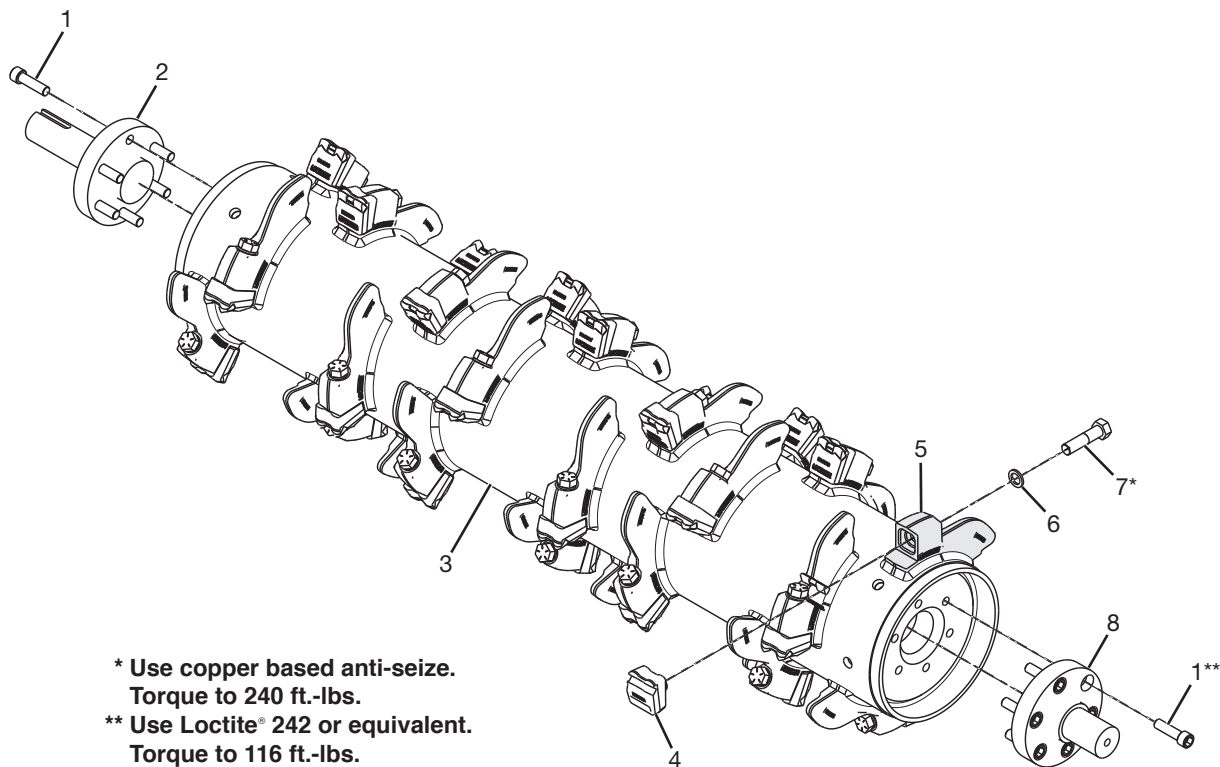

* Use copper based anti-seize.
Torque to 240 ft.-lbs.
** Use Loctite® 242 or equivalent.
Torque to 116 ft.-lbs.

#	QTY.	PART #	DESCRIPTION
1	12	N38265	BOLT, SHCS 5/8 X 2-1/4 FN GR 8
2	1	202305	WASHER, DRIVE 2-3/16" BOLT-ON
3	1	202525	ROTOR, 61" BS BETEK W/O CUTTERS
	1	202532	ROTOR, 71" BS BETEK W/O CUTTERS
4	30	N49090	TOOTH, BATTLE AX CARBIDE (61")
	36	N49090	TOOTH, BATTLE AX CARBIDE (71")
5	30	203315	HOLDER, BATTLEAX
	36	203315	HOLDER, BATTLEAX
6	30	N16474	WASHER, 3/4 NORDLOCK (61")
	36	N16474	WASHER, 3/4 NORDLOCK (71")
7	30	N21308	BOLT, 3/4" X 3" FN THRD GR 8 (61")
	36	N21308	BOLT, 3/4" X 3" FN THRD GR 8 (71")
8	1	202306	WASHER, DRIVEN 2-3/16" BOLT-ON

Parts Identification

Rotor, Bolt-in Bulkhead with Quadco Teeth - 61" (202524), 71" (202531)

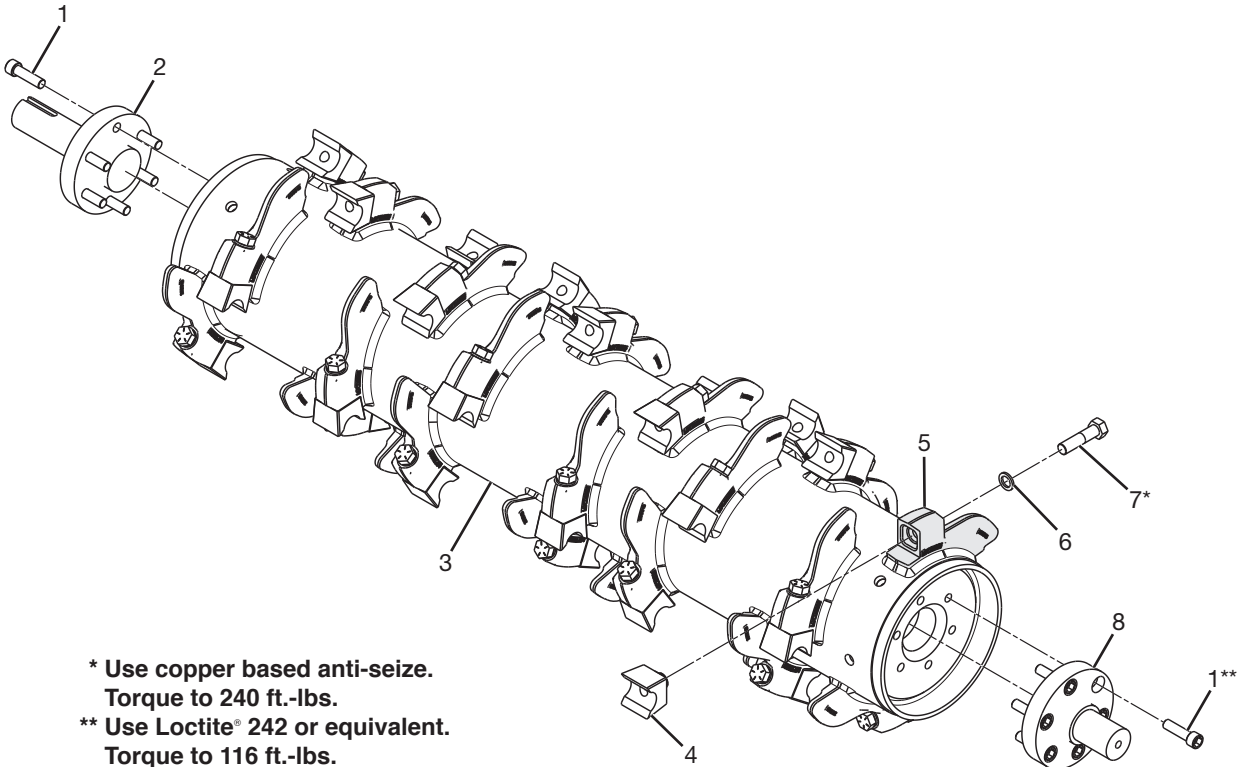

- * Use copper based anti-seize.
Torque to 240 ft.-lbs.
- ** Use Loctite® 242 or equivalent.
Torque to 116 ft.-lbs.

#	QTY.	PART #	DESCRIPTION
1	12	N38265	BOLT, SHCS 5/8 X 2-1/4 FN GR 8
2	1	202305	WASHER, DRIVE 2-3/16" BOLT-ON
3	1	202525	ROTOR, 61" BS BETEK W/O CUTTERS
	1	202532	ROTOR, 71" BS BETEK W/O CUTTERS
4	30	N49366	TOOTH, BA QUADCO PLANER (61")
	36	N49366	TOOTH, BA QUADCO PLANER (71")
5	30	203315	HOLDER, BATTLEAX
	36	203315	HOLDER, BATTLEAX
6	30	N16474	WASHER, 3/4 NORDLOCK (61")
	36	N16474	WASHER, 3/4 NORDLOCK (71")
7	30	N21308	BOLT, 3/4" X 3" FN THRD GR 8 (61")
	36	N21308	BOLT, 3/4" X 3" FN THRD GR 8 (71")
8	1	202306	WASHER, DRIVEN 2-3/16" BOLT-ON

Parts Identification

Rotor, Bolt-in Bulkhead with Quadco Hard Surface Teeth - 61" (202527), 71" (202534)

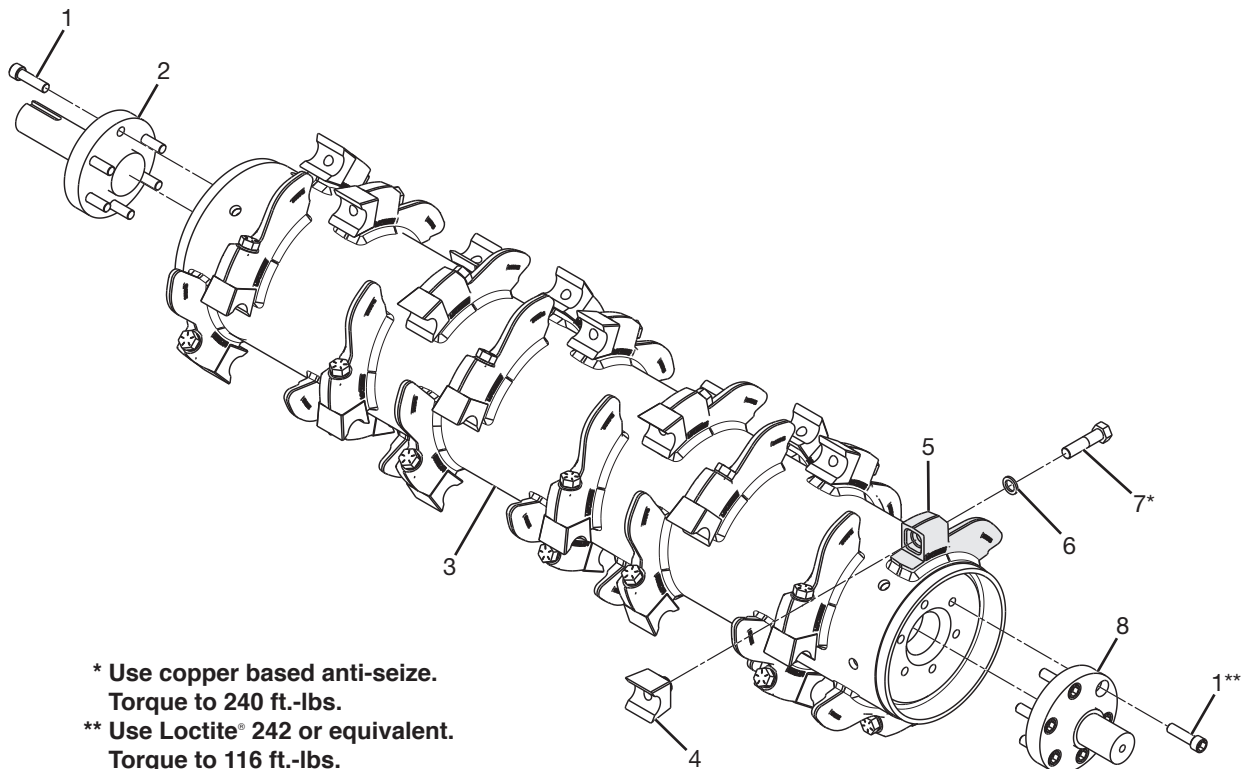

* Use copper based anti-seize.
Torque to 240 ft.-lbs.
** Use Loctite® 242 or equivalent.
Torque to 116 ft.-lbs.

#	QTY.	PART #	DESCRIPTION
1	12	N38265	BOLT, SHCS 5/8 X 2-1/4 FN GR 8
2	1	202305	WASHER, DRIVE 2-3/16" BOLT-ON
3	1	202525	ROTOR, 61" BS BETEK W/O CUTTERS
	1	202532	ROTOR, 71" BS BETEK W/O CUTTERS
4	30	203014	BATTLE AX TOOTH, QUADCO PLANER H (61")
	36	203014	BATTLE AX TOOTH, QUADCO PLANER H (71")
5	30	203315	HOLDER, BATTLEAX
	36	203315	HOLDER, BATTLEAX
6	30	N16474	WASHER, 3/4 NORDLOCK (61")
	36	N16474	WASHER, 3/4 NORDLOCK (71")
7	30	N21308	BOLT, 3/4" X 3" FN THRD GR 8 (61")
	36	N21308	BOLT, 3/4" X 3" FN THRD GR 8 (71")
8	1	202306	WASHER, DRIVEN 2-3/16" BOLT-ON

Lubrication

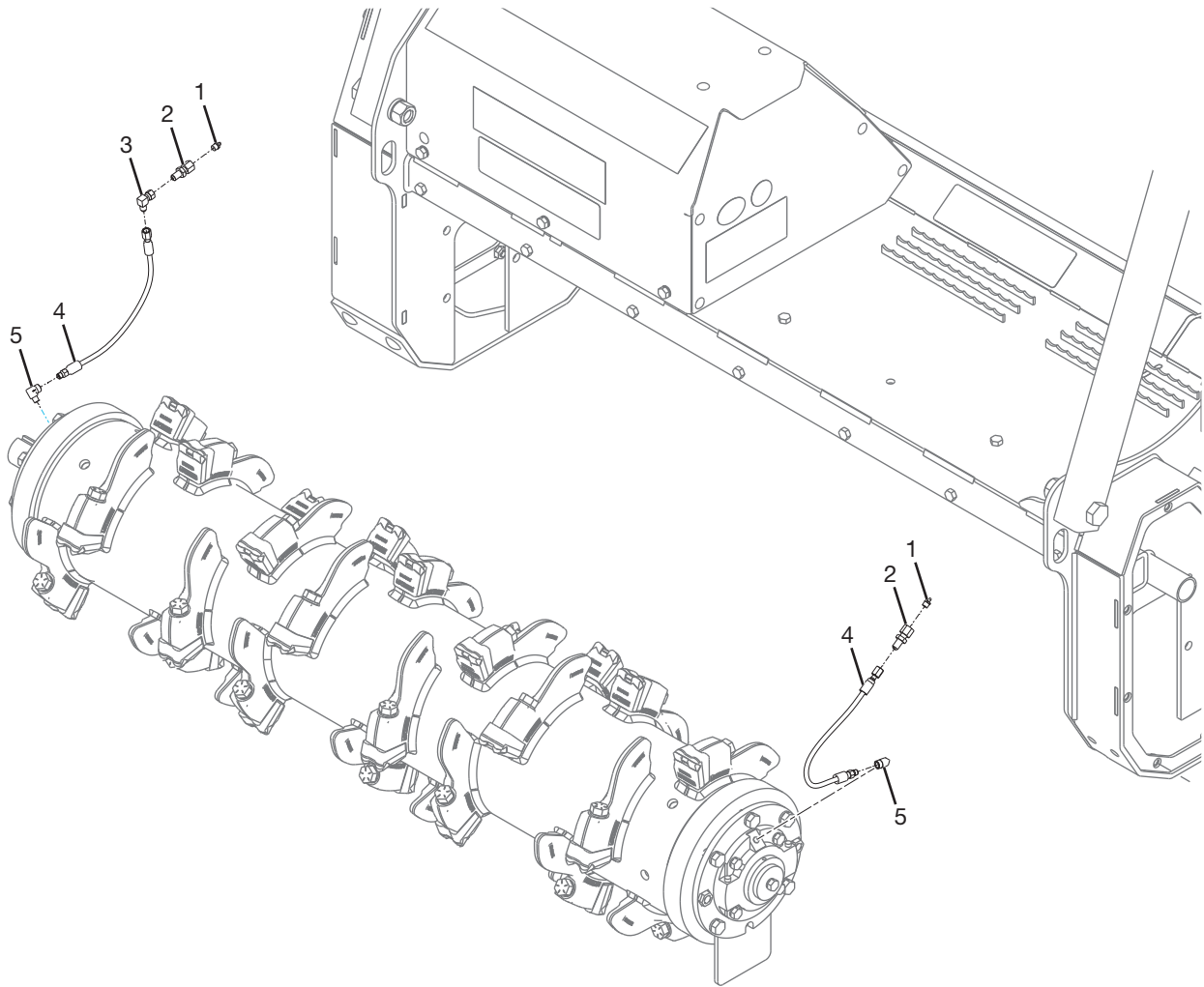

#	QTY.	PART #	DESCRIPTION
1	2	N17007	GREASEZERK, 1/8" NPT
2	2	4304-10	BULKHEAD, FITTING-GREASE HOSE
3	1	N25125	ELBOW, 90 DEG - 4FJIC - 4MJIC
4	2	4304	HOSE, GREASE 1/8" X 15"
5	2	4472	ELBOW, 1/8" 90 DEG.STREET

Parts Identification

Machine Decals and Signs

NOTE: All safety related decals are also shown in the Safety Instructions Section along with their location on the machine. See "Safety Decal Locations" on page 9.

Check and replace any worn, torn, hard to read or missing decals on your machine.

Part No. N17013

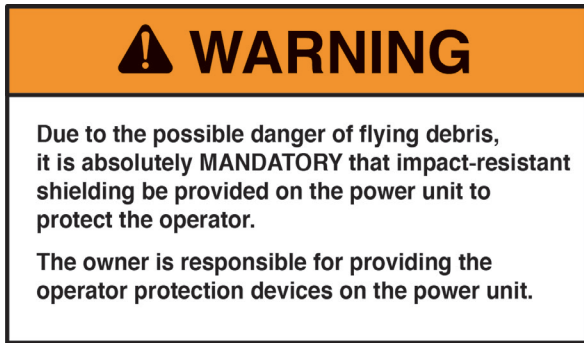

Part No. N20661

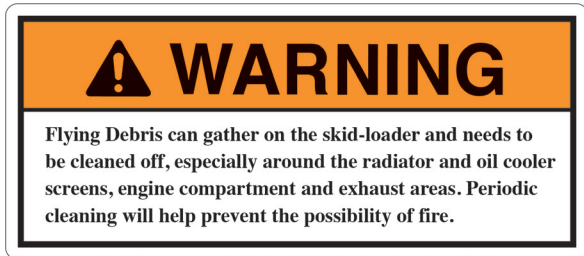

Part No. N17014

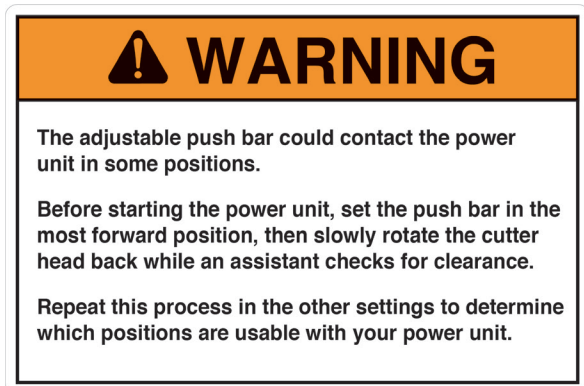

Part No. N28385

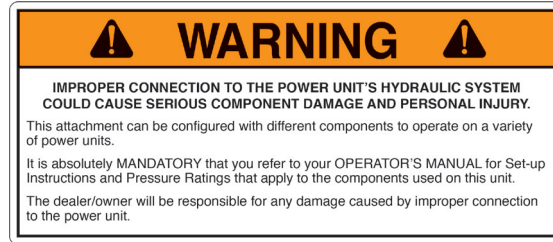

Part No. N68716

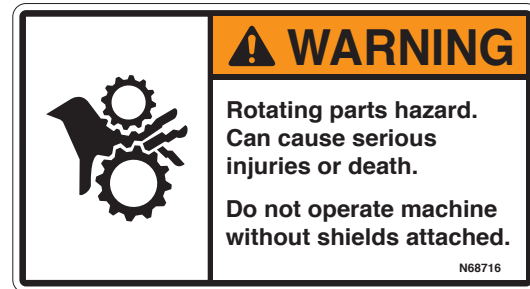

Part No. N28386



Part No. 4334



Part No. 203264



Machine Decals and Signs (Cont'd)

Part No. N68724



Part No. N29769



Part No. 4256

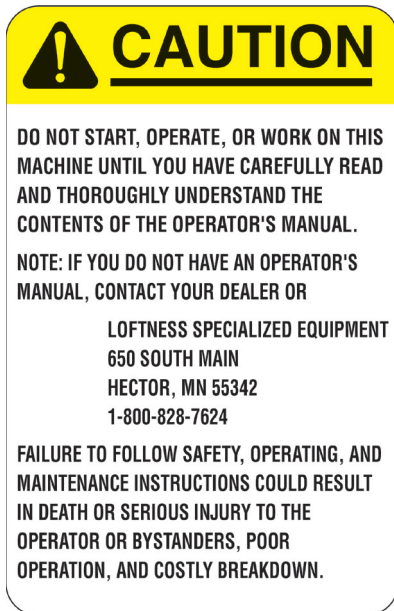

Part No. N24823



Part No. N24822

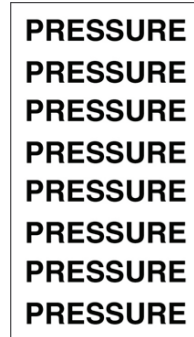

Part No. N28010

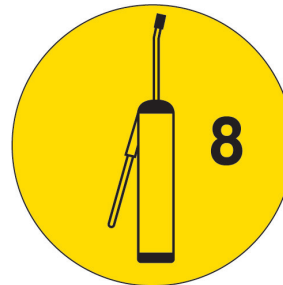

Part No. 200491



Part No. N13721



Parts Identification

Machine Decals and Signs (Cont'd)

Part No. N13517



Part No. 4138



Part No. N26973



Part No. N28576



Part No. 209499



Part No. 212605



Kit, Right Hand Hose Conversion - 4,000 PSI (209065)

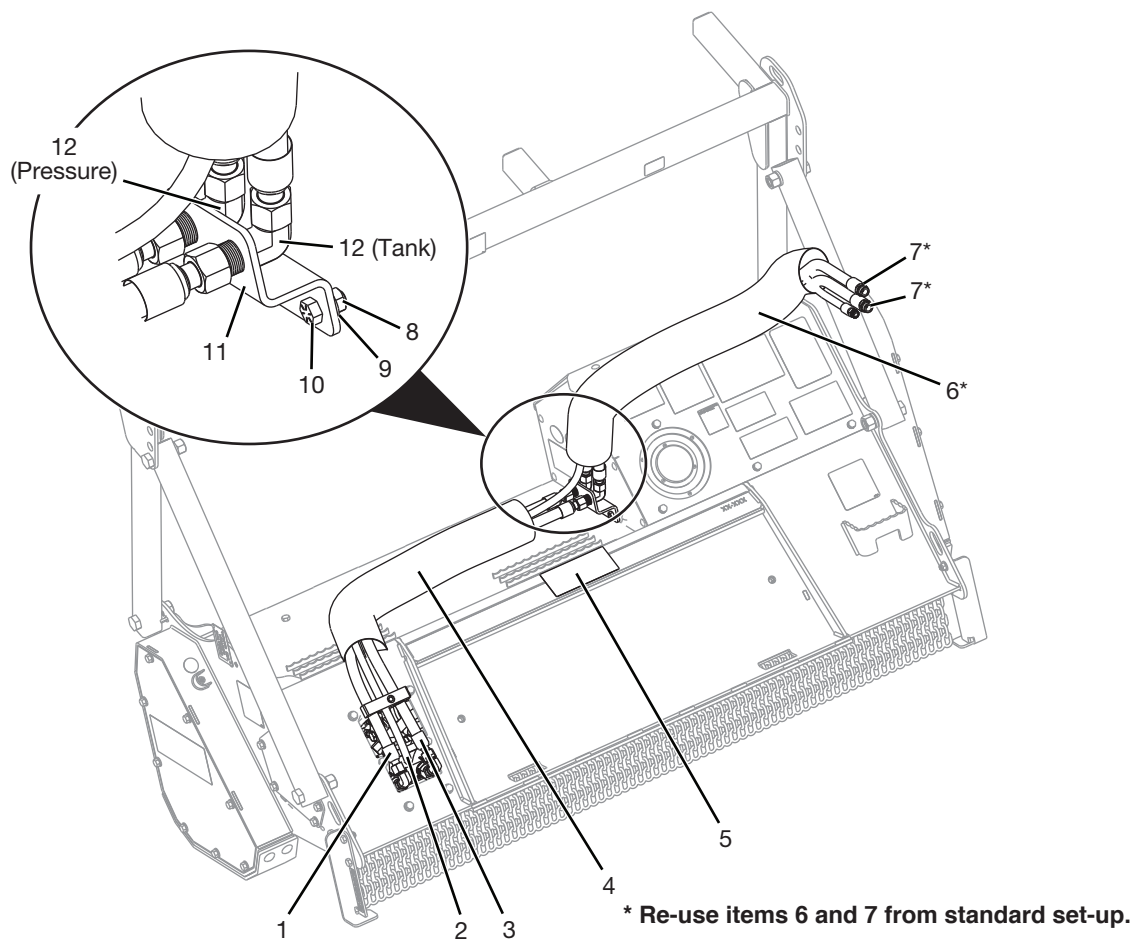

#	QTY.	PART #	DESCRIPTION
1	1	207809	HOSE, 3/4 52 -12FJIC -12FJIC
2	1	N158159	HOSE, 1/2 160 -8FJIC -8MORB
3	1	207810	HOSE, 3/4 49 -12FJIC -12FJIC
4	1	N159526	WRAP, HOSE 45
5	1	N28385	DECAL, CASE DRAIN WARNING
6	1	N90265	WRAP, HOSE 76
7	2	N49295	HOSE, 3/4 86 -12FJIC -12MORB
8	2	4054	NUT, LOCK 1/2" TOP
9	2	4068	WASHER, 1/2" SAE FLAT
10	2	4465	BOLT, 1/2" X 1" GRADE 8
11	1	207813	PLATE, BULKHEAD MOUNT 3/4
12	2	N34029	ADAPTER, 90 BULKHEAD -12MJIC

Options

Kit, Right Hand Hose Conversion - 6,000 PSI (209064)

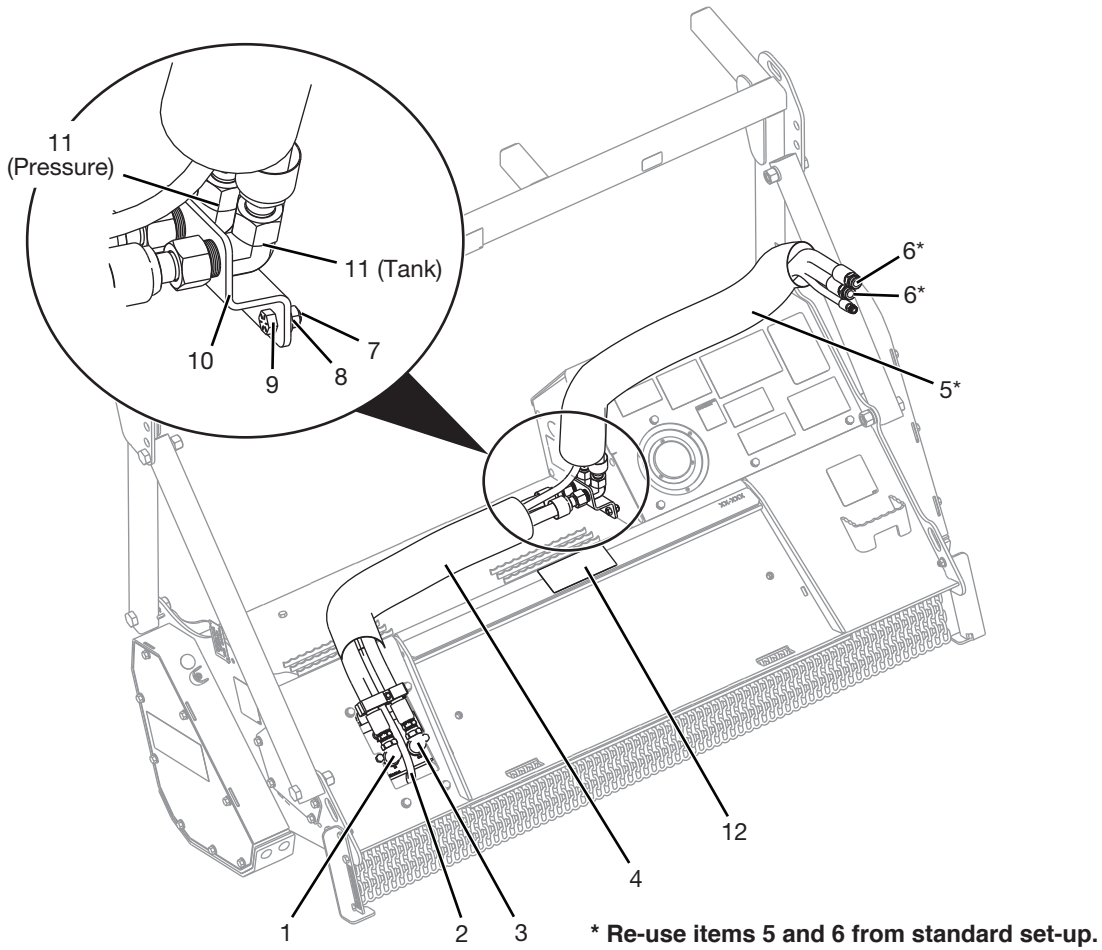

#	QTY.	PART #	DESCRIPTION
1	1	207086	HOSE, 1 52 -16FJIC -16FJIC
2	1	N158159	HOSE, 1/2 160 -8FJIC -8MORB
3	1	207087	HOSE, 1 49 -16FJIC -16FJIC
4	1	N159526	WRAP, HOSE 45
5	1	N90265	WRAP, HOSE 76
6	2	207085	HOSE, 1 84 -16FJIC -16MORB
7	2	4054	NUT, LOCK 1/2" TOP
8	2	4068	WASHER, 1/2" SAE FLAT
9	2	4465	BOLT, 1/2" X 1" GRADE 8
10	1	N158059	PLATE, BULKHEAD MOUNT
11	2	N157919	ADAPTER, 90 BULKHEAD -16MJIC
12	1	N28385	DECAL, CASE DRAIN WARNING

Liner, Bolt-in - 61" (209043), 71" (209044)

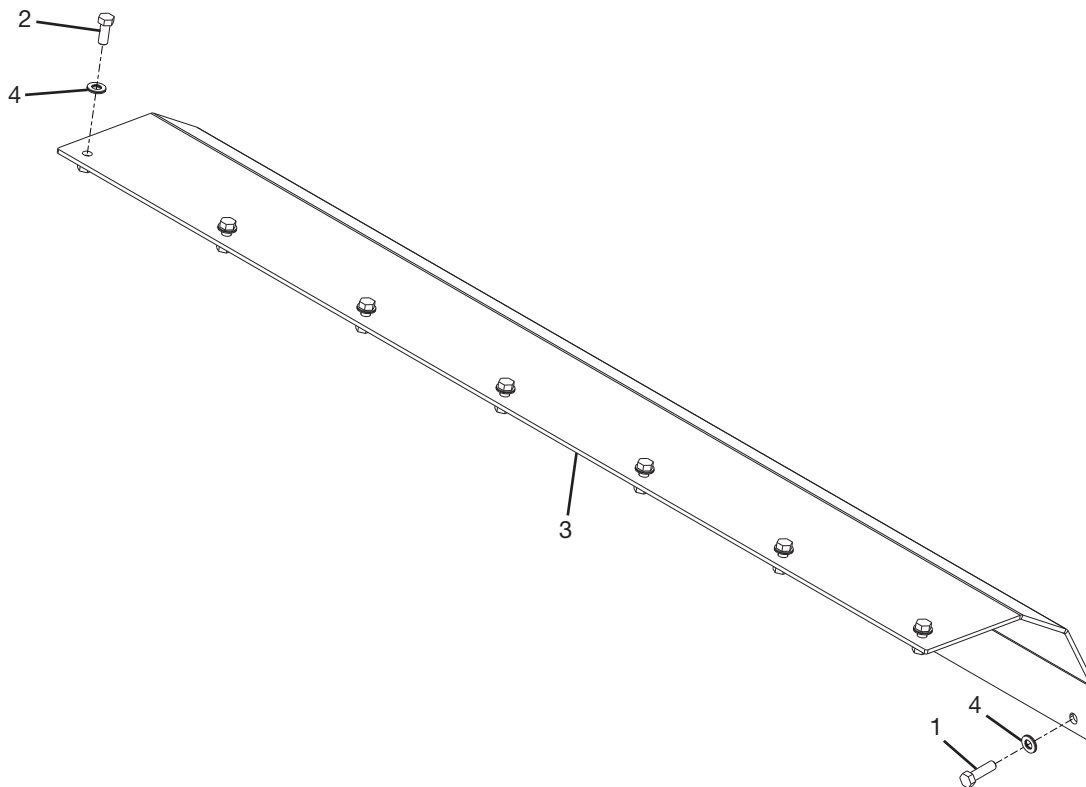

#	QTY.	PART #	DESCRIPTION
1	7	4245	BOLT, 1/2" X 1-3/4" FN TD GRADE 8 (61")
	8	4245	BOLT, 1/2" X 1-3/4" FN TD GRADE 8 (71")
2	7	4535	BOLT, 1/2-20 X 1-1/4 GR 8 (61")
	8	4535	BOLT, 1/2-20 X 1-1/4 GR 8 (71")
3	1	209040	LINER, BSL BOLT-IN 61
	1	209042	LINER, BSL BOLT-IN 71
4	14	N37780	WASHER, NORD-LOCK 1/2" SP (61")
	16	N37780	WASHER, NORD-LOCK 1/2" SP (71")



Specifications

DESCRIPTION	BATTLE AX SKID LOADER
Cutting Width	61 in. (154.9 cm)
	71 in. (180.3 cm)
Operating Capacity	6 in. (15.2 cm) Continuous
	10 in. (25.4 cm) Intermittent
Capacity Monitor	Pressure Gauge
Motor	Variable Displacement or High Pressure Gear
Rotor Bearing	2.1875 in. Piloted Double Taper
Rotor Tip Diameter	17 in. (43.2 cm)
Sprockets	Taperlock
Belt	14 mm x 20 Synchronous
	14 mm x 37 Synchronous
Mount	Universal Skid Type
Shear Bar	Adjustable
Pusher Bar	Adjustable Rigid Bar
Knives	Double Carbide Teeth
	Quadco Planer Teeth, Sharpenable (Optional)
	Quadco Planer Teeth Hardened (Optional)
Skid Shoes	Fixed - Replaceable
Deflector	Steel Chain
Anti-Wrap Protection	Bearing

Appendix

Dimensions

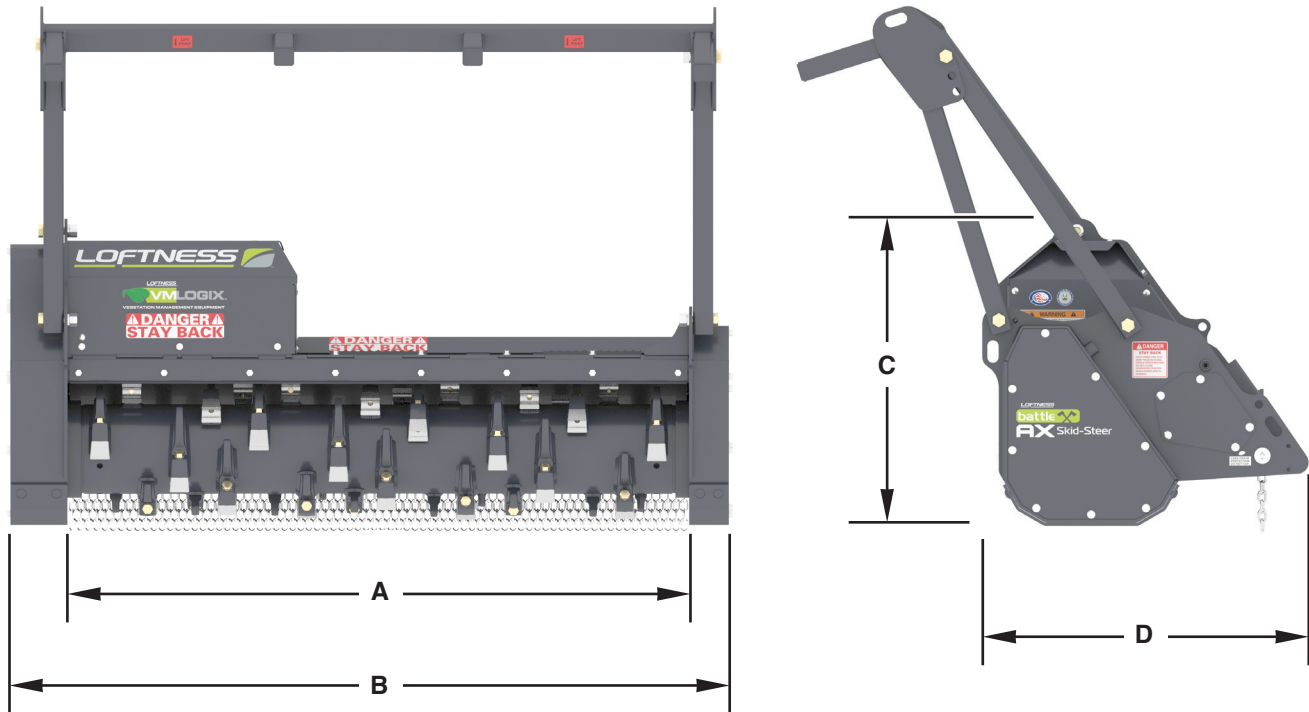

DESCRIPTION	BATTLE AX SKID LOADER	
	61	71
Cutting Width (A)	61 in. (155 cm)	71 in. (180.3 cm)
Overall Width (B)	79.1 in. (200.9 cm)	89.1 in. (226.3 cm)
Operating Height (C)	37.6 in. (95.5 cm)	37.6 in. (95.5 cm)
Overall Length (D)	40.0 in. (101.6 cm)	40.0 in. (101.6 cm)
Number Of Knives	30	36
Weight	2604 lb. (1181.2 kg)	2841 lb. (1288.7 kg)
Crated Weight	2831 lb. (1284.12 kg)	3088 lb. (1400.7 kg)

Torque Specifications

Inches Hardware and Lock Nuts

TORQUE CHARTS

Minimum Hardware Tightening Torques

Normal Assembly Applications
(Standard Hardware and Lock Nuts)

SAE Gr. 2 Nominal Size	SAE Grade 5		SAE Grade 8		LOCK NUTS			
	Unplated or Plated Silver	Plated W / ZnCr Gold	Unplated or Plated Silver	Plated W / ZnCr Gold	Unplated or Plated Silver	Plated W / ZnCr Gold	Grade W / Gr. 5 Bolt	Grade W / Gr. 8 Bolt
1/4	55 in.-lb. (6.2 N•m)	72 in.-lb. (8.1 N•m)	86 in.-lb. (9.7 N•m)	112 in.-lb. (12.6 N•m)	121 in.-lb. (13.6 N•m)	157 in.-lb. (17.7 N•m)	61 in.-lb. (6.9 N•m)	86 in.-lb. (9.8 N•m)
5/16	115 in.-lb. (13 N•m)	149 in.-lb. (17 N•m)	178 in.-lb. (20 N•m)	229 in.-lb. (26 N•m)	250 in.-lb. (28 N•m)	324 in.-lb. (37 N•m)	125 in.-lb. (14 N•m)	176 in.-lb. (20 N•m)
3/8	17 ft.-lb. (23 N•m)	22 ft.-lb. (30 N•m)	26 ft.-lb. (35 N•m)	34 ft.-lb. (46 N•m)	37 ft.-lb. (50 N•m)	48 ft.-lb. (65 N•m)	19 ft.-lb. (26 N•m)	26 ft.-lb. (35 N•m)
7/16	27 ft.-lb. (37 N•m)	35 ft.-lb. (47 N•m)	42 ft.-lb. (57 N•m)	54 ft.-lb. (73 N•m)	59 ft.-lb. (80 N•m)	77 ft.-lb. (104 N•m)	30 ft.-lb. (41 N•m)	42 ft.-lb. (57 N•m)
1/2	42 ft.-lb. (57 N•m)	54 ft.-lb. (73 N•m)	64 ft.-lb. (87 N•m)	83 ft.-lb. (113 N•m)	91 ft.-lb. (123 N•m)	117 ft.-lb. (159 N•m)	45 ft.-lb. (61 N•m)	64 ft.-lb. (88 N•m)
9/16	60 ft.-lb. (81 N•m)	77 ft.-lb. (104 N•m)	92 ft.-lb. (125 N•m)	120 ft.-lb. (163 N•m)	130 ft.-lb. (176 N•m)	169 ft.-lb. (229 N•m)	65 ft.-lb. (88 N•m)	92 ft.-lb. (125 N•m)
5/8	83 ft.-lb. (112 N•m)	107 ft.-lb. (145 N•m)	128 ft.-lb. (174 N•m)	165 ft.-lb. (224 N•m)	180 ft.-lb. (244 N•m)	233 ft.-lb. (316 N•m)	90 ft.-lb. (122 N•m)	127 ft.-lb. (172 N•m)
3/4	146 ft.-lb. (198 N•m)	189 ft.-lb. (256 N•m)	226 ft.-lb. (306 N•m)	293 ft.-lb. (397 N•m)	319 ft.-lb. (432 N•m)	413 ft.-lb. (560 N•m)	160 ft.-lb. (217 N•m)	226 ft.-lb. (306 N•m)
7/8	142 ft.-lb. (193 N•m)	183 ft.-lb. (248 N•m)	365 ft.-lb. (495 N•m)	473 ft.-lb. (641 N•m)	515 ft.-lb. (698 N•m)	667 ft.-lb. (904 N•m)	258 ft.-lb. (350 N•m)	364 ft.-lb. (494 N•m)
1	213 ft.-lb. (289 N•m)	275 ft.-lb. (373 N•m)	547 ft.-lb. (742 N•m)	708 ft.-lb. (960 N•m)	773 ft.-lb. (1048 N•m)	1000 ft.-lb. (1356 N•m)	386 ft.-lb. (523 N•m)	545 ft.-lb. (739 N•m)

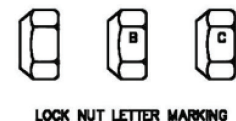
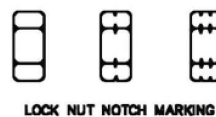
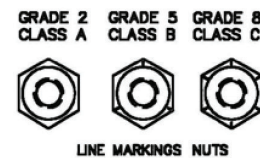
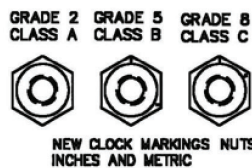
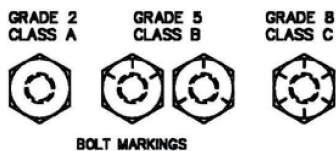

Appendix

Torque Specifications (Cont'd)

Metric Hardware and Lock Nuts

TORQUE CHARTS Minimum Hardware Tightening Torques

Normal Assembly Applications
(Metric Hardware and Lock Nuts)

Nominal Size	Class 5,8		Class 8,8		Class 10,9		Lock nuts Class 8 W / CL. 8,8 Bolt
	Unplated or Plated Silver	Plated W / ZnCr Gold	Unplated or Plated Silver	Plated W / ZnCr Gold	Unplated or Plated Silver	Plated W / ZnCr Gold	
M4	1.7 N•m (15 in.-lb.)	2.2 N•m (19 in.-lb.)	2.6 N•m (23 in.-lb.)	3.4 N•m (30 in.-lb.)	3.7 N•m (33 in.-lb.)	4.8 N•m (42 in.-lb.)	1.8 N•m (16 in.-lb.)
M6	5.8 N•m (51 in.-lb.)	7.6 N•m (67 in.-lb.)	8.9 N•m (79 in.-lb.)	12 N•m (102 in.-lb.)	13 N•m (115 in.-lb.)	17 N•m (150 in.-lb.)	6.3 N•m (56 in.-lb.)
M8	14 N•m (124 in.-lb.)	18 N•m (159 in.-lb.)	22 N•m (195 in.-lb.)	28 N•m (248 in.-lb.)	31 N•m (274 in.-lb.)	40 N•m (354 in.-lb.)	15 N•m (133 in.-lb.)
M10	28 N•m (21 ft.-lb.)	36 N•m (27 ft.-lb.)	43 N•m (32 ft.-lb.)	56 N•m (41 ft.-lb.)	61 N•m (45 ft.-lb.)	79 N•m (58 ft.-lb.)	30 N•m (22 ft.-lb.)
M12	49 N•m (36 ft.-lb.)	63 N•m (46 ft.-lb.)	75 N•m (55 ft.-lb.)	97 N•m (72 ft.-lb.)	107 N•m (79 ft.-lb.)	138 N•m (102 ft.-lb.)	53 N•m (39 ft.-lb.)
M16	121 N•m (89 ft.-lb.)	158 N•m (117 ft.-lb.)	186 N•m (137 ft.-lb.)	240 N•m (177 ft.-lb.)	266 N•m (196 ft.-lb.)	344 N•m (254 ft.-lb.)	131 N•m (97 ft.-lb.)
M20	237 N•m (175 ft.-lb.)	307 N•m (226 ft.-lb.)	375 N•m (277 ft.-lb.)	485 N•m (358 ft.-lb.)	519 N•m (383 ft.-lb.)	671 N•m (495 ft.-lb.)	265 N•m (195 ft.-lb.)
M24	411 N•m (303 ft.-lb.)	531 N•m (392 ft.-lb.)	648 N•m (478 ft.-lb.)	839 N•m (619 ft.-lb.)	897 N•m (662 ft.-lb.)	1160 N•m (855 ft.-lb.)	458 N•m (338 ft.-lb.)

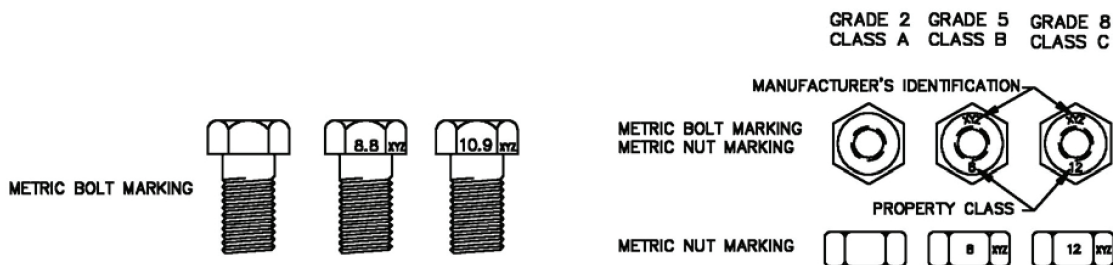



www.loftness.com

Loftness Specialized Equipment, Inc.
650 So. Main Street • PO Box 337 • Hector, MN 55342
Tel: 320.848.6266 • Fax: 320.848.6269 • Toll Free: 1.800.828.7624

Printed in USA
© Loftness 2025